

TB 9-2320-279-13&P-2

TECHNICAL BULLETIN

**OPERATOR'S, UNIT AND DIRECT SUPPORT
MAINTENANCE MANUAL, INSTALLATION INSTRUCTIONS, AND
REPAIR PARTS AND SPECIAL TOOLS LISTS (RPSTL)**

FOR

CREW PROTECTION KIT

FOR

**M977 SERIES, 8 X 8
HEAVY EXPANDED MOBILITY TACTICAL TRUCKS (HEMTT)**



DISTRIBUTION STATEMENT A - Approved for public release; distribution is unlimited.

HEADQUARTERS, DEPARTMENT OF THE ARMY

SEPTEMBER 2005

TECHNICAL BULLETIN
TB 9-2320-279-13&P-2
Change No. 1

HEADQUARTERS
DEPARTMENT OF THE ARMY
Washington, D.C., 31 JANUARY 2007

TECHNICAL BULLETIN

OPERATOR'S, UNIT AND DIRECT SUPPORT
MAINTENANCE MANUAL, INSTALLATION INSTRUCTIONS, AND
REPAIR PARTS AND SPECIAL TOOLS LISTS (RPSTL)

FOR

CREW PROTECTION KIT

FOR

M977 SERIES, 8 X 8
HEAVY EXPANDED MOBILITY TACTICAL TRUCKS (HEMTT)

TB 9-2320-279-13&P-2, dated 30 September 2005, is updated as follows:

1. File this change sheet in front of the publication for reference purposes.
2. New or changed material is indicated by a vertical bar adjacent to the material and/or change designations at the bottom of the affected page.
3. Remove old pages and insert new pages:

Remove Pages

A/(B Blank)
i thru iii/(iv Blank)
Index-1 thru Index-3/(Index-4 Blank)

Insert Pages

A/(B Blank)
i thru iii/(iv Blank)
Index-1 thru Index-4

4. Replace the following work packages with their revised version:

Work Package Number

WP 0002 00
WP 0004 00
WP 0008 00
WP 0034 00
WP 0038 00

5. Add the following new work packages:

Work Package Number

WP 0012 01

WP 0013 01

WP 0014 01

WP 0015 01

WP 0016 01

WP 0031 01

WP 0039 01

By Order of the Secretary of the Army:

PETER J. SCHOOMAKER
General, United States Army
Chief of Staff

Official:



JOYCE E. MORROW

Administrative Assistant to the
Secretary of the Army

0617202

DISTRIBUTION: To be distributed in accordance with the initial distribution requirements for IDN: 344822, requirements for TB 9-2320-279-13&P-2.

WARNING SUMMARY

This warning summary contains general safety warnings and hazardous materials warnings that must be understood and applied during operation and maintenance of this equipment. Failure to observe these precautions may cause serious injury or death to personnel. Also included are explanations of safety and hazardous materials icons used within this technical bulletin.



CHEMICAL - drops of liquid on hand shows that the material will cause burns or irritation to human skin or tissue.



EYE PROTECTION - person with goggles shows that the material will injure the eyes.



FIRE - flame shows that a material may ignite and cause burns.

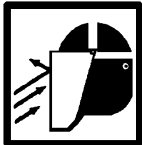

FLYING PARTICLES - arrows bouncing off face with face shield shows that particles flying through the air will harm face.



HEAVY PARTS - Hand with heavy object on top shows that heavy parts can crush and harm.



HEAVY PARTS - heavy object on human figure shows that heavy parts present a danger to life or limb.



VAPOR - human figure in a cloud shows that material vapors present a danger to life or health.

NOTE

For information on first aid, refer to FM 4-25.11.



WARNING

ADHESIVES AND SEALANTS

Use caution when using adhesives and sealants. Prolonged inhalation of vapors can cause lung irritation. Contact with skin can cause dermatitis. Wear gloves and safety goggles and use product in a well-ventilated area away from open flame. If ingested, keep individual calm and seek medical attention. DO NOT induce vomiting. If contact with skin or eyes is made, flush thoroughly with water. Dispose of cleanup rags IAW local policy and ordinances. Failure to follow this warning may cause injury to personnel.



WARNING

COMPRESSED AIR

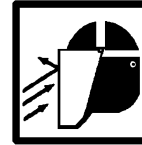

Particles blown by compressed air are hazardous. DO NOT exceed 15 psi (103 kPa) nozzle pressure when drying parts with compressed air. Use a maximum of 30 psi (207 kPa) when cleaning components. DO NOT direct compressed air against human skin. Failure to follow this warning may result in injury or death to personnel. Make sure air stream is directed away from user and other personnel in the area. To prevent injury, user must wear protective goggles or face shield.



WARNING

DRILLING AND RIVETING

Eye protection is required when drilling and when using riveter to install rivets. Failure to follow this warning may cause injury to personnel.



WARNING

HEAVY COMPONENTS



Use caution when handling heavy parts. Provide adequate support and use assistance during procedure. Ensure that any lifting device used is in good condition and of suitable load capacity. Keep clear of heavy parts supported only by lifting device. Failure to follow this warning may cause injury or death to personnel.

WARNING

HEMTT OPERATION

- Due to increased weight of HEMTT with armor kit installed, operator should be aware of differences in vehicle's driving characteristics and adjust his/her driving accordingly. Failure to follow this warning may cause an accident and injury or death to personnel.
- Due to increased weight of doors, use extreme caution when opening and closing doors. If vehicle is parked on non-level ground, door may swing in direction of slope. Failure to follow this warning may cause injury to personnel.
- When placing foot on step to enter cab of vehicle, be aware of side blast deflector. Edge of side blast deflector protrudes outward beyond step. Failure to follow this warning may cause injury to personnel.

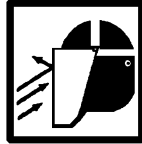

WARNING

SHARP EDGES

- Use caution when handling window glass. Glass can break unexpectedly during removal/installation procedure. Wear face shield, apron, and gloves. Failure to follow this warning may cause injury to personnel.
- Edges of metal armor panels may be sharp. Wear protective gloves when handling armor panels. Failure to follow this warning may cause injury to personnel.



WARNING

SOLVENT CLEANING COMPOUND



- Solvent cleaning compound MIL-PRF-680 Type III is an environmentally compliant and low toxic material. However, it may be irritating to the eyes and skin. Use protective gloves and goggles. Use in well-ventilated areas. Keep away from open flames and other sources of ignition. Failure to follow this warning may result in injury or death to personnel.
- Improper cleaning methods and use of unauthorized cleaning solvents may injure personnel and damage equipment. Refer to TM 9-247, *Materials Used for Cleaning, Preserving, Abrading, and Cementing Ordnance Materiel and Related Materials Including Chemicals*, for correct information.
- Fire extinguishers should be placed nearby when using solvent cleaning compound. Failure to follow this warning may result in injury or death.
- Cloths or rags saturated with solvent cleaning compound must be disposed of IAW authorized facilities' procedures. Failure to follow this warning may result in injury.

WARNING

THREAT PROTECTION

For proper threat protection, ballistic glass must be correctly installed onto ballistic glass frame. During installation, ensure that decal "INSTALL THIS SURFACE TOWARDS THREAT" is located on outside of cab. Improperly installed ballistic glass will not protect occupants. Failure to follow this warning may cause injury or death.

WARNING

WELDING NOT AUTHORIZED

To ensure survivability of personnel, welding repairs on armor kit are NOT authorized. If armor plates are damaged, they must be replaced. Failure to follow this warning may cause failure of armor, resulting in injury or death to personnel.

LIST OF EFFECTIVE PAGES/WORK PACKAGES

Date of issue for original manual is:

Original 30 September 2005
 Change 1 31 January 2007

Total number of pages for front and rear matter is 22 and total number of work packages is 47 consisting of the following:

Page/WP No.	*Change No.	Page/WP No.	*Change No.
Cover/Blank	0	WP 0022 00	0
a to c/(d Blank)	0	WP 0023 00	0
A/(B Blank)	1	WP 0024 00	0
i to iii/(iv Blank)	1	WP 0025 00	0
v to vi	0	WP 0026 00	0
Ch. 1 title page	0	WP 0027 00	0
WP 0001 00	0	WP 0028 00	0
WP 0002 00	1	WP 0029 00	0
WP 0003 00	0	WP 0030 00	0
Ch. 2 title page	0	WP 0031 00	0
WP 0004 00	1	WP 0031 01	1
WP 0005 00	0	Ch. 5 title page	0
WP 0006 00	0	WP 0032 00	0
WP 0007 00	0	WP 0033 00	0
Ch. 3 title page	0	WP 0034 00	1
WP 0008 00	1	WP 0035 00	0
WP 0009 00	0	WP 0036 00	0
WP 0010 00	0	WP 0037 00	0
Ch. 4 title page	0	WP 0038 00	1
WP 0011 00	0	WP 0039 00	0
WP 0012 00	0	WP 0039 01	1
WP 0012 01	1	WP 0040 00	0
WP 0013 00	0	Index-1 thru Index-3/(Index-4 Blank)	1
WP 0013 01	1		
WP 0014 00	0		
WP 0014 01	1		
WP 0015 00	0		
WP 0015 01	1		
WP 0016 00	0		
WP 0016 01	1		
WP 0017 00	0		
WP 0018 00	0		
WP 0019 00	0		
WP 0020 00	0		
WP 0021 00	0		

* Zero in this column indicates an original page or work package.

A/(B Blank)

TECHNICAL BULLETIN
 TB 9-2320-279-13&P-2
 Change 1

HEADQUARTERS
 DEPARTMENT OF THE ARMY
 Washington, D.C., 30 September 2005

TECHNICAL BULLETIN

**OPERATOR’S, UNIT AND DIRECT SUPPORT
 MAINTENANCE MANUAL, INSTALLATION INSTRUCTIONS, AND
 REPAIR PARTS AND SPECIAL TOOLS LISTS (RPSTL)**

FOR

CREW PROTECTION KIT

FOR

**M977 SERIES, 8 X 8
 HEAVY EXPANDED MOBILITY TACTICAL TRUCKS (HEMTT)**

Current as of 28 July 2005

REPORTING ERRORS AND RECOMMENDING IMPROVEMENTS

You can help improve this publication. If you find any mistakes or if you know of a way to improve the procedures, please let us know. Submit your DA Form 2028 (*Recommended Changes to Equipment Technical Publications*), through the Internet, on the Army Electronic Product Support (AEPS) website. The Internet address is <https://aeeps.ria.army.mil/>. The DA Form 2028 is located under the Public Applications section in the AEPS Public Home Page. Fill out the form and click on SUBMIT. Using this form on the AEPS will enable us to respond quicker to your comments and better manage the DA Form 2028 program. You may also mail, fax or e-mail your letter or DA Form 2028 direct to: AMSTA-LC-LMIT/TECH PUBS, TACOM-RI, 1 Rock Island Arsenal, Rock Island, IL 61299-7630. The e-mail address is: ROCK-TACOM-TECH-PUBS@conus.army.mil. The fax number is DSN 793-0726 or Commercial (309) 782-0726.

Table of Contents

	Page Number
Warning Summary	a
How to Use This Technical Bulletin	v
CHAPTER 1 GENERAL INFORMATION, EQUIPMENT DESCRIPTION AND DATA, AND THEORY OF OPERATION	
WP 0001 00 General Information	0001 00-1
WP 0002 00 Equipment Description and Data	0002 00-1
WP 0003 00 Theory of Operation	0003 00-1
CHAPTER 2 OPERATOR INSTRUCTIONS	
WP 0004 00 Description and Use of Operator Controls	0004 00-1
WP 0005 00 Operation Under Usual Conditions	0005 00-1
WP 0006 00 Operation Under Unusual Conditions	0006 00-1
WP 0007 00 Stowage and Decal/Data Plate Guide	0007 00-1

DISTRIBUTION STATEMENT A: Approved for public release; distribution is unlimited.

Table of Contents - Continued

**Page
Number**

CHAPTER 3 OPERATOR MAINTENANCE INSTRUCTIONS

WP 0008 00	Operator Preventive Maintenance Checks and Services (PMCS) Introduction .	0008 00-1
WP 0009 00	Operator Preventive Maintenance Checks and Services (PMCS)	0009 00-1
WP 0010 00	Cleaning Ballistic Glass	0010 00-1

CHAPTER 4 UNIT MAINTENANCE INSTRUCTIONS

WP 0011 00	General Maintenance Instructions	0011 00-1
WP 0012 00	Door Handle Assembly Replacement	0012 00-1
WP 0012 01	Door Handle Assembly Replacement - Model B	0012 01-1
WP 0013 00	Door Latch and Lock Pin Replacement	0013 00-1
WP 0013 01	Door Latch and Combat Lock Replacement - Model B	0013 01-1
WP 0014 00	Door Ballistic Glass and Frame Assembly Replacement	0014 00-1
WP 0014 01	Door Ballistic Glass Replacement - Model B	0014 01-1
WP 0015 00	Door Assembly Replacement	0015 00-1
WP 0015 01	Door Assembly Replacement - Model B	0015 01-1
WP 0016 00	Door Latch Adjustment	0016 00-1
WP 0016 01	Door Latch Adjustment - Model B	0016 01-1
WP 0017 00	Windshield Ballistic Glass Replacement	0017 00-1
WP 0018 00	Upper Brush Guard Replacement	0018 00-1
WP 0019 00	Lower Brush Guard Replacement	0019 00-1
WP 0020 00	Louvered Grille Replacement	0020 00-1
WP 0021 00	Headlight and Composite Light Replacement	0021 00-1
WP 0022 00	Blackout Drive Light Replacement	0022 00-1
WP 0023 00	Escape Hatch Assembly Maintenance	0023 00-1
WP 0024 00	Roof Armor Replacement	0024 00-1
WP 0025 00	Rear Cab (Right) Armor Replacement	0025 00-1
WP 0026 00	Rear Cab (Left) Armor Replacement	0026 00-1
WP 0027 00	Right Side Blast Deflector Replacement	0027 00-1
WP 0028 00	Left Side Blast Deflector Replacement	0028 00-1
WP 0029 00	Center Blast Deflector Replacement	0029 00-1
WP 0030 00	Rear Side Armor Replacement	0030 00-1
WP 0031 00	Front Side Armor Assembly Replacement	0031 00-1
WP 0031 01	Side Armor Replacement - Model B	0031 01-1

CHAPTER 5 SUPPORTING INFORMATION

WP 0032 00	References	0032 00-1
WP 0033 00	Maintenance Allocation Chart (MAC) Introduction	0033 00-1
WP 0034 00	Maintenance Allocation Chart (MAC)	0034 00-1
WP 0035 00	Expendable and Durable Items List	0035 00-1
WP 0036 00	Torque Limits	0036 00-1
WP 0037 00	Field Maintenance (Unit and Direct Support Maintenance) Repair Parts Lists (RPSTL) Introduction	0037 00-1

Table of Contents - Continued

	Page Number
WP 0038 00 Field Maintenance (Unit and Direct Support Maintenance) Repair Parts Lists (RPSTL)	0038 00-1
WP 0039 00 Crew Protection Kit Installation Instructions	0039 00-1
WP 0039 01 Gen IIIB Installation Instructions	0039 01-1
WP 0040 00 C4ISR Instructions	0040 00-1
 GROUP 33SPECIAL PURPOSE KITS	
3307 - SPECIAL PURPOSE KITS.....	1-1
UNDERBODY ARMOR PROTECTION KIT	1 1-1
WINDSHIELD ARMOR PROTECTION KIT	2 2-1
REAR CAB ARMOR PROTECTION KIT	3 3-1
SIDE ARMOR KIT, LEFT AND RIGHT SIDES	4 4-1
ARMORED DOOR ASSEMBLY, LEFT AND RIGHT SIDES	5 5-1
SIDE ARMOR DOOR, LEFT AND RIGHT SIDE - MODEL B.....	5A 5A-1
ARMOR DOOR ASSEMBLY - MODEL B.....	5B 5B-1
ROOF ARMOR PROTECTION KIT	6 6-1
FRONT ARMOR PROTECTION KIT.....	7 7-1
 GROUP 94REPAIR KITS	
94-1 - REPAIR KITS	KITS-1
REPAIR KITS	KITS KITS-1
 NATIONAL STOCK NUMBER INDEX.....	 I-1
PART NUMBER INDEX	I-4

HOW TO USE THIS TECHNICAL BULLETIN

NOTE

If at any time you are unsure how to use this technical bulletin or you cannot locate the information you need, notify your supervisor.

INTRODUCTION

1. This technical bulletin is designed to help you operate and maintain the HEMTT Crew Protection Kit. It also provides installation instructions for the armor kit and includes the Repair Parts and Special Tools List (RPSTL).
2. This technical bulletin is written in work package format:
 - a. Chapters divide the technical bulletin into major categories of information (e.g., *General Information, Equipment Description and Data, and Theory of Operation; Operator Instructions; Operator Maintenance Instructions; Unit Maintenance Instructions; and Supporting Information*).
 - b. Each Chapter is divided into work packages, which are identified by a 6-digit number (e.g. 0001 00, 0002 00, etc.) located on the upper right-hand corner of each page. The work package page number (e.g. 0001 00-1, 0001 00-2, etc.) is located centered at the bottom of each page.
 - c. If a Change Package is issued to this technical bulletin, added work packages use the 5th and 6th digits of their number to indicate new material. For instance, work packages inserted between WP 0001 00 and WP 0002 00 are numbered WP 0001 01, WP 0001 02, etc.
3. Read through this technical bulletin to become familiar with its organization and contents before attempting to operate or maintain the armor kit.

CONTENTS OF THIS TECHNICAL BULLETIN

1. A *Warning Summary* is located at the beginning of this technical bulletin. Become familiar with these warnings before operating or performing maintenance on the armor kit.
2. A *Table of Contents*, located in the front of the technical bulletin, lists all chapters and work packages in the publication.
 - a. The Table of Contents also provides *Reporting Errors and Recommending Improvements* information and DA Form 2028 addresses, for the submittal of corrections to this technical bulletin.
 - b. If you cannot find what you are looking for in the Table of Contents, refer to the alphabetical *Index* at the back of the technical bulletin.
3. Chapter 1, *General Information, Equipment Description, and Theory of Operation*, provides general information on the technical bulletin and the armor kit.
4. Chapter 2, *Operator Instructions*, explains and illustrates all operator procedures for the armor kit: *Operation Under Usual Conditions* and *Operation Under Unusual Conditions*.
5. Chapter 3, *Operator Maintenance Instructions*, includes *Operator Preventive Maintenance Checks and Services (PMCS) Introduction* and *Operator Preventive Maintenance Checks and Services (PMCS)*.
6. Chapter 4, *Unit Maintenance Instructions* includes all unit maintenance tasks.
7. Chapter 5, *Supporting Information*, includes *References; Maintenance Allocation Chart (MAC) Introduction; Maintenance Allocation Chart (MAC); Expendable and Durable Items List; Torque Limits; Crew Protection Kit Installation Instructions; Repair Parts and Special Tools List (RPSTL) Introduction; and Repair Parts and Special Tools List (RPSTL)*.

FEATURES OF THIS TECHNICAL BULLETIN

1. WARNINGS, CAUTIONS, NOTES, subject headings, and other important information are highlighted in **BOLD** print as a visual aid.

WARNING

A WARNING indicates a hazard which may cause injury or death to personnel.

CAUTION

A CAUTION is a reminder of safety practices or directs attention to usage practices that may cause damage to equipment.

NOTE

A NOTE is a statement containing information that will make the procedures easier to perform.

2. Statements and words of particular interest may be printed in CAPITAL LETTERS to create emphasis.
3. Within a procedural step, reference may be made to another work package in this technical bulletin or to another manual. These references indicate where you should look for more complete information.
 - a. If you are told: "Refer to *Crew Protection Kit Installation Instructions* (WP 0039 00)," go to WP 0039 00 in this technical bulletin for instructions on this procedure.
 - b. If you are told: "For complete information on HEMTT Operator PMCS, refer to TM 9-2320-279-10," go to *References* in WP 0032 00 for complete information on the cited reference.
4. Illustrations are placed after, and as close to, the procedural steps to which they apply. Callouts placed on the art are text or numbers.
5. Numbers located at lower right corner of art (e.g. 417-001, 417-002, 440-001, 440-002, etc.) are art control numbers and are used for tracking purposes only.
6. Technical instructions include metric units as well as standard units. For your reference, a *Metric Conversion Chart* is located on the inside back cover of the technical bulletin.

CHAPTER 1
GENERAL INFORMATION, EQUIPMENT
DESCRIPTION AND DATA, AND THEORY OF OPERATION

SCOPE

This technical bulletin is for your use in operating and performing Operator, Unit, and Direct Support (Field) Maintenance on the Crew Protection Kit installed on the M977 Series, 8 X 8, Heavy Expanded Mobility Tactical Trucks (HEMTT). This technical bulletin also covers armor kit installation instructions and the Repair Parts and Special Tools List (RPSTL).

MAINTENANCE FORMS, RECORDS, AND REPORTS

Department of the Army forms and procedures used for the equipment will be those prescribed by DA PAM 750-8, *The Army Maintenance Management System (TAMMS) Users Manual*, as contained in the Maintenance Management Update.

REPORTING EQUIPMENT IMPROVEMENT RECOMMENDATIONS (EIR)

If your armor kit needs improvement, let us know. Send us an EIR. You, the user, are the only one who can tell us what you don't like about your equipment. Let us know why you don't like the design or performance. If you have Internet access, the easiest and fastest way to report problems or suggestions is to go to <https://aeps.ria.army.mil/aepspublic.cfm> (scroll down and choose the "Submit Quality Deficiency Report" bar). The Internet form lets you choose to submit an Equipment Improvement Recommendation (EIR), or a Product Quality Deficiency Report (PQDR). You may also submit your information using an SF Form 368 (*Product Quality Deficiency Report*). You can send your SF Form 368 via e-mail, regular mail, or facsimile using the addresses/facsimile numbers specified in DA PAM 750-8, *The Army Maintenance Management System (TAMMS) Users Manual*. We will send you a reply.

CORROSION PREVENTION AND CONTROL (CPC)

1. Corrosion Prevention and Control (CPC) of Army materiel is a continuing concern. It is important that any corrosion problems with this item be reported so that the problem can be corrected and improvements can be made to prevent the problem in future items.
2. While corrosion is typically associated with rusting of metals, it can also include deterioration of other materials, such as rubber and plastic. Unusual cracking, softening, swelling, or breaking of these materials may be a corrosion problem. If a corrosion problem is identified, it can be reported using SF Form 368 (*Product Quality Deficiency Report*). Use of key words such as "corrosion," "rust," "deterioration," or "cracking" will ensure that the information is identified as a CPC problem. The form should be submitted to the address specified in DA PAM 750-8.

DESTRUCTION OF ARMY MATERIEL TO PREVENT ENEMY USE

For destruction of Army material to prevent enemy use, refer to TM 750-244-6.

PREPARATION FOR STORAGE OR SHIPMENT

Refer to TM 9-2320-279-20 for preparation for storage or shipment.

LIST OF ABBREVIATIONS/ACRONYMS

NOTE

Refer to ASME Y14.38-1999 for standard abbreviations.

ABBREVIATION/ACRONYMS	DEFINITION
cm	Centimeter
EPLRS	Enhanced Position Location Reporting System
GPS	Global Positioning System
HEMTT	Heavy Expanded Mobility Tactical Truck
IAW	In Accordance With
IED	Improvised Explosive Device
kg	Kilogram
lb-ft	Pound Foot
lb-in.	Pound Inch
mm	Millimeter
Nm	Newton Meter
PLGR	Precision Lightweight GPS Receiver
PMCS	Preventive Maintenance Checks and Services
P/N	Part Number
SINCGARS	Single Channel Ground and Airborne Radio System

QUALITY OF MATERIAL

Material used for replacement, repair or modification of the Crew Protection Kit must meet the requirements of this technical bulletin. If quality of material requirements are not stated in this technical bulletin, the material must meet the requirements of the drawings, standards, specifications, or approved engineering change proposals applicable to the Crew Protection Kit.

SAFETY, CARE, AND HANDLING

No procedures are required.

END OF WORK PACKAGE

EQUIPMENT DESCRIPTION AND DATA

0002 00***EQUIPMENT CHARACTERISTICS, CAPABILITIES, AND FEATURES***

1. The Crew Protection Kit provides the M977 Series, 8 X 8, Heavy Expanded Mobility Tactical Truck (HEMTT) with improved protection.
2. The Crew Protection Kit consists of armor panels that are installed on the cab of the HEMTT.
3. The Crew Protection Kit consists of the following:
 - a. Driver-side, center, and passenger-side blast deflectors under the vehicle
 - b. Front, side, rear, and roof armor panels
 - c. Door assemblies
 - d. Radiator grille armor
 - e. Ballistic glass for windshield and side door windows
4. The Crew Protection Kit for the M977 Series, 8 X 8, Heavy Expanded Mobility Tactical Truck (HEMTT) has two different side armor and door armor configurations. The updated side armor and door armor are referred to as MODEL B within this manual.

LOCATION AND DESCRIPTION OF MAJOR COMPONENTS

The illustration below shows major armor kit components and their location in relation to the HEMTT cab.

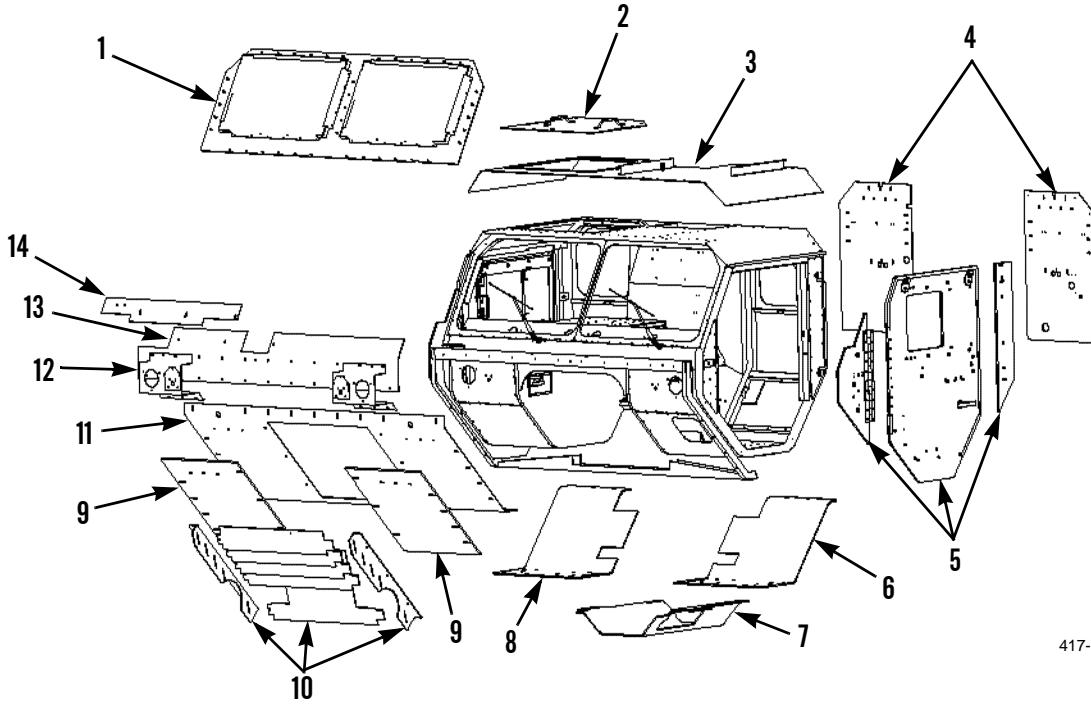

417-002

KEY	COMPONENT
1	Windshield Frame and Windshield
2	Escape Hatch (Part of Roof Armor)
3	Roof Armor
4	Rear Cab Armor
5	Cab Side Armor (Includes Door Assembly)
6	Driver-Side Blast Deflector
7	Center Blast Deflector
8	Passenger-Side Blast Deflector
9	Brush Guard Armor Panel
10	Louvered Grille Assembly
11	Lower Brush Guard
12	Headlight Armor
13	Upper Brush Guard
14	Upper Brush Guard Cover

LOCATION AND DESCRIPTION OF MAJOR COMPONENTS - CONTINUED

Model B

The illustration below shows updated armor kit components (Model B) and their location.

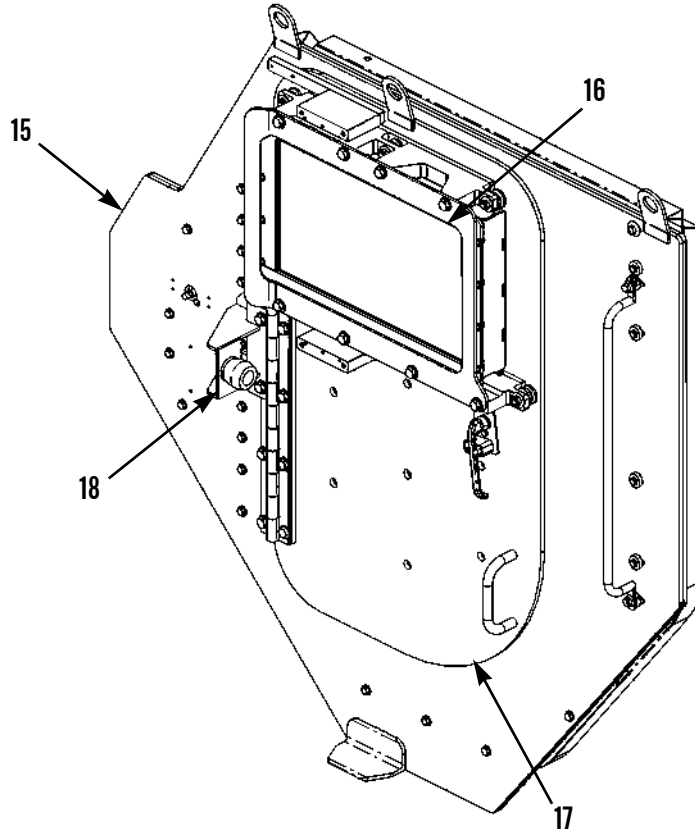

417-059

KEY	COMPONENT
15	Side Armor Assembly
16	Door Ballistic Glass
17	Door Armor Assembly
18	Door Stop

EQUIPMENT DESCRIPTION AND DATA - CONTINUED

0002 00

EQUIPMENT DATA

1. Many components of the Crew Protection Kit are heavier than allowable for one or two persons to lift. To ensure personnel safety during maintenance of the armor kit, it is important to be aware of component weights.
2. Table 1 lists components of the armor kit, their weight, quantity per vehicle, and total armor kit weight per vehicle.
3. Table 2 lists Model B components of the updated armor kit, their weight, quantity per vehicle, and total armor kit weight per vehicle.
4. Table 3 lists components that are removed from the vehicle, their weight, quantity per vehicle, and total weight per vehicle.

Table 1. Crew Protection Kit Components.

COMPONENT DESCRIPTION	WEIGHT OF COMPONENT	QUANTITY PER VEHICLE	TOTAL WEIGHT PER VEHICLE
Windshield Frame	123.00 lb (55.79 kg)	1	123.00 lb (55.79 kg)
Windshield Ballistic Glass	112.87 lb (51.20 kg)	2	225.74 lb (102.39 kg)
Upper Brush Guard	131.00 lb (59.42 kg)	1	131.00 lb (59.42 kg)
Lower Brush Guard	219.00 lb (99.34 kg)	1	219.00 lb (99.34 kg)
Louvered Grille Assembly	149.00 lb (67.59 kg)	1 (Set)	149.00 lb (67.59 kg)
Roof Escape Hatch	61.00 lb (27.67 kg)	1	61.00 lb (27.67 kg)
Front Side Panels	31.00 lb (14.06 kg)	2	62.00 lb (28.12 kg)
Door Assemblies	336.40 lb (152.59 kg)	2	672.80 lb (305.18 kg)
Roof Armor	166.00 lb (75.30 kg)	1	166.00 lb (75.30 kg)
Rear Cab Armor	100.20 lb (45.45 kg)	2	200.40 lb (90.90 kg)
Driver-Side Blast Deflector	145.00 lb (65.77 kg)	1	145.00 lb (65.77 kg)
Passenger-Side Blast Deflector	145.00 lb (65.77 kg)	1	145.00 lb (65.77 kg)
Center Blast Deflector	147.00 lb (66.68 kg)	1	147.00 lb (66.68 kg)
Cab Rear Side Armor	27.00 lb (12.25 kg)	2	54.00 lb (24.49 kg)
Brush Guard Shim	6.55 lb (2.97 kg)	1	6.55 lb (2.97 kg)
Headlight Brackets	12.60 lb (5.72 kg)	2	25.20 lb (11.43 kg)
Upper Brush Guard Cover	26.50 lb (12.02 kg)	1	26.50 lb (12.02 kg)
Brackets, Mounts, Hardware	225.00 lb (102.06 kg)	1 Lot	225.00 lb (102.06 kg)
Lower Brush Guard Panel Applique	49.90 lb (22.63 kg)	2	99.80 lb (45.27 kg)
TOTAL WEIGHT OF CREW PROTECTION KIT			2,883.99 lb (1308.16 kg)

EQUIPMENT DATA - CONTINUED

Table 2. Crew Protection Kit Components - Model B.

COMPONENT DESCRIPTION	WEIGHT OF COMPONENT	QUANTITY PER VEHICLE	TOTAL WEIGHT PER VEHICLE
Windshield Frame	123.00 lb (55.79 kg)	1	123.00 lb (55.79 kg)
Windshield Ballistic Glass	112.87 lb (51.20 kg)	2	225.74 lb (102.39 kg)
Upper Brush Guard	131.00 lb (59.42 kg)	1	131.00 lb (59.42 kg)
Lower Brush Guard	219.00 lb (99.34 kg)	1	219.00 lb (99.34 kg)
Louvered Grille Assembly	149.00 lb (67.59 kg)	1 (Set)	149.00 lb (67.59 kg)
Roof Escape Hatch	61.00 lb (27.67 kg)	1	61.00 lb (27.67 kg)
Side Panels - Model B	360.00 lb (163.29 kg)	2	720.00 lb (326.59 kg)
Door Assemblies - Model B	357.00 lb (161.93 kg)	2	714.00 lb (323.87 kg)
Roof Armor	166.00 lb (75.30 kg)	1	166.00 lb (75.30 kg)
Rear Cab Armor	100.20 lb (45.45 kg)	2	200.40 lb (90.90 kg)
Driver-Side Blast Deflector	145.00 lb (65.77 kg)	1	145.00 lb (65.77 kg)
Passenger-Side Blast Deflector	145.00 lb (65.77 kg)	1	145.00 lb (65.77 kg)
Center Blast Deflector	147.00 lb (66.68 kg)	1	147.00 lb (66.68 kg)
Brush Guard Shim	6.55 lb (2.97 kg)	1	6.55 lb (2.97 kg)
Headlight Brackets	12.60 lb (5.72 kg)	2	25.20 lb (11.43 kg)
Upper Brush Guard Cover	26.50 lb (12.02 kg)	1	26.50 lb (12.02 kg)
Brackets, Mounts, Hardware	225.00 lb (102.06 kg)	1 Lot	225.00 lb (102.06 kg)
Lower Brush Guard Panel Applique	49.90 lb (22.63 kg)	2	99.80 lb (45.27 kg)
TOTAL WEIGHT OF CREW PROTECTION KIT MODEL B			3,529.19 lb (1,600.81 kg)

EQUIPMENT DATA - CONTINUED

Table 3. Components Removed from Vehicle.

COMPONENT DESCRIPTION	WEIGHT OF COMPONENT	QUANTITY PER VEHICLE	TOTAL WEIGHT PER VEHICLE
Doors	100.00 lb (45.4 kg)	2	200.00 lb (90.70 kg)
Brush Guard	112.00 lb (50.8 kg)	1	112.00 lb (50.8 kg)
Rear Windows	8.50 lb (3.9 kg)	2	17.00 lb (7.7 kg)
Windshield (each)	32.10 lb (14.6 kg)	2	64.20 lb (29.1 kg)
Total Weight Removed			393.20 lb (178.4 kg)
TOTAL WEIGHT INCREASE TO VEHICLE			2,490.79 lb (1129.80 kg)
TOTAL WEIGHT INCREASE TO VEHICLE, MODEL B			3,135.99 lb (1,422.46 kg)

END OF WORK PACKAGE

GENERAL

The Heavy Expanded Mobility Tactical Trucks (HEMTT) Crew Protection Kit consists of two armored doors, roof armor, windshield ballistic glass, three blast deflectors, one upper and one lower brush guard, forward and rear side armor panels, rear cab armor panels, an armored louvered grille assembly, and an armored escape hatch.

The Door Armor Attachment Assembly consists of an armor panel bracket that is mounted to the existing door frame and is bolted in place of the existing door's hinge. The armored door assembly (which incorporates sliding ballistic glass) is bolted to the hinge assembly on the armor panel. The roof armor panel is installed using the existing bolt hole pattern (used for the machine gun mount) on the roof on the passenger side and the mounting brackets (front and rear) on the driver's side. The roof armor is a one-piece panel that requires material handling equipment (hoist, forklift, etc.) for installation due to its weight.

The remaining armor panels are fastened to the vehicle using attachment brackets and hardware. If the vehicle is equipped with, or will be equipped with, C4ISR gear, use the Installation Instructions contained in WP 040 00.

END OF WORK PACKAGE

CHAPTER 2
OPERATOR INSTRUCTIONS

DESCRIPTION AND USE OF OPERATOR CONTROLS

0004 00

GENERAL

1. This work package describes all operator controls for the Crew Protection Kit.
2. Do not attempt to operate the HEMTT with Crew Protection Kit installed until becoming familiar with the location and function of all armor kit controls.

OPERATOR CONTROLS

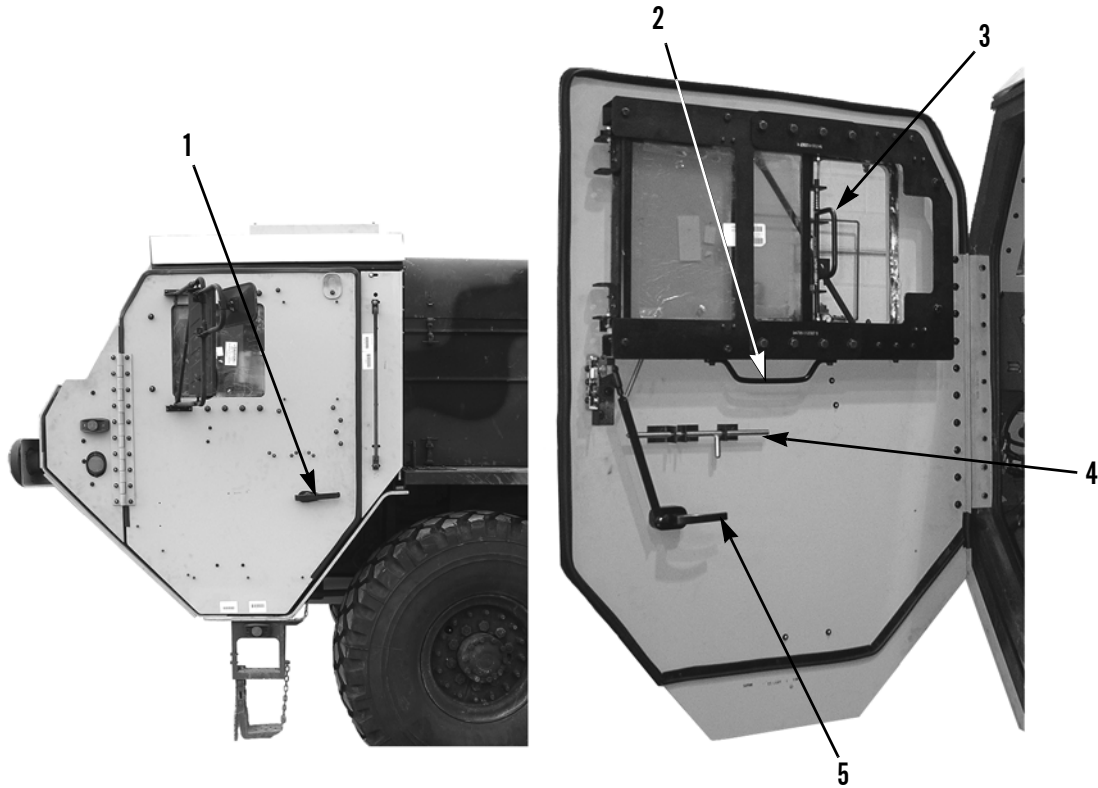

417-061

KEY	CONTROL OR INDICATOR	FUNCTION
1	Exterior Door Handle	Allows driver or passenger-side door to be opened from the outside.
2	Interior Door Grab Handle	Provides hand hold for opening or closing door.
3	Window Opening Handle	Lift up on handle and slide window to the rear to open window.
4	Lock Pin	Slide rod rearward to lock side door. Slide rod forward to unlock side door.
5	Interior Door Handle	Allows driver- or passenger-side door to be opened from the inside.

OPERATOR CONTROLS - CONTINUED

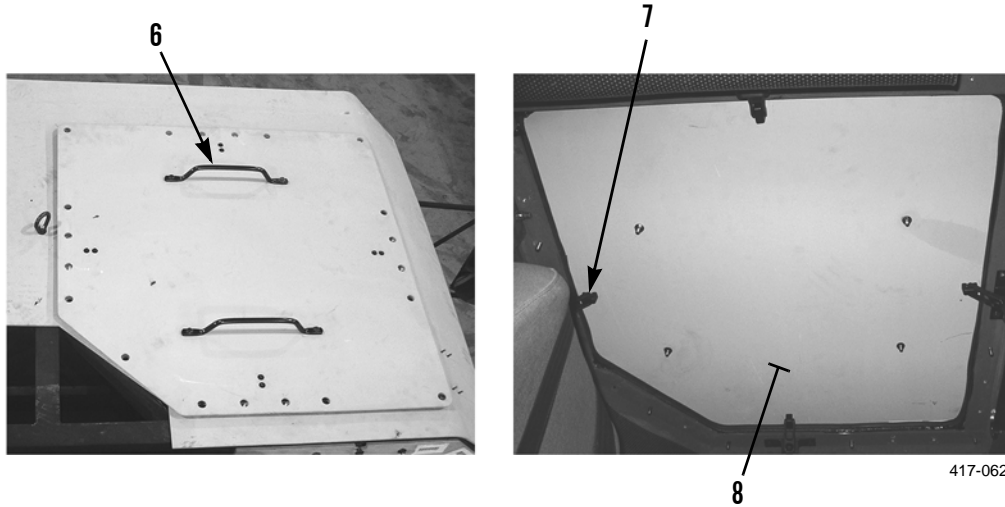

KEY	CONTROL OR INDICATOR	FUNCTION
6	Grab Handle	Use two grab handles to install escape hatch from the outside.
7	Draw Latch T-handle	In an emergency, pull on T-handle to unlatch each of four latches, then push out on escape hatch to exit vehicle through roof.
8	Escape Hatch	Provides alternate exit path through roof.

OPERATOR CONTROLS - MODEL B

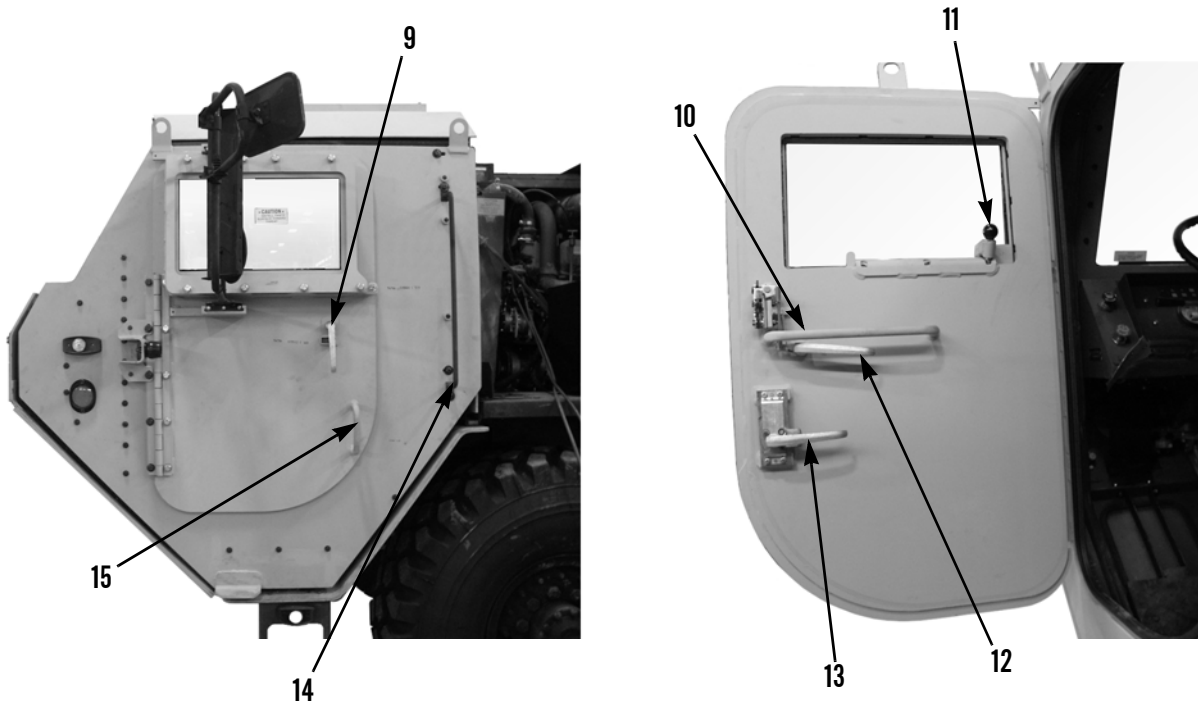

440-060

KEY	CONTROL OR INDICATOR	FUNCTION
9	Exterior Door Handle	Allows driver- or passenger-side door to be opened from the outside.
10	Interior Door Grab Handle	Provides hand hold for opening or closing door.
11	Window Opening Knob	Pull up on knob and slide window to the rear to open window.
12	Interior Door Handle	Allows driver- or passenger-side door to be opened from the inside.
13	Combat Lock Handle	Rotate handle upward to lock door. Rotate handle downward to unlock door.
14	Grab Handle	Provides a hand hold.
15	Door Grab Handle	Provides a hand hold for opening and closing door.

END OF WORK PACKAGE

GENERAL

1. This work package contains instructions for safely operating the M977 Series, 8 X 8, Heavy Expanded Mobility Tactical Truck (HEMTT) with Crew Protection Kit installed.
2. Read and follow the procedures in *Operation Under Usual Conditions* in TM 9-2320-279-10 before operating with armor kit.

INITIAL ADJUSTMENTS AND DAILY CHECKS**NOTE**

Refer to WP 0004 00 for the location and operation of operator controls.

Perform *Before* operation Preventive Maintenance Checks and Services (PMCS) before operating vehicle (WP 0008 00 and WP 0009 00).

OPERATING HEMTT**WARNING**

- Due to increased weight of HEMTT with Crew Protection Kit installed, operator should be aware of differences in vehicle's driving characteristics and adjust driving accordingly. Failure to follow this warning may cause an accident and injury or death to personnel.
- Due to increased weight of doors, use extreme caution when opening and closing doors. If vehicle is parked on non-level ground, door may swing in direction of slope. Failure to follow this warning may cause injury to personnel.
- When placing foot on step to enter cab of vehicle, be aware of side blast deflector. Edge of side blast deflector protrudes outward beyond step. Failure to follow this warning may cause injury to personnel.

CAUTION

Do not place foot on top of side blast deflector when entering cab. Failure to follow this caution may cause damage to clearance light wires.

NOTE

During operation on rough roads, escape hatch may rattle or leak.

1. With Crew Protection Kit installed, vehicle is heavier than usual by approximately 2,491 lb (1130 kg). Due to this increased weight, adjust driving to allow for greater stopping distance. Adjust vehicle speed accordingly and exercise caution.
2. Vehicle exhibits oversteer characteristics at Gross Vehicle Weight (GVW); it will turn tighter than expected. To recover an oversteering HEMTT, accelerate vehicle and/or reduce steering wheel angle.
3. Visibility to the sides and rearward is reduced with armor kit installed. Approach intersections with caution and use assistance as needed to determine when intersection is clear and it is safe to proceed. Use ground guides when backing the vehicle.
4. Maintain good visibility for operating personnel. Keep ballistic glass at side door windows and windshield clean. Follow cleaning instructions in *Cleaning Ballistic Glass* (WP 0010 00).
5. Operate heater/air conditioning system as needed to ensure proper cab ventilation.

END OF WORK PACKAGE

OPERATION UNDER UNUSUAL CONDITIONS

0006 00

1. Read and follow the procedures in *Operation Under Unusual Conditions* in TM 9-2320-279-10 before operating the M977 Series, 8 X 8, Heavy Expanded Mobility Tactical Truck (HEMTT) with armor kit installed.
2. There are no additional specific instructions for operation under unusual conditions for the HEMTT Crew Protection Kit.

END OF WORK PACKAGE

STOWAGE AND DATA PLATES

There is no data plate guide or stowage guide specific to the Crew Protection Kit. Refer to TM 9-2320-279-10 for data plates and stowage.

DECALS

Decals located on ballistic glass that state “FAILURE TO FOLLOW CLEANING PROCEDURES CONTAINED IN TM 9-2320-280-10 WILL RESULT IN DAMAGE” have been superseded by the cleaning procedure in *Cleaning Ballistic Glass* (WP 0010 00).

END OF WORK PACKAGE

CHAPTER 3
OPERATOR MAINTENANCE INSTRUCTIONS

GENERAL**NOTE**

- Information in this PMCS Introduction applies only to preventive maintenance checks and services for the Crew Protection Kit.
 - For information specific to the M977 Series, 8 X 8, Heavy Expanded Mobility Tactical Truck (HEMTT), refer to the PMCS Introduction in TM 9-2320-279-10.
1. To ensure that the Crew Protection Kit is ready for operation at all times, it must be inspected on a regular basis so that defects may be found and corrected before they result in injury or death due to equipment failure.
 2. The PMCS Table in WP 0009 00 contains systematic instructions for inspections and services to keep equipment in good operating condition and ready for its primary mission.

EXPLANATION OF TABLE ENTRIES

1. **Item Number (Item No.) Column.** Numbers in this column are for reference. When completing DA Form 2404 or DA Form 5988-E (*Equipment Inspection and Maintenance Worksheet*), include the item number for the check/service indicating a fault. Item numbers also appear in the order in which you must perform checks and services for the interval listed.
2. **Interval Column.** This column tells you when you must perform the procedure in the Procedure column.
 - a. *Before* procedures must be done immediately before you operate vehicle with Crew Protection Kit installed.
 - b. *After* procedures must be done immediately after operating vehicle with Crew Protection Kit installed.
 - c. *Weekly* procedures must be done once each week.
3. **Location, Item to Check/Service Column.** This column provides the location and item to be checked or serviced.

NOTE

The WARNINGS and CAUTIONS appearing in your PMCS table should always be observed. WARNINGS and CAUTIONS appear before applicable procedures. You must observe these WARNINGS to prevent injury or death to personnel, and CAUTIONS to prevent your equipment from being damaged.

4. **Procedure Column.** This column includes the procedure you must perform to know if the equipment is ready or available for its intended mission. You must perform the procedure at the time stated in the Interval column.
5. **Not Fully Mission Capable If: Column.** Information in this column tells you what faults will keep your equipment from being capable of performing its primary mission. If you perform check/service procedures that show faults listed in this column, the equipment is not mission-capable. Follow standard operating procedures for maintaining the equipment or reporting equipment failure.

GENERAL PMCS PROCEDURES

1. Always perform PMCS in the same order. With experience, you should be able to identify problems easily.
2. If anything looks wrong and you can't fix it, write it on your DA Form 2404 or DA Form 5988-E. If you find something seriously wrong, IMMEDIATELY report it to your supervisor.
3. Before performing preventive maintenance, read all the checks required for the applicable interval and prepare everything needed to make all the checks. For example, you'll always need a rag (Item 7, WP 0035 00) or two.

**OPERATOR PREVENTIVE MAINTENANCE CHECKS AND SERVICES
(PMCS) INTRODUCTION - CONTINUED**

0008 00

GENERAL PMCS PROCEDURES - CONTINUED**WARNING**

Solvent cleaning compound MIL-PRF-680 Type III is an environmentally compliant and low toxic material. However, it may be irritating to the eyes and skin. Use protective gloves and goggles. Use in well-ventilated areas. Keep away from open flames and other sources of ignition. Failure to follow this warning may cause injury to personnel.

- a. **Keep It Clean.** Dirt, grease, oil, and debris get in the way and may cover up a serious problem. Clean as you work and as needed. Use solvent cleaning compound (Item 2, WP 0035 00) on all metal surfaces. Use detergent (Item 4, 0035 00) and water when you clean rubber, plastic, and painted surfaces.

**WARNING**

When servicing this machine, performing maintenance, or disposing of materials such as engine coolant, hydraulic fluid, lubricants, battery acids or batteries, and CARC paint, consult your unit/local hazardous waste disposal center or safety office for local regulatory guidance. If further information is needed, please contact The Army Environmental Hotline at 1-800-872-3845.

- b. **Hazardous Waste Disposal.** Ensure all spills are cleaned up and disposed of IAW local policy and ordinances.
- c. **Rust and Corrosion.** Check metal parts for rust and corrosion. If any bare metal or corrosion exists, clean and apply a light coat of clean lubricating oil (Item 5, WP 0035 00). Report it to your supervisor.
- d. **Bolts, Rivnuts, Nuts, and Screws.** Check bolts, rivnuts, nuts, and screws for obvious loose, missing, bent, or broken condition. If you find loose or missing components, notify your supervisor.
- e. **Electric Wires and Connectors.** Look for cracked or broken insulation, bare wires, and loose or broken connectors. Reconnect loose connectors. Ensure that wires are in good condition.

CAUTION

- Remove rings or other hard objects from hands before cleaning ballistic glass. **DO NOT** use hard, dirty, or gritty cloths on ballistic glass. **DO NOT** apply water or detergent unless ballistic glass is cool and is protected from heating effects of sunlight. Failure to follow these instructions will damage ballistic glass.
- Do not use bug spray or other aerosol sprays on or near ballistic glass. Failure to follow these instructions will damage ballistic glass.

- f. **Ballistic Glass.** Keep ballistic glass clean (WP 0010 00).

4. Inspection Procedures and Replacement Criteria for Armor and Ballistic Glass.

- a. **Metallic Armor.** Inspect for and replace the armor if any of the following conditions exist:
 - (1) Stage 3 rust spots are areas of corrosion which may indicate a rusted through condition (i.e., metal in corroded area is unsound and small pin holes are present).
 - (2) Stage 4 rust is a rust through condition.
 - (3) User modifications that have not been authorized by the Vehicle PM.

**OPERATOR PREVENTIVE MAINTENANCE CHECKS AND SERVICES
(PMCS) INTRODUCTION - CONTINUED**

0008 00

GENERAL PMCS PROCEDURES - CONTINUED

- (4) Examine areas around bolts and bolt holes for cracks or elongation of the holes. Cracks that are 1 inch or longer, or 2 consecutive bolt holes elongated are cause to replace the armor panel.
- (5) Look for signs that the armor has been deformed or damaged, including:
 - (a) Armor that is dented or bent out of shape.
 - (b) Bent door frames and door support posts which won't allow the doors to close properly.
 - (c) Bent, warped, or misaligned body panels that cause gaps between adjacent armor panels.
 - (d) Any complete penetration of the armor (a hole in the armor) or multiple gouges 1/4 inch or deeper within 3 inches of each other.
- b. **Ceramic/Composite Armor.** Inspect for and replace if there is any visible damage.
- c. **Transparent Armor (Ballistic Glass).** Inspect transparent armor for damage and replace if any of the following conditions exist:
 - (1) Cloudiness in the glass which interferes with the driver's vision.
 - (2) Rock chips, cracks with spider webbing, decals, or stickers that impair vision.
 - (3) Any hit that exposes the glass below the first layer.

END OF WORK PACKAGE

ITEM NO.	INTERVAL	LOCATION	PROCEDURE	NOT FULLY MISSION CAPABLE IF:
		ITEM TO CHECK/SERVICE		
1	Before		NOTE	
		<p>UNDER VEHICLE</p> <p>Underbody Armor</p>	<ul style="list-style-type: none"> • Perform PMCS for the M977 Series, 8 X 8, Heavy Expanded Mobility Tactical Truck (HEMTT) in TM 9-2320-279-10 BEFORE performing PMCS for the Crew Protection Kit. • Review all WARNINGS, CAUTIONS, and NOTES before performing PMCS and operating the vehicle with armor kit. • Perform all PMCS checks if: <ul style="list-style-type: none"> a. You are the assigned operator but have not operated the vehicle with armor kit since the last weekly checks. b. You are operating the vehicle with armor kit for the first time. • Perform PMCS with vehicle parked on level ground, parking brake applied, transmission in N (Neutral), wheels blocked, and engine shut down. 	
			Inspect driver-side, center, and passenger-side blast deflectors under vehicle for damage or loose or missing armor plates and mounting bolts.	Any blast deflector is damaged, loose, or missing, or mounting bolts are loose or missing.
				
			CENTER BLAST DEFLECTOR	SIDE BLAST DEFLECTOR
				417-041

ITEM NO.	INTERVAL	LOCATION	PROCEDURE	NOT FULLY MISSION CAPABLE IF:
		ITEM TO CHECK/SERVICE		
2	Before	FRONT AND LEFT SIDE	<p>a. Inspect louvered grille panels and upper and lower brush guards for damage or loose or missing armor plates and mounting bolts.</p> <p>b. Inspect headlight mounting hardware for damage or loose or missing brackets and mounting bolts.</p> <p>c. Inspect windshield ballistic glass mounting hardware for damage or loose or missing brackets and mounting bolts.</p> <p>d. Inspect exterior surface of windshield ballistic glass for pitting, cracks, or scratches.</p> <p>e. If dirty, clean windshield ballistic glass (WP 0010 00).</p>	<p>Any panel or armor plate is damaged, loose, or missing, or mounting bolts are loose or missing.</p> <p>Any windshield ballistic glass mounting hardware is damaged, loose, or missing, or mounting bolts are loose or missing.</p> <p>Pitting, cracks, or scratches exist in the exterior layer of windshield ballistic glass and penetrate through to the inner layer.</p>
		Front Armor		

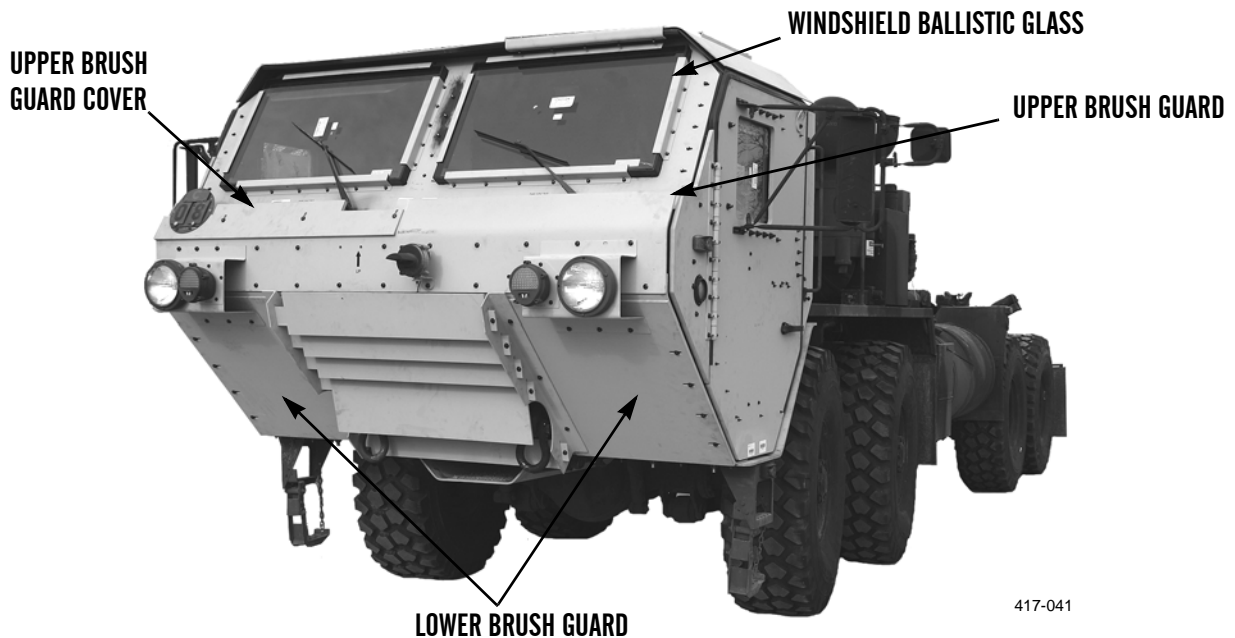

417-041

ITEM NO.	INTERVAL	LOCATION	PROCEDURE	NOT FULLY MISSION CAPABLE IF:
		ITEM TO CHECK/SERVICE		
3	Before	Side Armor (Left Side)	<p>a. Inspect side armor panels and door assembly for damage or loose or missing mounting hardware.</p> <p>b. Inspect exterior surface of door ballistic glass for pitting, cracks, or scratches.</p> <p>c. Open door and enter cab. Close door using grab handle. Lock door with lock pin. Make sure door closes without binding and locks correctly (WP 0004 00).</p> <p>d. Ensure door ballistic glass can open, close, and securely lock.</p> <p>e. Inspect interior surface of door ballistic glass and windshield ballistic glass for pitting, cracks, or scratches.</p> <p>f. If dirty, clean door ballistic glass (WP 0010 00).</p>	<p>Any side armor panel or door assembly is damaged or mounting hardware is loose or missing.</p> <p>Pitting, cracks, or scratches exist in the exterior layer of door ballistic glass and penetrate through to the inner layer.</p> <p>Door binds or does not lock.</p> <p>Door ballistic glass will not close or lock.</p> <p>Pitting, cracks, or scratches exist on the interior surface of the door ballistic glass or windshield ballistic glass.</p>

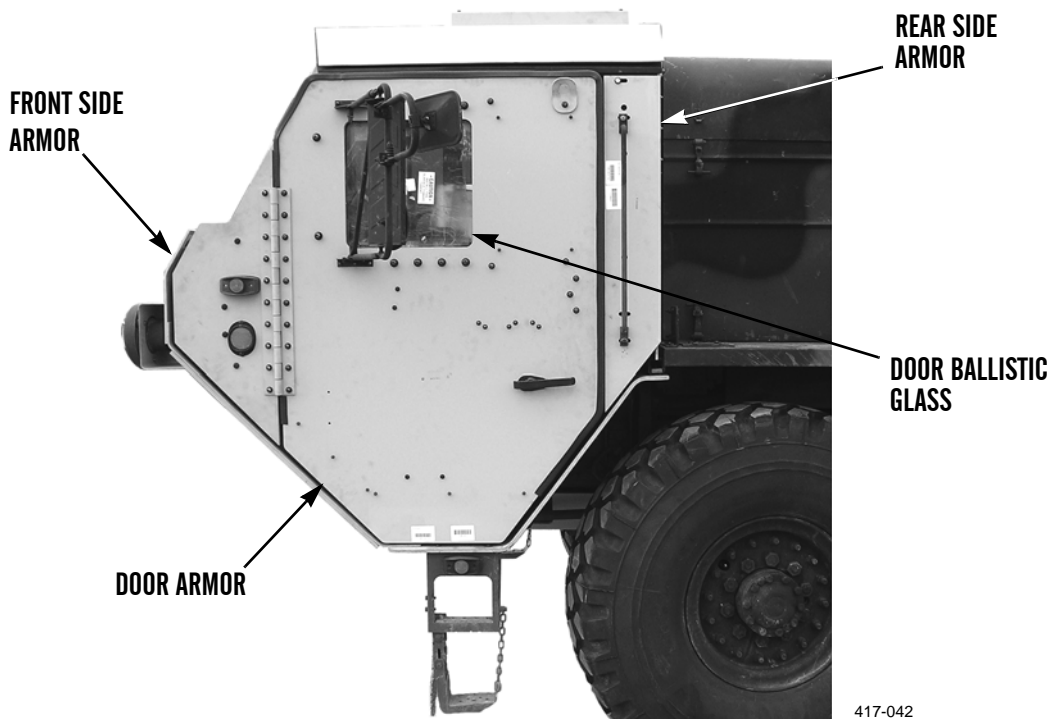

417-042

ITEM NO.	INTERVAL	LOCATION	PROCEDURE	NOT FULLY MISSION CAPABLE IF:
		ITEM TO CHECK/SERVICE		
4	Before	ROOF	a. Inspect roof armor for damage or loose or missing mounting bolts. b. Inspect escape hatch for damage.	Roof armor is damaged, loose, or missing, or mounting bolts are loose or missing. Escape hatch is missing or damaged.
		Roof Armor		

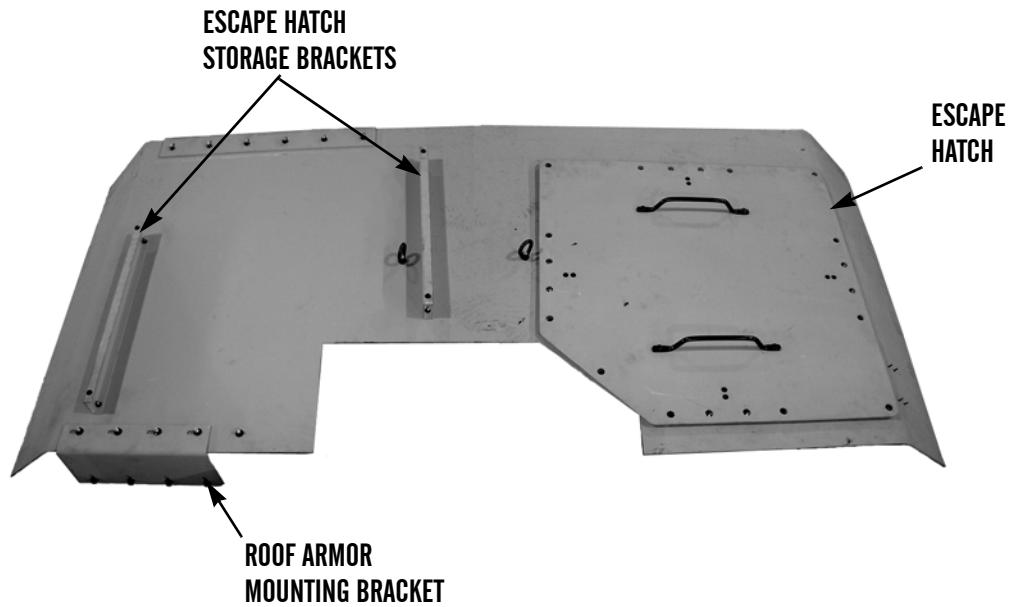

417-044

ITEM NO.	INTERVAL	LOCATION	PROCEDURE	NOT FULLY MISSION CAPABLE IF:
		ITEM TO CHECK/SERVICE		
5	Before	<p>REAR AND RIGHT SIDE</p> <hr/> <p>Rear Cab Armor</p>	Inspect rear cab armor for damage and loose or missing armor plates and mounting bolts.	Rear cab armor is damaged, loose, or missing, or mounting bolts are loose or missing.

REAR CAB ARMOR

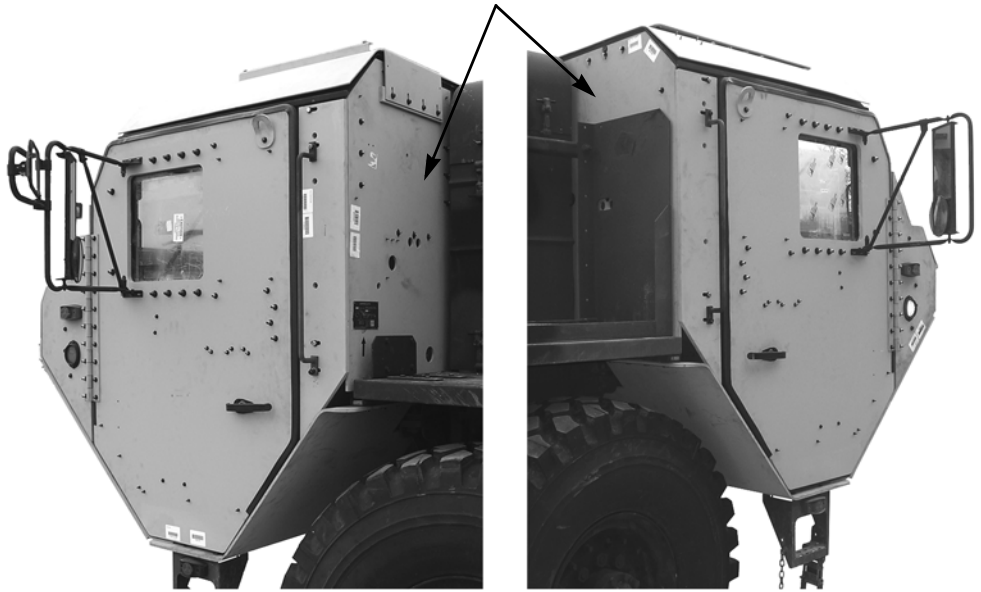

417-045

ITEM NO.	INTERVAL	LOCATION	PROCEDURE	NOT FULLY MISSION CAPABLE IF:
		ITEM TO CHECK/SERVICE		
6	Before	Side Armor (Right Side)	<p>a. Inspect side armor panels and door assembly for damage or loose or missing mounting hardware.</p> <p>b. Inspect exterior surface of door ballistic glass for pitting, cracks, or scratches.</p> <p>c. Open door and enter cab. Close door using grab handle. Lock door with lock pin. Make sure door closes without binding and locks correctly (WP 0004 00).</p> <p>d. Ensure door ballistic glass can open, close, and securely lock.</p> <p>e. Inspect interior surface of door ballistic glass and windshield ballistic glass for pitting, cracks, or scratches.</p> <p>f. If dirty, clean door ballistic glass (WP 0010 00).</p>	<p>Any side armor panel or door assembly is damaged or mounting hardware is loose or missing.</p> <p>Pitting, cracks, or scratches exist in the exterior layer of door ballistic glass and penetrate through to the inner layer.</p> <p>Door binds or does not lock.</p> <p>Door ballistic glass will not close or lock.</p> <p>Pitting, cracks, or scratches exist on the interior surface of the door ballistic glass or windshield ballistic glass.</p>

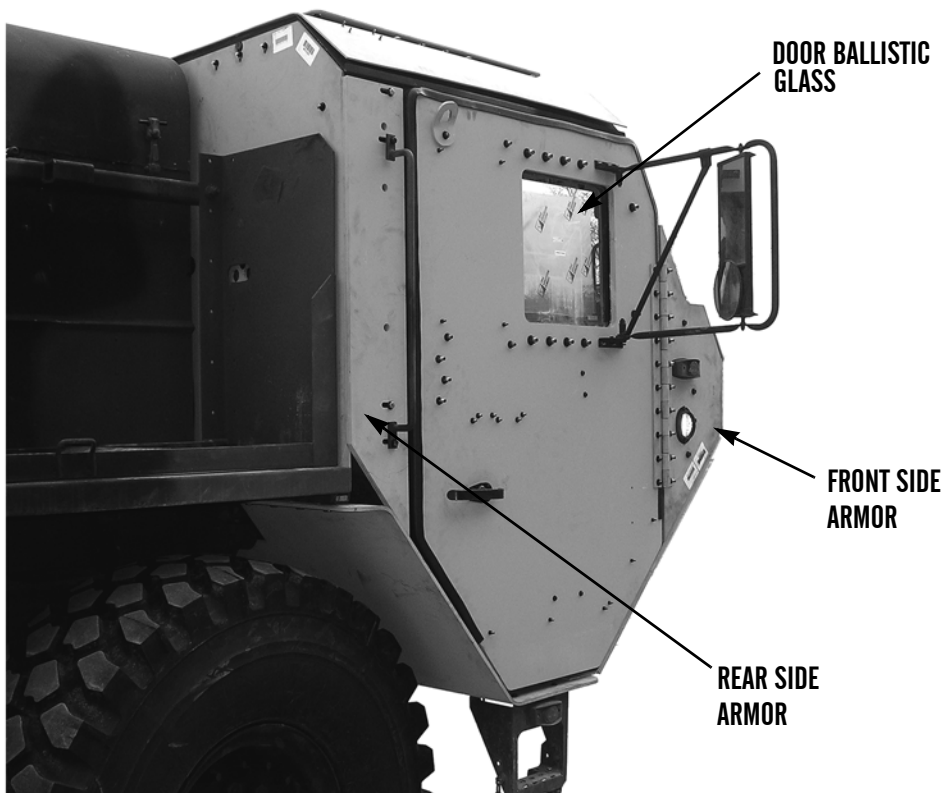

417-046

OPERATOR PREVENTIVE MAINTENANCE CHECKS AND SERVICES (PMCS) - CONTINUED

0009 00

ITEM NO.	INTERVAL	LOCATION	PROCEDURE	NOT FULLY MISSION CAPABLE IF:
		ITEM TO CHECK/SERVICE		
7	Before	Escape Hatch	Check that escape hatch is centered in roof opening and securely latched closed. Ensure there is no damage to latches and latch mounting hardware.	Escape hatch will not latch closed.



417-043

8	Weekly	Front Suspension	Inspect front suspension springs and mounting hardware for cracks, breaks, or loose or missing hardware and/or shackles. Notify your supervisor of any damage found.	Any cracks, breaks, loose hardware, or damage to suspension springs is noted.
---	--------	------------------	--	---

OPERATOR PREVENTIVE MAINTENANCE CHECKS AND SERVICES (PMCS) - CONTINUED

0009 00

ITEM NO.	INTERVAL	LOCATION	PROCEDURE	NOT FULLY MISSION CAPABLE IF:
		ITEM TO CHECK/SERVICE		
			NOTE	
			An indication of rear cab mount failure is evidence of wear or rubbing on side door above driver-side or passenger-side blast deflector.	
9	Weekly	Rear Cab Mounts	Inspect rear cab mounts for evidence of deterioration, overcompression, or loose mounting hardware. Notify your supervisor of any damage or looseness found.	
10	Weekly	Wheels and Wheel Rims	Inspect wheel lug nuts and wheel rim bolts/nuts for looseness (e.g., polished surface, rust, or minor cracks around bolt and wheel mating surfaces). Notify your supervisor of any looseness found.	Two or more studs or nuts are missing from the same wheel.
11	Weekly	Armor Kit Mounting Hardware	Check all armor kit mounting hardware for loose or missing hardware. Notify your supervisor of any loose or missing mounting hardware found.	
12	Weekly	Escape Hatch	a. Check that escape hatch is centered in roof opening and securely latched closed. Ensure there is no damage to latches and latch mounting hardware. b. Inspect for damage to escape hatch seal. Notify your supervisor of any damage found.	Escape hatch will not latch closed.
13	Weekly	Door Assemblies and Straps	Check both door assembly seals, hardware, and stop strap for damaged or loose components. Notify your supervisor of any damage found.	
14	Weekly	Center Blast Deflector	Check center blast deflector for evidence of contact with steering components. Notify your supervisor of any contact points found.	

END OF WORK PACKAGE

CLEANING BALLISTIC GLASS

0010 00

THIS WORK PACKAGE COVERS

Cleaning

INITIAL SETUP

Maintenance Level

Operator

Materials/Parts

- Detergent (Item 4, WP 0035 00)
- Rag, Wiping (Item 7, WP 0035 00)

Equipment Conditions

- Vehicle parked on level ground (TM 9-2320-279-10)
 - Parking/Emergency Brake applied (TM 9-2320-279-10)
 - Engine off (TM 9-2320-279-10)
 - If equipped, Battery Disconnect Switch in OFF position (TM 9-2320-279-10)
-

CLEANING

CAUTION

- Remove rings or other hard objects from hands before cleaning ballistic glass. **DO NOT** use hard, dirty, or gritty cloths on ballistic glass. **DO NOT** apply water or detergent unless ballistic glass is cool and is protected from heating effects of sunlight. Failure to follow these instructions will damage ballistic glass.
- Do not use bug spray or other aerosol sprays on or near ballistic glass. Failure to follow these instructions will damage ballistic glass.

NOTE

Follow this procedure to clean inner plastic laminate surfaces of ballistic glass. Clean outside surfaces of ballistic glass as you would clean plain glass.

1. Add detergent (as directed by manufacturer) to 1 gal. (3.8 L) of water.
2. Saturate a soft, clean cloth with cleaning solution and lightly rub plastic surfaces.
3. Flush off cleaning solution with water and dry with a soft, clean cloth.

END OF WORK PACKAGE

CHAPTER 4
UNIT MAINTENANCE INSTRUCTIONS

GENERAL MAINTENANCE INSTRUCTIONS

0011 00

THIS WORK PACKAGE COVERS

Scope	Standard Tool Requirements
Work Safety	Use of Thread Adhesive
General Information	Use of Sealant
Cleaning Instructions	Applying Torque
Inspection Instructions	Tagging Instructions
Repair Instructions	

INITIAL SETUP**Maintenance Level**

Unit

Tools and Special Tools

Tool Kit, General Mechanic's (Item 13, WP 0034 00)

Shop Equipment, Common No. 1 (Item 10, WP 0034 00)

Materials/Parts

Adhesive, Thread (Item 1, WP 0035 00)

Cleaning Compound, Solvent (Item 2, WP 0035 00)

Cloth, Abrasive (Item 3, WP 0035 00)

Detergent (Item 4, WP 0035 00)

Materials/Parts - Continued

Oil, Lubricating (Item 5, WP 0035 00)

Rag, Wiping (Item 7, WP 0035 00)

Tag, Marker (Item 10, WP 0035 00)

Tape, Pressure Sensitive Adhesive (Item 11, WP 0035 00)

References

TB 43-0209

TB 43-0242

TM 9-2320-279-10

TM 9-247

SCOPE

1. The general maintenance instructions contain general shop practices and specific methods you must be familiar with to properly install and maintain the Crew Protection Kit.
2. Read and understand these practices and methods before starting maintenance tasks on the armor kit.

WORK SAFETY

1. Before starting a task, think about the risks and hazards to your safety as well as others. Wear protective gear such as safety goggles, face shield, safety shoes, and gloves. Protect yourself against injury.
2. Observe all WARNINGS and CAUTIONS.
3. When lifting heavy parts, always use assistance. Ensure that lifting equipment is working properly, suitable for the task assigned, of sufficient load capacity, and secured against slipping.
4. Always use power tools carefully.

GENERAL MAINTENANCE INSTRUCTIONS - CONTINUED

0011 00

WORK SAFETY - CONTINUED

5. Before beginning a procedure, ensure that the following conditions have been observed, unless otherwise specified:
 - a. Vehicle must be parked on level ground with parking/emergency brake applied (TM 9-2320-279-10).
 - b. Transmission must be in N (Neutral) (TM 9-2320-279-10).
 - c. Engine must be off (TM 9-2320-279-10).
 - d. If equipped, battery disconnect switch must be in OFF position (TM 9-2320-279-10).

GENERAL INFORMATION

1. Before beginning a task, find out how much teardown is needed to fix the equipment as described in this manual. Sometimes complete teardown is not necessary. Remove components only as far as necessary to replace damaged or broken parts.
2. All tags and forms attached to the equipment must be checked to learn the reason for removal from service. Check all Modification Work Orders (MWOs) and Technical Bulletins (TBs) for equipment changes and updates.
3. Replace all locknuts and lockwashers.
4. Inspect seals for damage. Replace seals if damaged.

CLEANING INSTRUCTIONS

1. **General.**
 - a. The importance of cleaning must be thoroughly understood by maintenance personnel. Great care and effort are required in cleaning. Dirt and foreign material are a constant threat to satisfactory maintenance.
 - b. The following should apply to all cleaning operations:
 - (1) Keep all related parts and components together. Do not mix parts.
 - (2) Clean all parts before inspection and before installation.
 - (3) To prevent contamination, hands should be kept free of accumulation of grease, which can collect dust, dirt, or grit.

CLEANING INSTRUCTIONS - CONTINUED2. **Cleaning Instructions.****WARNING**

- Solvent cleaning compound MIL-PRF-680 Type III is an environmentally compliant and low toxic material. However, It may be irritating to the eyes and skin. Use protective gloves and goggles. Use in well-ventilated areas. Keep away from open flames and other sources of ignition. Failure to follow this warning may result in injury or death to personnel.
 - Improper cleaning methods and use of unauthorized cleaning solvents may injure personnel and damage equipment. Refer to TM 9-247, *Materials Used for Cleaning, Preserving, Abrading, and Cementing Ordnance Materiels and Related Materials Including Chemicals*, for correct information.
 - Fire extinguishers should be placed nearby when using solvent cleaning compound. Failure to follow this warning may result in injury or death.
 - Cloths or rags saturated with solvent cleaning compound must be disposed of IAW authorized facilities' procedures. Failure to follow this warning may result in injury.
 - Eye shields must be worn when cleaning with a wire brush. Flying rust and metal particles may cause injury.
 - Particles blown by compressed air are hazardous. DO NOT exceed 15 psi (103 kPa) nozzle pressure when drying parts with compressed air. Use a maximum of 30 psi (207 kPa) when cleaning components. DO NOT direct compressed air against human skin. Failure to follow this warning may result in injury or death. Make sure air stream is directed away from user and other personnel in the area. To prevent injury, user must wear protective goggles or face shield.
- a. Use solvent cleaning compound to clean any surface coated with grease or oil.
 - b. Clear out all drilled or tapped (threaded) holes with compressed air to remove dirt and solvent cleaning compound.
 - c. Use detergent and water to wash externally exposed parts that are not subject to grease and oil. Rinse thoroughly and air dry.
 - d. Use a wire brush and solvent cleaning compound to remove old sealing compound.
 - e. Use a wire brush and abrasive cloth to clean all rusted surfaces.
 - f. After cleaning, cover or wrap all parts to protect them from dust and dirt. Any part that is subject to rust should be lightly coated with clean lubricating oil.

INSPECTION INSTRUCTIONS

1. **General.** Inspect all components and parts carefully to determine if they are serviceable for reuse or if they must be replaced.
2. **Drilled and Tapped (Threaded) Holes.**
 - a. Inspect for wear, distortion (stretching), cracks, or any other damage in or around holes.
 - b. Inspect threaded areas for wear, distortion, or evidence of cross-threading.
 - c. If damage is noted, repair or replace as required.
3. **Armor Plates.**
 - a. Inspect for breaks, cracks, dents, and rust damage.
 - b. Particularly check areas around studs, screw openings, and sharp corners.

INSPECTION INSTRUCTIONS - CONTINUED**WARNING**

To ensure survivability of personnel, welding repairs on armor kit are NOT authorized. If armor plates are damaged, they must be replaced. Failure to follow this warning may cause failure of armor, resulting in injury or death to personnel.

- c. Replace any damaged armor plate. DO NOT repair by welding.
4. **Bolts and Screws.** Replace if threads are damaged, bent, loose, or stretched.
5. **Studs.** If studs are damaged, repair or replace as necessary.
6. **Rubber Seals.** Replace seal if damaged, cracked or shows signs of excessive wear.

PAINTING INSTRUCTIONS**CAUTION**

Whenever paint is applied, care must be taken to prevent covering up installation aid markings (**THIS SIDE UP**, up arrows ↑, etc.). These installation aid markings must be protected during paint application by using masking tape, paper, etc.

Parts must be painted in accordance with TB 43-0209, *Color, Marking, and Camouflage Painting of Military Vehicles, Construction Equipment, and Materials Handling Equipment*, and TB 43-0242, *CARC Spot Painting*.

STANDARD TOOL REQUIREMENTS

1. The following are general practices regarding the use of tools:
 - a. Always use the proper tool kit and tools for the procedure being performed.
 - b. Ensure that tools are clean and lubricated to reduce wear and prevent rust.
 - c. Keep track of tools. Do not be careless with them.
 - d. Return tools to toolbox when finished with repair or maintenance.
 - e. Return toolboxes and tools to tool storage when not in use.
 - f. Inventory tools before and after each use.
2. Some maintenance tasks may require special or fabricated tools. The “Initial Setup” of the procedure will specify any special or fabricated tools needed to perform that procedure. Use these special tools only for the maintenance procedures for which they are designed or specified. If you are unfamiliar with a required tool, see your supervisor.

USE OF THREAD ADHESIVE**WARNING**

Use caution when using adhesives and sealants. Prolonged inhalation of vapors can cause lung irritation. Contact with skin can cause dermatitis. Wear gloves and safety goggles and use product in a well-ventilated area away from open flame. If ingested, keep individual calm and seek medical attention. DO NOT induce vomiting. If contact with skin or eyes is made, flush thoroughly with water. Dispose of cleanup rags IAW local policy and ordinances. Failure to follow this warning may cause injury to personnel.

1. All nuts, bolts, and screws used in the installation of the armor kit or when replacing armor kit components must be coated with Thread Adhesive (Item 1, WP 0035 00), unless otherwise stated.
2. Locknuts supplied with the kit do not require thread adhesive.

USE OF SEALANT

1. When applying sealant, follow manufacturer's instructions on label of container.
2. Sealant should be applied in an even and continuous 1/4 inch bead along mating surfaces.

APPLYING TORQUE

1. When tightening fasteners, use torque value as specified in *Torque Limits* (WP 0036 00).
2. If a unique torque value is required, it will be provided in the procedural step of the task.

TAGGING INSTRUCTIONS

1. Use marker tags to identify all electrical wires and any other parts that may be hard to identify or replace later. Fasten tags to parts during removal by wrapping wire fasteners around or through parts and twisting ends together. Position tags to be out of the way during cleaning, inspection, and repair. Mark tags with a pencil, pen, or marker.
2. Whenever possible, identify electrical wires with the number of the terminal or wire to which it connects. If no markings can be found, tag both wires or wire and terminal, and use the same identifying mark for both. If you cannot tag a wire because it must fit through a small hole or you cannot reach it, write down the description of the wire and the point to which it connects, or draw a simple diagram on paper. Be sure to write down enough information so you will be able to properly connect the wires during assembly. If you need to identify a loose wire, look for identifying number near end of the wire, stamped on a permanent metal tag. Compare the number to wire numbers on the appropriate electrical schematic.
3. Identify and tag other parts as required by name and installed location.

END OF WORK PACKAGE

THIS WORK PACKAGE COVERS

Removal, Cleaning and Inspection, Installation

INITIAL SETUP

Maintenance Level

Unit

Tools and Special Tools

Tool Kit, General Mechanic's (Item 13, WP 0034 00)

Materials/Parts

Rag, Wiping (Item 7, WP 0035 00)

Locknut

References

WP 0011 00

Equipment Conditions

Vehicle parked on level ground (TM 9-2320-279-10)

Parking/Emergency Brake applied (TM 9-2320-279-10)

Engine off (TM 9-2320-279-10)

If equipped, Battery Disconnect Switch in OFF position (TM 9-2320-279-10)

NOTE

The following procedure is for left door assembly. Right door assembly is identical.

REMOVAL

1. Open door assembly.
2. Remove locknut (9) and washer (10) from door cam (7) and position link rod (11) aside. Discard locknut.
3. Loosen setscrew (4) and remove interior grab handle (6), door cam (7), and bolt (8).
4. Remove four capscrews (2), washers (3), interior handle spacer (5), and exterior door handle (1).

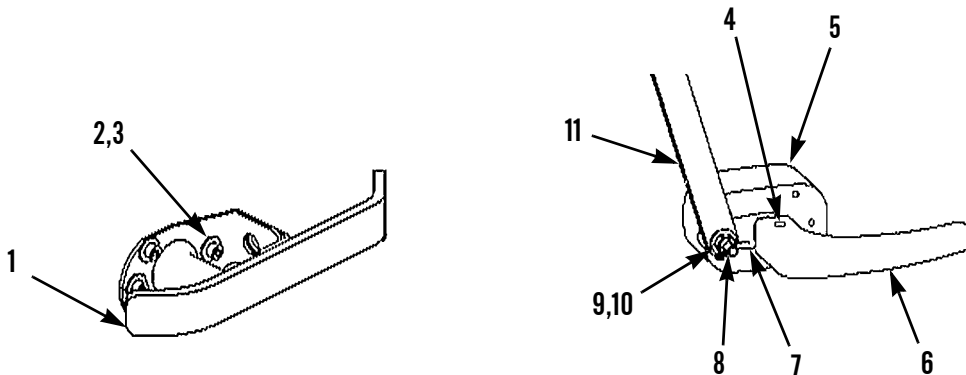

417-030

CLEANING AND INSPECTION

Clean and inspect all parts IAW *General Maintenance Instructions* (WP 0011 00).

INSTALLATION

1. Position interior handle spacer (5) and exterior door handle (1) on door assembly.
2. Install four washers (3) and capscrews (2) on exterior door handle (1).
3. Install bolt (8) on door cam (7).
4. Install door cam (7) and interior grab handle (6). Tighten setscrew (4).
5. Position link rod (11) on bolt (8) and install washer (10) and new locknut (9).

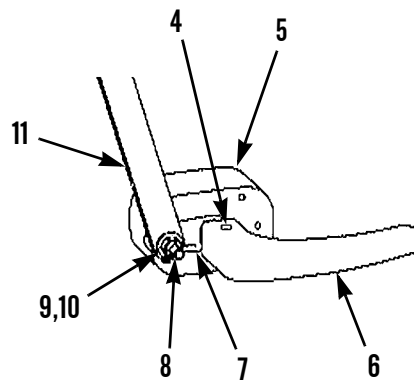
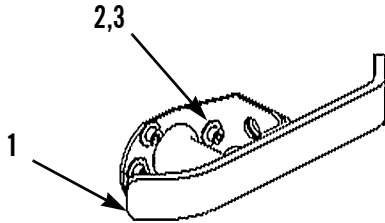

417-030

6. Operate door handle to verify correct operation.

END OF WORK PACKAGE

THIS WORK PACKAGE COVERS

Removal, Cleaning and Inspection, Installation

INITIAL SETUP

Maintenance Level

Unit

References

WP 0004 00

WP 0011 00

Tools and Special Tools

Tool Kit, General Mechanic's (Item 13, WP 0034 00)

Equipment Conditions

Vehicle parked on level ground (TM 9-2320-279-10)

Parking/Emergency Brake applied (TM 9-2320-279-10)

Engine off (TM 9-2320-279-10)

If equipped, Battery Disconnect Switch in OFF position (TM 9-2320-279-10)

Materials/Parts

Rag, Wiping (Item 7, WP 0035 00)

Locknut

NOTE

The following procedure is for left door handle assembly. Use same procedure for right door handle assembly.

REMOVAL

1. Remove spring (3) from cam (7).
2. Remove locknut (8) and disconnect link rod (2) from cam (7). Discard locknut.
3. Remove spring pin (6), inside handle (4), cam (7), and nut (5) from door (1).

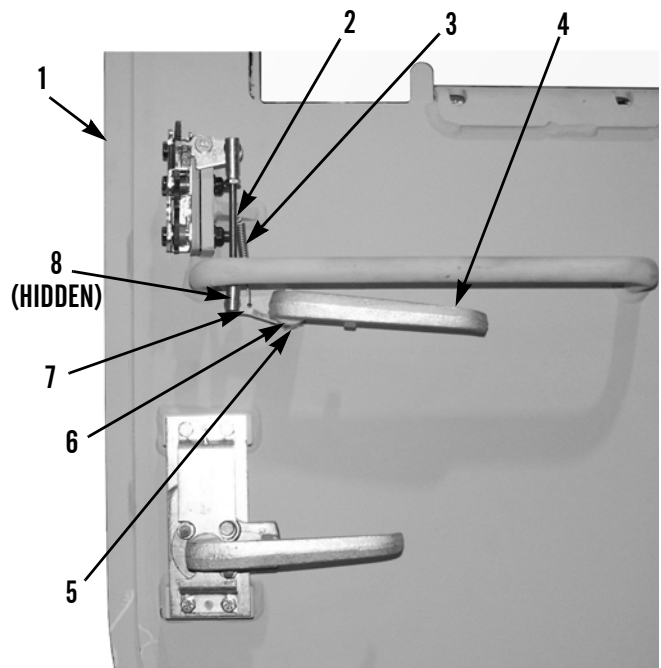

440-050

REMOVAL - CONTINUED

4. Remove spring pin (9), outside handle (10), shaft (11), and nut (15) from door (1).
5. Remove bolt (13), washer (14), and padlock bracket (12) from door (1).

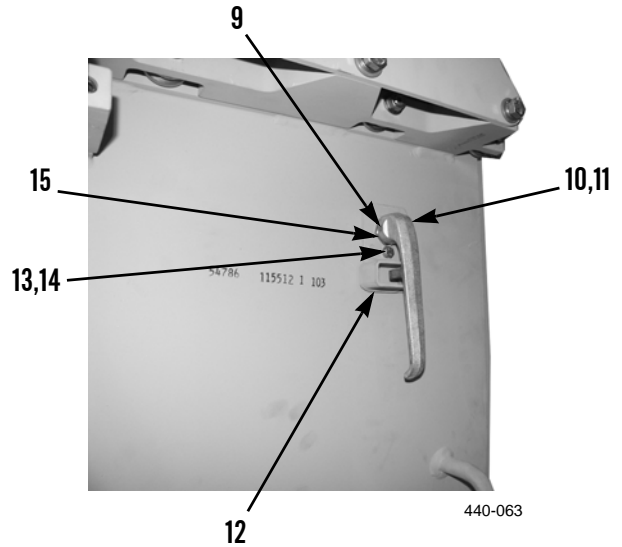

CLEANING AND INSPECTION

Clean and inspect all parts IAW *General Maintenance Instructions* (WP 0011 00).

INSTALLATION

1. Install padlock bracket (12), washer (14), and bolt (13) on door (1).
2. Install shaft (11), nut (15), outside handle (10), and spring pin (9) on door (1).
3. Install nut (5), cam (7), inside handle (4), and spring pin (6) on door (1).
4. Connect link rod (2) and install new locknut (8) on cam (7).
5. Connect spring (3) to cam (7).

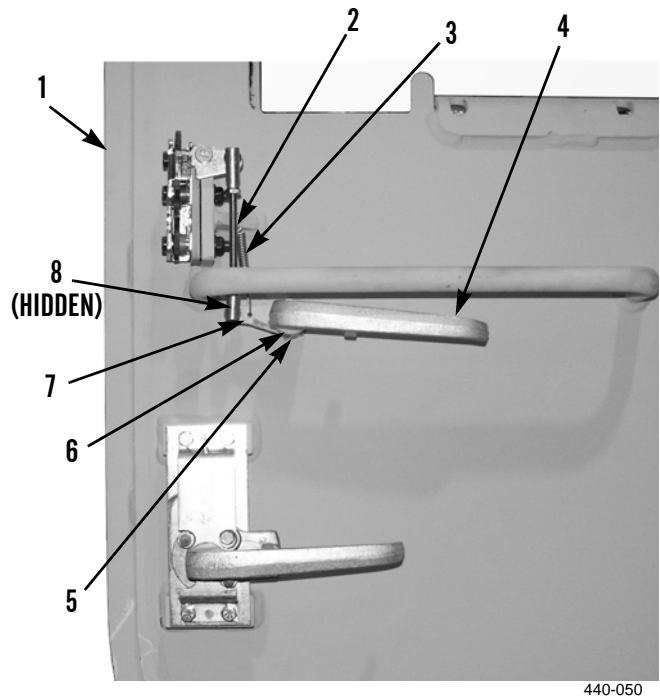

6. Verify correct operation of door assembly (WP 0004 00).

END OF WORK PACKAGE

DOOR LATCH AND LOCK PIN REPLACEMENT

0013 00**THIS WORK PACKAGE COVERS**Removal, Cleaning and Inspection, Installation

INITIAL SETUP**Maintenance Level**

Unit

Tools and Special Tools

Tool kit, General Mechanic's (Item 13, WP 0034 00)

Materials/Parts

Rag, Wiping (Item 7, WP 0035 00)

Locknut (13)

References

WP 0011 00

Equipment Conditions

Vehicle parked on level ground (TM 9-2320-279-10)

Parking/Emergency Brake applied (TM 9-2320-279-10)

Engine off (TM 9-2320-279-10)

If equipped, Battery Disconnect Switch in OFF position (TM 9-2320-279-10)

NOTE

The following procedure is for right door latch and lock pin. Left door latch and lock pin are identical.

DOOR LATCH AND LOCK PIN REPLACEMENT - CONTINUED

0013 00

REMOVAL

1. Open door assembly.
2. Disconnect spring (1) from link rod (15).
3. Remove locknut (4), bolt (2), and washer (3) from door latch (5). Discard locknut.
4. Remove three locknuts (8), washers (9), bolts (6), washers (7), and door latch (5). Discard locknuts.
5. Remove three locknuts (14), washers (13), bolts (11), washers (12) and latch bracket (10) from door. Discard locknuts.
6. Remove two locknuts (22), washers (21), bolts (19), washers (20) and bracket (23) from door. Discard locknuts.
7. Remove lock pin (16) from brackets (17 and 18).
8. Remove four locknuts (22), washers (21), bolts (19), washers (20) and brackets (17 and 18). Discard locknuts.

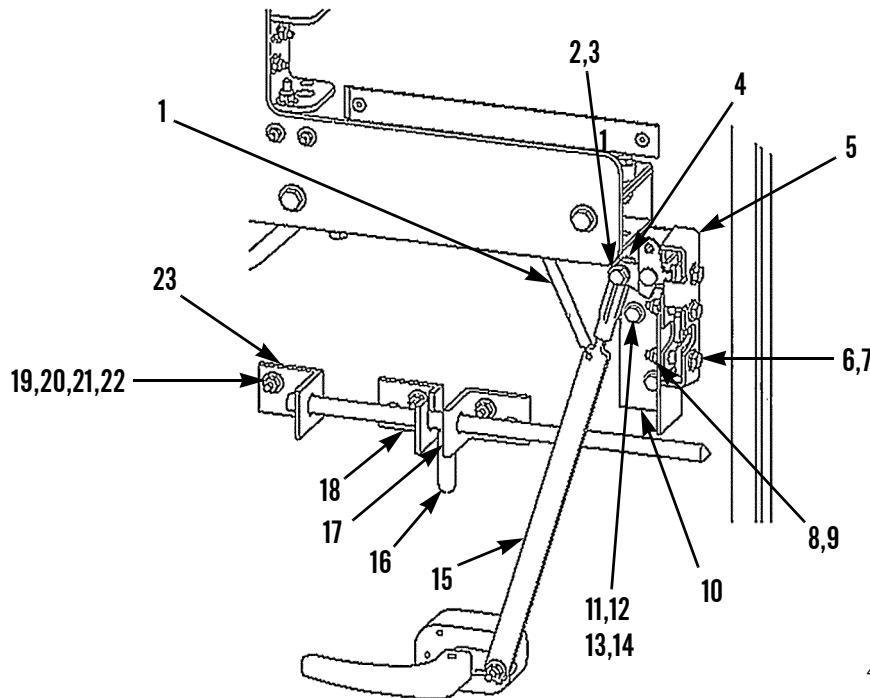

417-031

CLEANING AND INSPECTION

Clean and inspect all parts IAW *General Maintenance Instructions* (WP 0011 00).

INSTALLATION

1. Install brackets (17 and 18), four washers (20), bolts (19), washers (21), and new locknuts (22) on door.
2. Install lock pin (16) in brackets (17 and 18).
3. Install bracket (23), two washers (20), bolts (19), washers (21), and new locknuts (22) on door. Install latch bracket (10), three washers (12), bolts (11), washers (13), and new locknuts (14) on door.
4. Install door latch (5) with three washers (7), bolts (6), washers (9), and new locknuts (8).
5. Position link rod (15) and install washer (3), bolt (2), and new locknut (4) on door latch (5).
6. Connect spring (1) to link rod (15).
7. Operate door handle and lock pin to verify correct operation (WP 0004 00).

END OF WORK PACKAGE

DOOR LATCH AND COMBAT LOCK REPLACEMENT - MODEL B

0013 01**THIS WORK PACKAGE COVERS**Removal, Cleaning and Inspection, Installation

INITIAL SETUP**Maintenance Level**

Unit

References

WP 0004 00

WP 0011 00

Tools and Special ToolsTool Kit, General Mechanic's (Item 13, WP 0034
00)**Equipment Conditions**Vehicle parked on level ground (TM 9-2320-279-
10)Parking/Emergency Brake applied (TM 9-2320-
279-10)**Materials/Parts**

Rag, Wiping (Item 7, WP 0035 00)

Engine off (TM 9-2320-279-10)

Locknut (4)

If equipped, Battery Disconnect Switch in OFF
position (TM 9-2320-279-10)

NOTE

The following procedure is for left door latch and combat lock. Use same procedure for right side.

DOOR LATCH AND COMBAT LOCK REPLACEMENT - MODEL B - CONTINUED

0013 01

REMOVAL

1. Disconnect spring (7) from door (8).
2. Remove locknut (3) and disconnect link rod (6) from latch (2). Discard locknut.
3. Remove three locknuts (4), washers (5), bolts (1), and latch (2) from door (8). Discard locknuts.

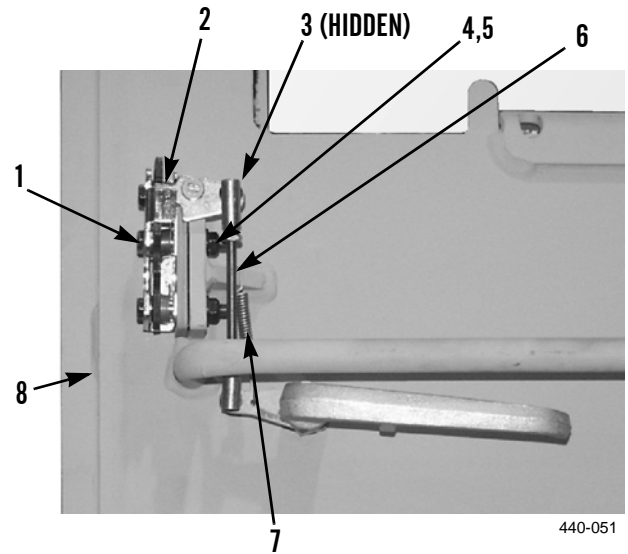

4. Remove four bolts (10), washers (11), and combat lock (9) from door (8).

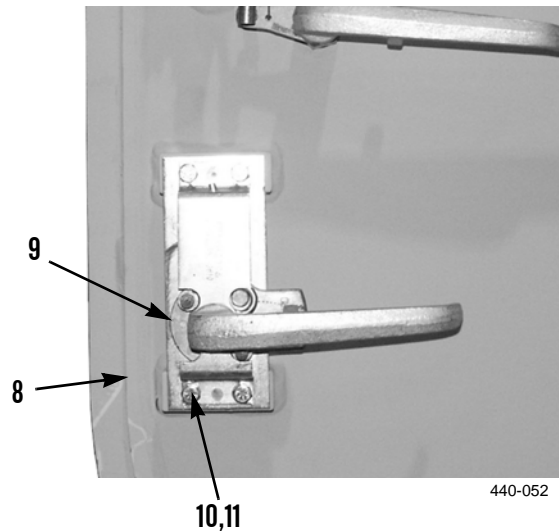
**CLEANING AND INSPECTION**

Clean and inspect all parts IAW *General Maintenance Instructions* (WP 0011 00).

INSTALLATION

1. Install combat lock (9), four washers (11), and bolts (10) on door (8).
2. Install latch (2), three bolts (1), washers (5), and new locknuts (4) on door (8).
3. Connect link rod (6) and install new locknut (3) on latch (2).
4. Connect spring (7) to door (8).
5. Verify correct operation of door assembly (WP 0004 00).

END OF WORK PACKAGE

DOOR BALLISTIC GLASS AND FRAME ASSEMBLY REPLACEMENT

0014 00

THIS WORK PACKAGE COVERS

Removal, Cleaning and Inspection, Installation

INITIAL SETUP

Maintenance Level

Unit

Personnel Required

Two

Tools and Special Tools

Tool Kit, General Mechanic's (Item 13, WP 0034 00)

Equipment Conditions

Vehicle parked on level ground (TM 9-2320-279-10)

Materials/Parts

Rag, Wiping (Item 7, WP 0035 00)

Locknut (34)

Parking/Emergency Brake applied (TM 9-2320-279-10)

Engine off (TM 9-2320-279-10)

References

WP 0011 00

If equipped, Battery Disconnect Switch in OFF position (TM 9-2320-279-10)

NOTE

The following procedure is for left door ballistic glass. Right door ballistic glass is identical.

REMOVAL

1. Open door assembly and open door ballistic glass (1).

NOTE

Door ballistic glass handle will lower into channel after bolt is removed.

2. Remove locknut (9), washer (10), bolt (11) and washer (12). Discard locknut.

NOTE

It may be necessary to cut bracket (8) approximately 0.5 in. (1.3 cm) to allow handle to rotate.

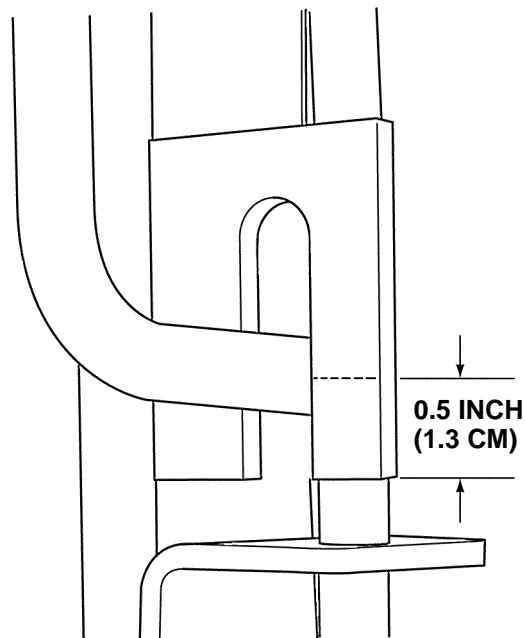

417-138

REMOVAL - CONTINUED

3. Pull handle (2) down and rotate toward hinge edge of door.
4. Remove bolt (3), spacer (4), locknut (5), and washer (6) from bottom channel (7). Discard locknut.

**WARNING**

Use caution when handling heavy parts. Provide adequate support and use assistance during procedure. Keep clear of heavy parts supported only by lifting device. Failure to follow this warning may cause injury or death to personnel.

NOTE

Door ballistic glass weighs 75 lb (34 kg).

5. With assistance, lift up on handle (2) and remove door ballistic glass (1) by sliding it out end of channel (7).

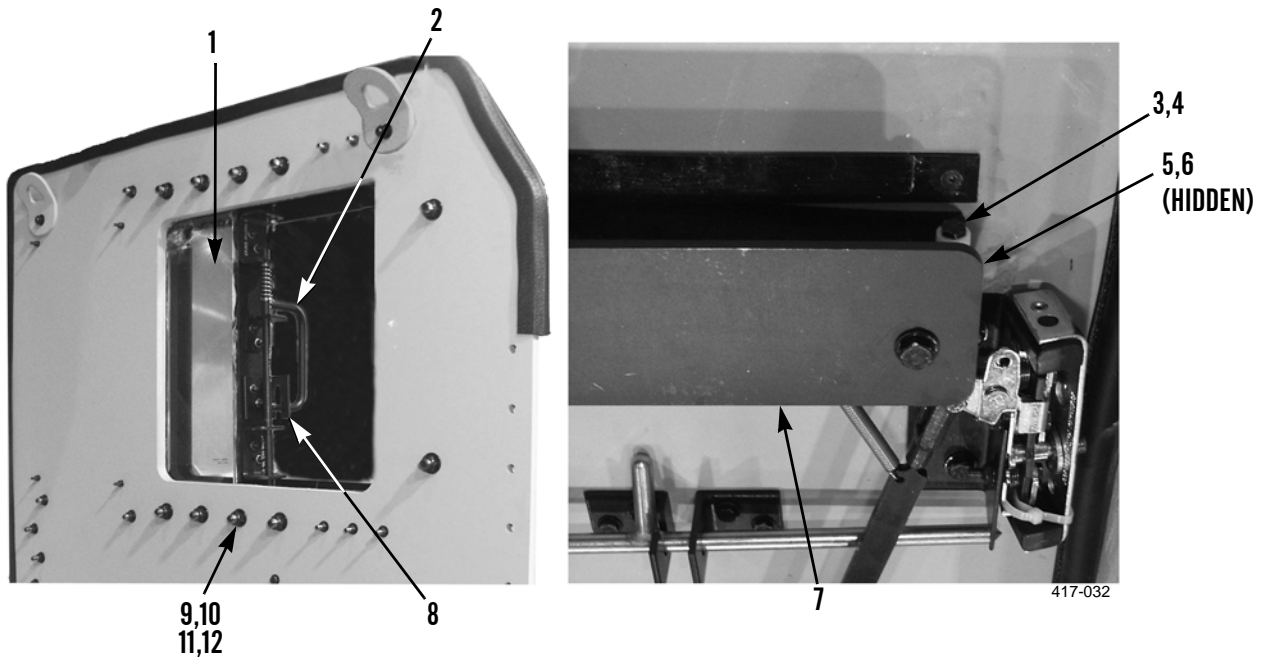

REMOVAL - CONTINUED

6. Remove two locknuts (37), washers (38), capscrews (53), washers (54), and sleeves (39) from door (40). Discard locknuts.
7. Remove seven remaining locknuts (9), washers (10), bolts (11), washers (12), and two doublers (57) from retainer (17). Discard locknuts.
8. Remove six locknuts (35), washers (36), bolts (55), washers (56), and lift bracket (28) from door (40). Discard locknuts.
9. Remove locknut (29), washer (30), lift bracket (28), bolt (13), and washer (14) from retainer (17). Discard locknut.



WARNING

The following step will release the retainer and supports from the door. Use assistance to support components while removing the attaching hardware. Failure to follow this warning may cause injury to personnel.

10. With assistance, remove three locknuts (33), washers (34), bolts (15), washers (16), retainer (17), support (22), and support (44) from door (40). Discard locknuts.
11. Remove three bolts (26), washers (27), and doubler (23) from support (22).
12. Remove bolt (47) and washer (48) from support (44).
13. Remove two capscrews (50), washers (51), handle (52), and doubler (49) from support (44).
14. Remove eight locknuts (18), washers (19), screws (21), and four ramps (20) from retainer (17). Discard locknuts.
15. Remove locknut (45), washer (46), capscrew (41), spacer (42), and guide (43) from support (44). Discard locknut.
16. Remove four locknuts (31), washers (32), screws (24) and two ramps (25) from door (40). Discard locknuts.

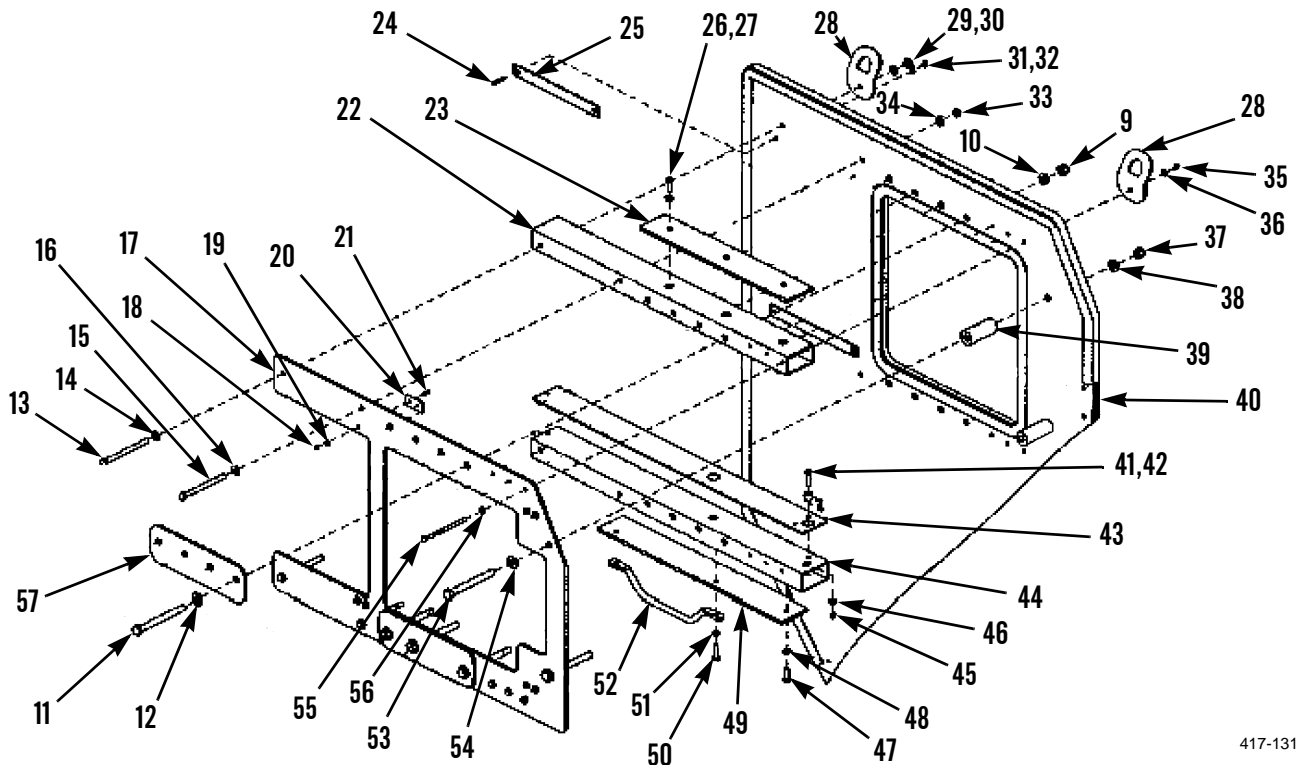

417-131

CLEANING AND INSPECTION

Clean and inspect all parts IAW *General Maintenance Instructions* (WP 0011 00).

INSTALLATION

1. Install two ramps (25), four screws (24), washers (32), and new locknuts (31) on door (40).
2. Install guide (43), spacer (42), capscrew (41), washer (46), and new locknut (45) on support (44).
3. Install four ramps (20), eight screws (21), washers (19), and new locknuts (18) on retainer (17).
4. Install doubler (49), handle (52), two washers (51), and capscrews (50) on support (44).
5. Install washer (48) and bolt (47) on support (44).
6. Install doubler (23), three washers (27), and bolts (26) on support (22).

**WARNING**

Use caution when handling heavy parts. Provide adequate support and use assistance during procedure. Keep clear of heavy parts supported only by lifting device. Failure to follow this warning may cause injury or death to personnel.

7. With assistance, install support (44), support (22), retainer (17), three washers (16), bolts (15), washers (34), and new locknuts (33) on door (40).
8. Install washer (14), bolt (13), lift bracket (28), washer (30), and new locknut (29) on retainer (17).
9. Install lift bracket (28), six washers (56), bolts (55), washers (36), and new locknuts (35) on door (40).
10. Install two doublers (57), seven washers (12), bolts (11), washers (10), and new locknuts (9) on retainer (17).
11. Install two sleeves (39), washers (54), capscrews (53), washers (38), and new locknuts (37) on door (40).

INSTALLATION - CONTINUED**WARNING**

- Use caution when handling heavy parts. Provide adequate support and use assistance during procedure. Keep clear of heavy parts supported only by lifting device. Failure to follow this warning may cause injury or death to personnel.
- For proper threat protection, door ballistic glass must be correctly installed into door frame. During installation, ensure that stencil marking "INSIDE OF VEHICLE" is located on inside of cab. Improperly installed door ballistic glass will not protect occupants. Failure to follow this warning may cause injury or death to personnel.

NOTE

Door ballistic glass weighs 75 lb (34 kg).

12. With assistance, install door ballistic glass (1) by sliding into end of channel (7).

NOTE

It may be necessary to cut bracket (8) approximately 0.5 in. (1.3 cm) to allow handle to rotate.

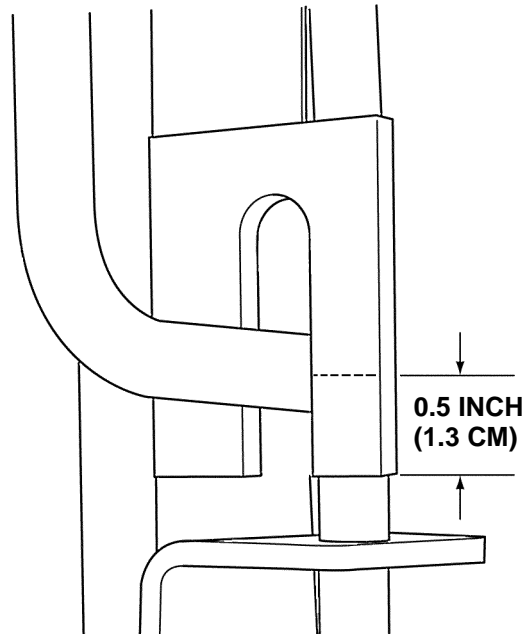

417-138

INSTALLATION - CONTINUED

13. When door ballistic glass (1) is near center position, lower handle (2) into center lock hole and rotate handle outward.
14. Lift handle (2) out of center lock hole and close door ballistic glass (1).
15. Install spacer (4), bolt (3), washer (6), and new locknut (5) in bottom channel (7).
16. Install washer (12), bolt (11), washer (10) and new locknut (9).

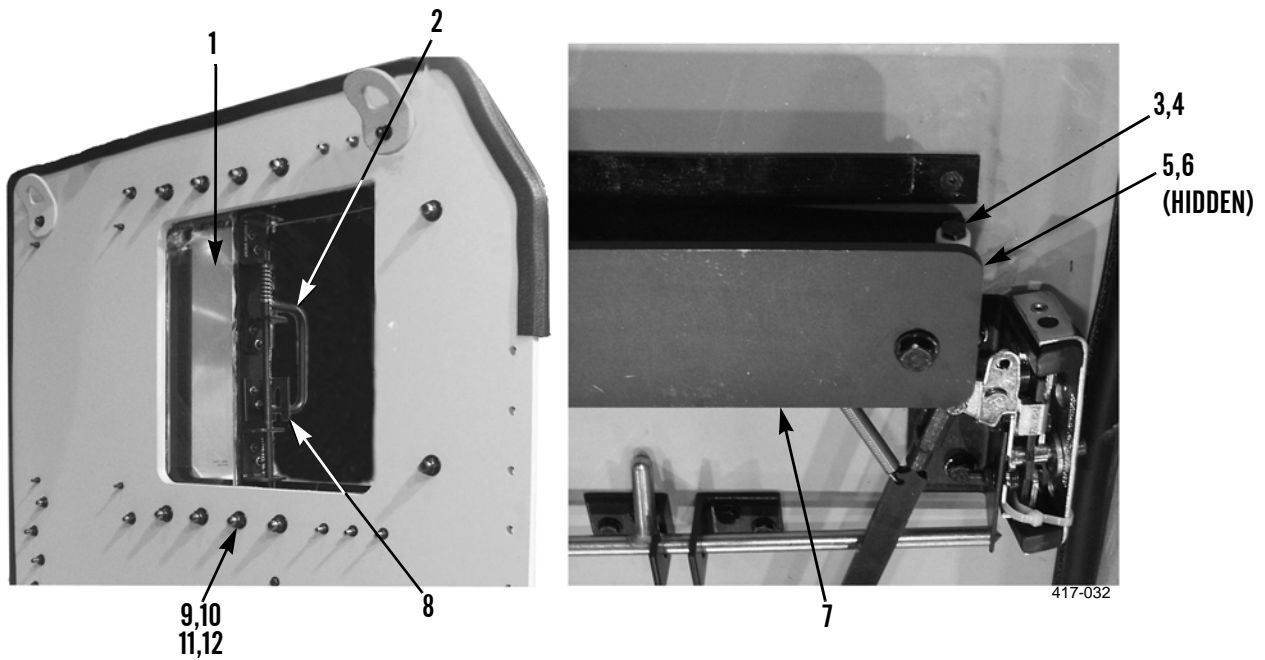

17. Operate door ballistic glass (1) to verify correct operation.

END OF WORK PACKAGE

THIS WORK PACKAGE COVERS

Removal, Cleaning and Inspection, Installation

INITIAL SETUP

Maintenance Level

Unit

Tools and Special Tools

Tool Kit, General Mechanic's (Item 13, WP 0034 00)

Materials/Parts

Rag, Wiping (Item 7, WP 0035 00)

Locknut (18)

Lockwasher (8)

References

WP 0004 00

References - Continued

WP 0011 00

Personnel Required

Two

Equipment Conditions

Vehicle parked on level ground (TM 9-2320-279-10)

Parking/Emergency Brake applied (TM 9-2320-279-10)

Engine off (TM 9-2320-279-10)

If equipped, Battery Disconnect Switch in OFF position (TM 9-2320-279-10)

NOTE

The following procedure is for left door ballistic glass. Use same procedure for right door ballistic glass.

REMOVAL

1. Remove nut (2), spring (3), and door window latch (1) as an assembly from ballistic glass frame (4).

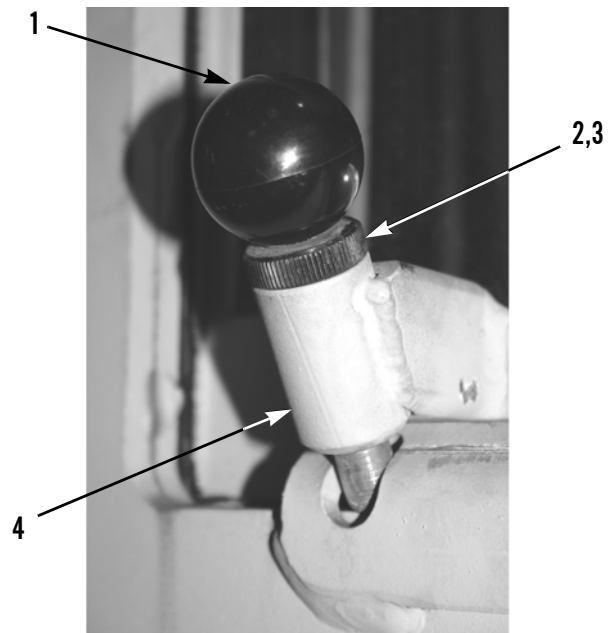

440-053

REMOVAL - CONTINUED

- Remove four bolts (6), lockwashers (7), washers (8), and upper support (5) from ballistic glass cover (9). Discard lockwashers.

**WARNING**

Use extreme caution when handling heavy parts. Provide adequate support and use assistance during procedure. Failure to follow this warning may cause injury or death to personnel.

CAUTION

Use caution when handling ballistic glass. Protect surfaces when stored.

NOTE

- Only loosen bolts enough to remove ballistic glass from lower support.
 - Mark outside surface before removal if re-installing ballistic glass.
- With assistance, loosen four bolts (11), remove ballistic glass (10) from lower support (14), and place glass on flat surface.
 - With assistance, remove four bolts (11), lockwashers (12), washers (13), ballistic glass cover (9), and lower support (14) from door. Discard lockwashers.
 - Remove 18 locknuts (20), bolts (18), washers (19), and two ballistic glass frames (21) from ballistic glass (10). Discard locknuts.

**WARNING**

Use extreme caution when handling heavy parts. Provide adequate support and use assistance during procedure. Failure to follow this warning may cause injury or death to personnel.

- With assistance, remove ballistic glass (10) from ballistic glass frame (4).
- Remove 10 nuts (15), washers (16), and rollers (17) from supports (5 and 14).

REMOVAL - CONTINUED

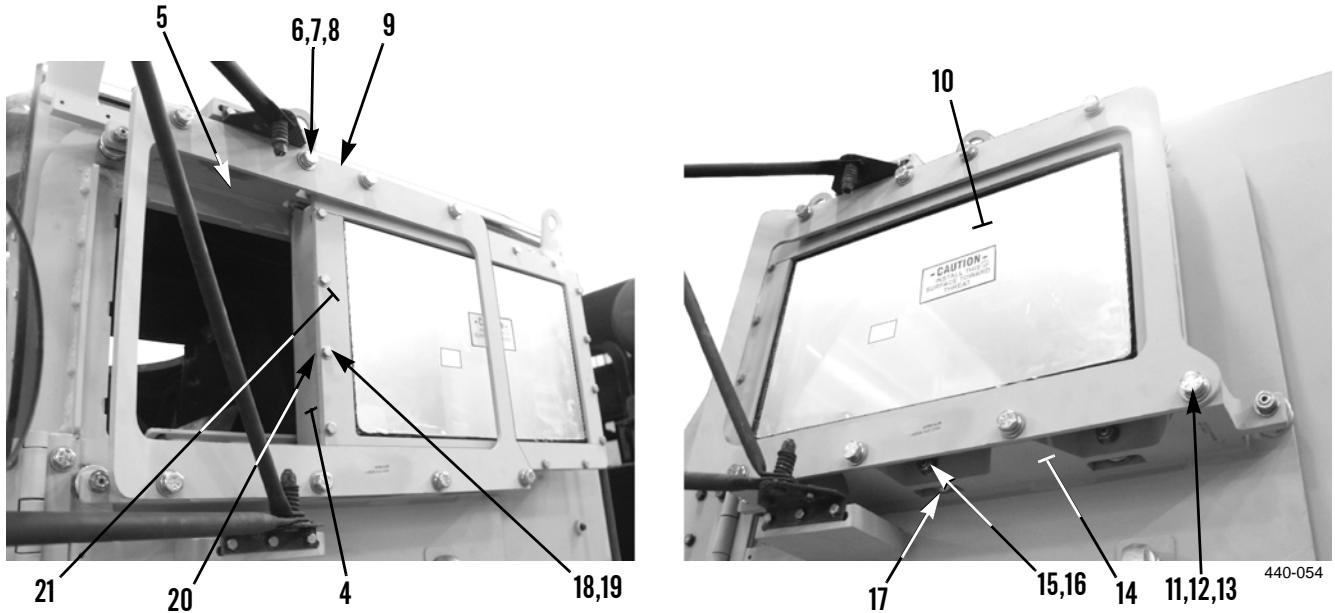

CLEANING AND INSPECTION

Clean and inspect all parts IAW *General Maintenance Instructions* (WP 0011 00).

INSTALLATION

1. Install 10 rollers (17), washers (16), and nuts (15) on supports (5 and 14).



WARNING

- Use extreme caution when handling heavy parts. Provide adequate support and use assistance during procedure. Failure to follow this warning may cause injury or death to personnel.
- For proper threat protection, ballistic glass must be correctly installed onto frame. During installation, ensure that decal marking “INSTALL THIS SURFACE TOWARDS THREAT” is located on outside of cab. Improperly installed ballistic glass will not protect occupants. Failure to follow this warning may cause injury or death to personnel.

CAUTION

Use caution when handling ballistic glass.

2. With assistance, install ballistic glass (10) in ballistic glass frame (4).
3. Install two ballistic glass frames (21), 18 washers (19), bolts (18), and new locknuts (20) on ballistic glass (10).

INSTALLATION - CONTINUED



WARNING

Use extreme caution when handling heavy parts. Provide adequate support and use assistance during procedure. Failure to follow this warning may cause injury or death to personnel.

NOTE

Install bolts loosely to allow enough clearance to install ballistic glass and frame.

4. With assistance, loosely install lower support (14), ballistic glass cover (9), four washers (13), new lockwashers (12), and bolts (11) on door.
5. With assistance, position ballistic glass (10) on lower support (14).
6. With assistance, install upper support (5), four washers (8), new lockwashers (7), and bolts (6) on ballistic glass cover (9).
7. Tighten four bolts (11) on ballistic glass cover (9).

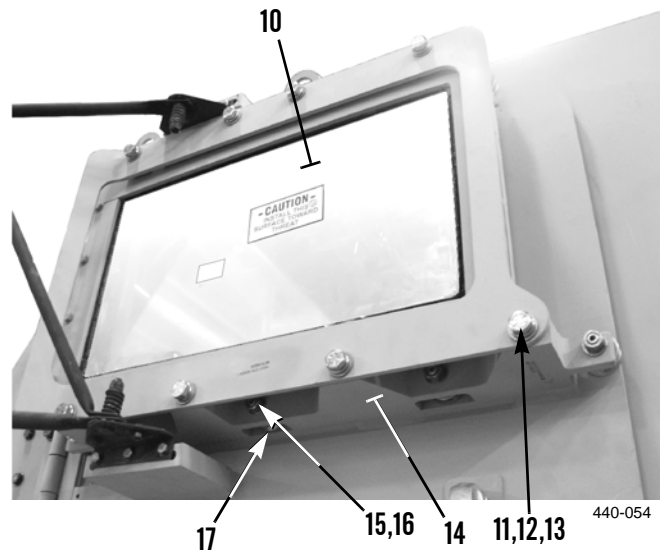
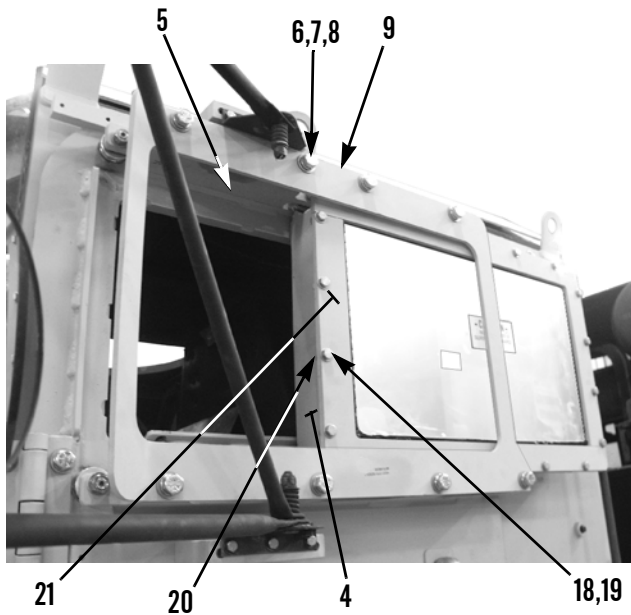

INSTALLATION - CONTINUED

8. Install spring (3), door window latch (1), and nut (2) as an assembly on ballistic glass frame (4).

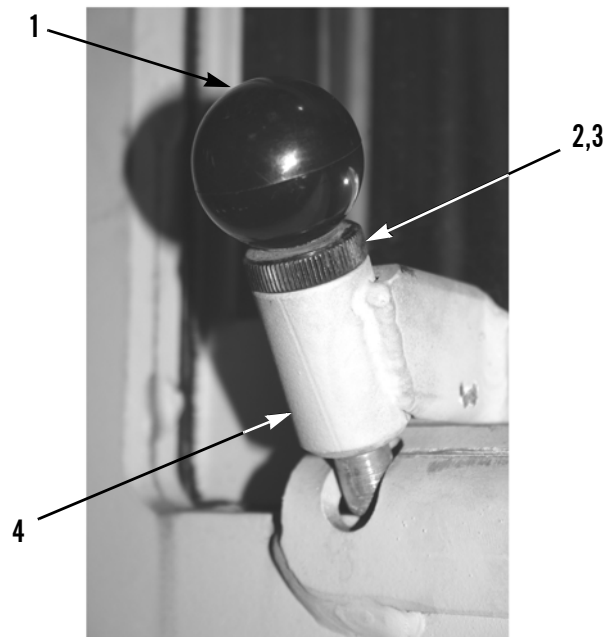

440-053

9. Operate door ballistic glass (10) to verify correct operation (WP 0004 00).

END OF WORK PACKAGE

DOOR ASSEMBLY REPLACEMENT

0015 00

THIS WORK PACKAGE COVERS

Removal, Cleaning and Inspection, Installation

INITIAL SETUP

Maintenance Level

Unit

Tools and Special Tools

Tool Kit, General Mechanic's (Item 9, WP 0034 00)

Shop Equipment, Common No. 1 (Item 6, WP 0034 00)

Sling (Item 7, WP 0034 00)

Lifting Device, 500-lb capacity

Materials/Parts

Adhesive (Item 1, WP 0035 00)

Rag, Wiping (Item , WP 0035 00)

Locknut (12)

References

WP 0011 00

WP 0016 00

WP 0039 00

Personnel Required

Two

Equipment Conditions

Vehicle parked on level ground (TM 9-2320-279-10)

Parking/Emergency Brake applied (TM 9-2320-279-10)

Engine off (TM 9-2320-279-10)

Battery Disconnect Switch in OFF position (TM 9-2320-279-10)

If installing new Door Assembly, remove Exterior Rearview Mirror (TM 9-2320-279-20)

NOTE

The following procedure is for right door assembly. Left door assembly is identical.

DOOR ASSEMBLY REPLACEMENT - CONTINUED**0015 00****REMOVAL**

1. Open door assembly (1) and remove bolt (2), washer (3), and strap assembly (4) from top of door assembly.
2. If strap assembly (4) is damaged, remove locknut (9), washer (8), bolt (5), washer (6), two bushings (7) and strap assembly from door frame. Discard locknut.

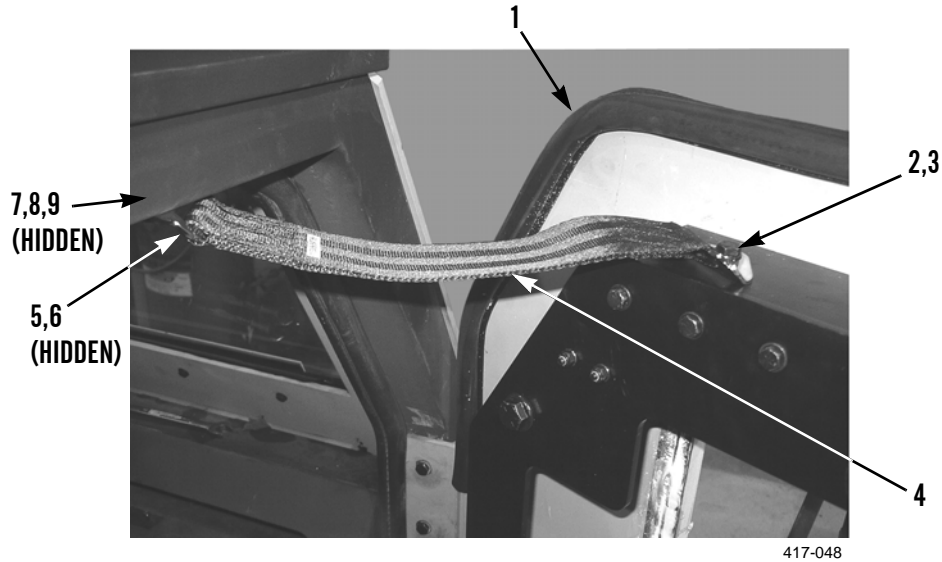
**NOTE**

It may be necessary to install lifting links at top of door assembly.

3. If necessary, install two lifting links (13), washers (11), bolts (10), and locknuts (12) on door assembly (1).

**WARNING**

Use extreme caution when handling heavy parts. Provide adequate support and use assistance during procedure. Ensure that any lifting device used is in good condition and of suitable load capacity. Keep clear of heavy parts supported only by lifting device. Failure to follow this warning may cause injury or death to personnel.

NOTE

Door assembly weighs 310 lb (141 kg).

4. Attach sling and lifting device to lifting links (13) at top of door assembly (1).

DOOR ASSEMBLY REPLACEMENT - CONTINUED

0015 00

REMOVAL - CONTINUED

5. Remove 10 locknuts (14), washers (15), and bolts (16) from door assembly (1). Discard locknuts.
6. Use lifting device to remove door assembly (1) from door frame and place on flat surface.
7. Remove sling and lifting device from door assembly (1).
8. Remove two locknuts (12), washers (11), bolts (10), and lifting links (13). Discard locknuts.

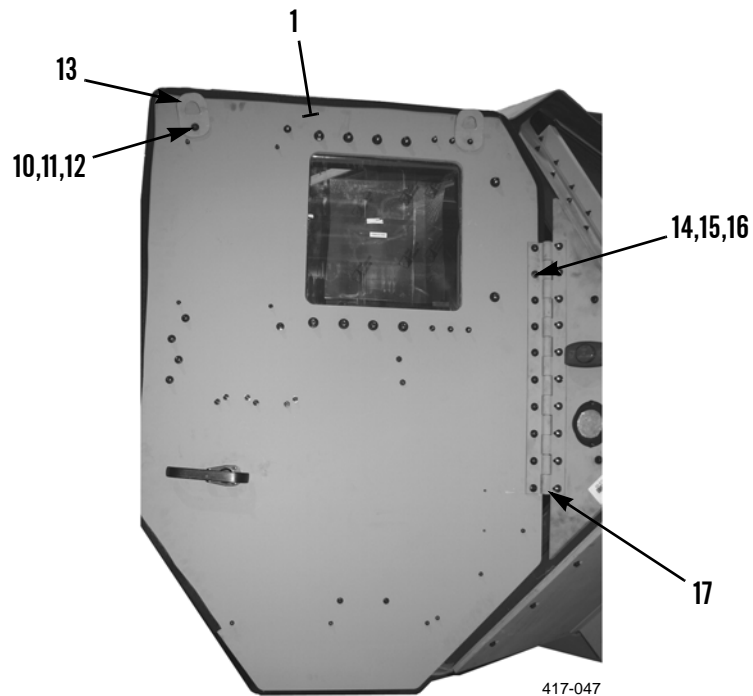
**CLEANING AND INSPECTION**

Clean and inspect all parts IAW *General Maintenance Instructions* (WP 0011 00).

INSTALLATION**WARNING**

Use extreme caution when handling heavy parts. Provide adequate support and use assistance during procedure. Ensure that any lifting device used is in good condition and of suitable load capacity. Keep clear of heavy parts supported only by lifting device. Failure to follow this warning may cause injury or death to personnel.

NOTE

Door assembly weighs 310 lb (141 kg).

1. If necessary, install two lifting links (13), washers (11), bolts (10), and new locknuts (12) on door assembly (1).
2. Attach sling and lifting device to lift links (13) at top of door assembly (1). Take up slack in sling.
3. Use lifting device to position door assembly (1) on hinge (17).
4. Install 10 bolts (16), washers (15), and new locknuts (14) through hinge mounting holes on door assembly (1). Hand tighten locknuts.
5. Check alignment between door assembly (1) and cab opening. Adjust door assembly as necessary until alignment is correct.
6. Tighten 10 locknuts (14) to 18 lb-ft (24 Nm).
7. Remove sling and lifting device from lifting links (13).

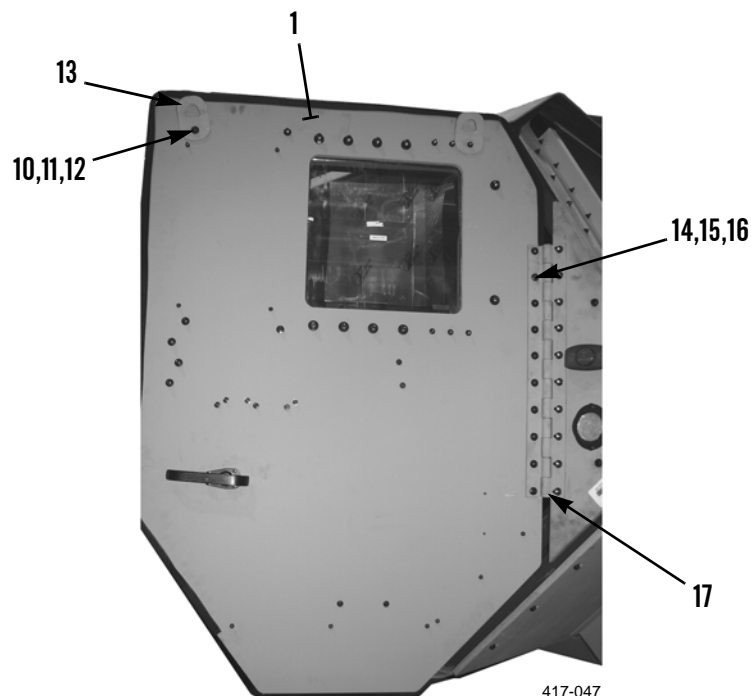

INSTALLATION - CONTINUED**NOTE**

- Perform step 8 if strap assembly was removed from door frame.
 - If door frame is new, refer to *Crew Protection Kit Installation Instructions* (WP 0039 00) for instructions on drilling holes in frame for installation of strap assembly.
8. Install strap assembly (4) on door frame with two bushings (7), washer (6), bolt (5), washer (8), and new locknut (9).



Use caution when using adhesives and sealants. Prolonged inhalation of vapors can cause lung irritation. Contact with skin can cause dermatitis. Wear gloves and safety goggles and use product in a well-ventilated area away from open flame. If ingested, keep individual calm and seek medical attention. DO NOT induce vomiting. If contact with skin or eyes is made, flush thoroughly with water. Dispose of cleanup rags IAW local policy and ordinances. Failure to follow this warning may cause injury to personnel.

9. Apply thread adhesive to bolt (2). Install strap assembly (4), washer (3), and bolt (2) on door assembly.

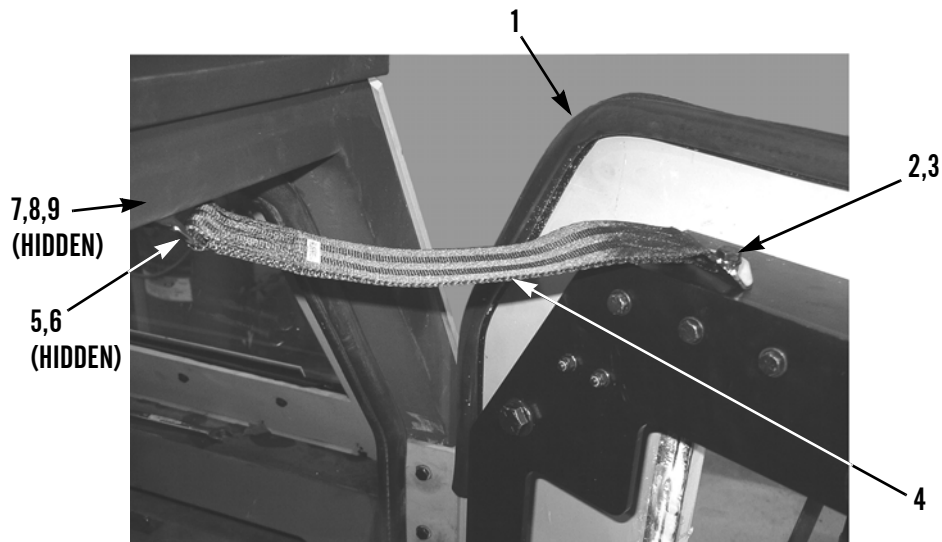

10. Adjust latch as necessary (WP 0016 00).
11. Verify correct operation of door assembly.
12. If removed, install outside mirror on door assembly (TM 9-2320-279-20).

END OF WORK PACKAGE

DOOR ASSEMBLY REPLACEMENT - MODEL B

0015 01

THIS WORK PACKAGE COVERS

Removal, Cleaning and Inspection, Installation

INITIAL SETUP

Maintenance Level

Unit

Personnel Required

Two

Tools and Special Tools

Tool Kit, General Mechanic's (Item 13, WP 0034 00)

Shop Equipment, Common No. 1 (Item 10, WP 0034 00)

Sling, Nylon (Item 7, WP 0034 00)

Device, Lifting, 500-lb Capacity

Equipment Conditions

Vehicle parked on level ground (TM 9-2320-279-10)

Parking/Emergency Brake applied (TM 9-2320-279-10)

Engine off (TM 9-2320-279-10)

Battery Disconnect Switch in OFF position (TM 9-2320-279-10)

Materials/Parts

Rag, Wiping (Item 7, WP 0035 00)

If installing new Door Assembly, remove Exterior Mirror (TM 9-2320-279-20)

References

WP 0004 00

WP 0011 00

NOTE

The following procedure is for left door assembly. Use same procedure for right door assembly.

DOOR ASSEMBLY REPLACEMENT - MODEL B - CONTINUED

0015 01

REMOVAL

1. Remove two bolts (8) and washers (9) from door stop (5).
2. Remove two bolts (6), washers (7), and door stop (5) from side of vehicle.
3. Unlatch door and attach sling and lifting device to lifting link (3) at top of door assembly (4).

**WARNING**

Use extreme caution when handling heavy parts. Provide adequate support and use assistance during procedure. Ensure that any lifting device used is in good condition and of suitable load capacity. Keep clear of heavy parts supported only by lifting device. Failure to follow this warning may cause injury or death to personnel.

NOTE

Door assembly weighs 336 lb (153 kg).

4. Using lifting device, remove five bolts, (1), washers (2), and door assembly (4) from door hinge (10).
5. Place door assembly (4) on flat surface and remove sling and lifting device.
6. Remove three bolts (11), washers (12), and hinge (10) from side of vehicle.

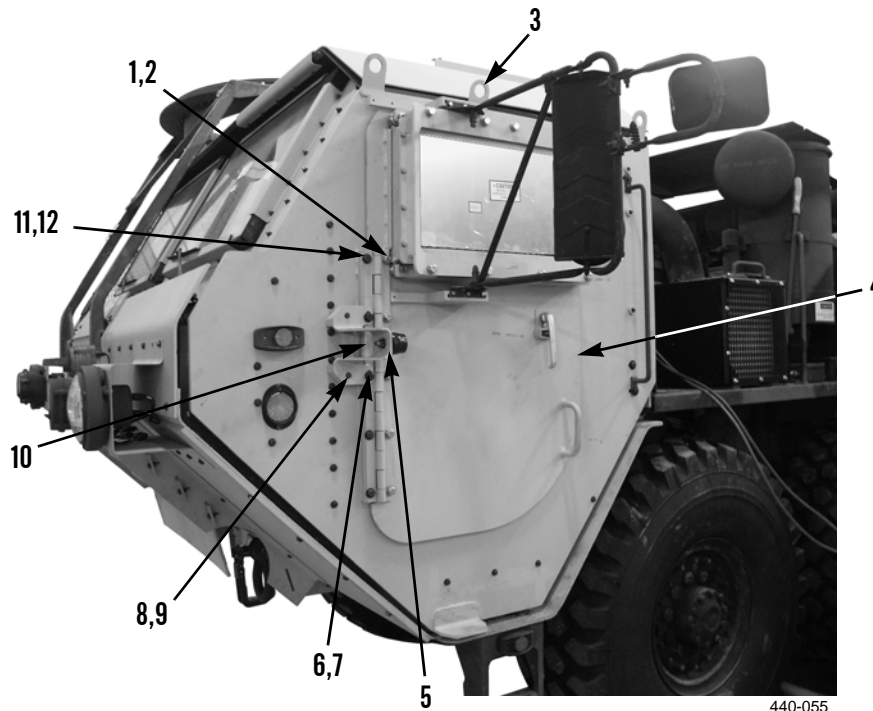
**CLEANING AND INSPECTION**

Clean and inspect all parts IAW *General Maintenance Instructions* (WP 0011 00).

INSTALLATION**NOTE**

Only install top bolt and two bottom bolts on door hinge. The remaining two bolt holes will be used for the door stop.

1. Install door hinge (10), three washers (12), and bolts (11) on side of vehicle.
2. Install door stop (5), two washers (7), and bolts (6) on door hinge (10).
3. Install two washers (9) and bolts (8) on door hinge stop(s) (10).

**WARNING**

Use extreme caution when handling heavy parts. Provide adequate support and use assistance during procedure. Ensure that any lifting device used is in good condition and of suitable load capacity. Keep clear of heavy parts supported only by lifting device. Failure to follow this warning may cause injury or death to personnel.

NOTE

Door assembly weighs 336 lb (153 kg).

4. Attach sling and lifting device to lifting link (3) at top of door assembly (4).
5. Use lifting device to position door assembly (4) on door hinge (10).
6. Install five washers (2) and bolts (1) on door assembly (4).
7. Remove sling and lifting device from lifting link (3).
8. Verify correct operation of door assembly (WP 0004 00).
9. If removed, install outside mirror on door assembly (TM 9-2320-279-20).

END OF WORK PACKAGE

DOOR LATCH ADJUSTMENT

0016 00

THIS WORK PACKAGE COVERS

Adjustment

INITIAL SETUP

Maintenance Level

Unit

Equipment Conditions

Vehicle parked on level ground (TM 9-2320-279-10)

Tools and Special Tools

Tool Kit, General Mechanic's (Item 13, WP 0034 00)

Parking/Emergency Brake applied (TM 9-2320-279-10)

Materials/Parts

Rag, Wiping (Item 7, WP 0035 00)

Engine off (TM 9-2320-279-10)

Locknut (4)

If equipped, Battery Disconnect Switch in OFF position (TM 9-2320-279-10)

ADJUSTMENT**NOTE**

When horizontal and vertical adjustments are correct, the upper lever (1) and lower lever (4) will contact the striker at the same time.

1. From inside cab, slowly close door and observe latch (2) and striker contact points.
2. If vertical adjustment is necessary, loosen three vertical adjustment bolts (3) and correctly position latch (2).
3. If loosened, tighten three bolts (3).
4. If horizontal adjustment is necessary, remove three locknuts, (9), washers (8), bolts (6) and washers (7) from latch bracket (5). Discard locknuts.
5. Add washers between latch bracket (5) and door to correctly position latch (2).
6. If removed, install three washers (7), bolts (6), washers (8), and new locknuts (9) on latch bracket (5).

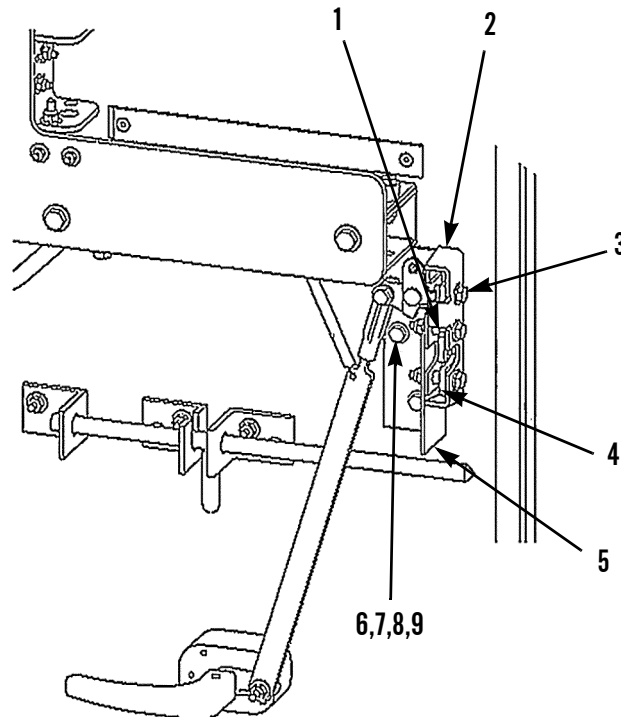

417-031

ADJUSTMENT - CONTINUED**NOTE**

When link rod adjustment is correct, the latch lever (14) will be touching the actuating lever (15).

7. If link rod (10) adjustment is necessary, remove locknut (13), washer (12), and bolt (11) from end of link rod. Discard locknut.
8. Rotate link rod (10) counterclockwise to bring latch lever (14) down.
9. Rotate link rod (10) clockwise to bring latch lever (14) up.
10. Align link rod (10) with hole in latch lever (14) and install bolt (11), washer (12) and new locknut (13) in end of link rod (10).

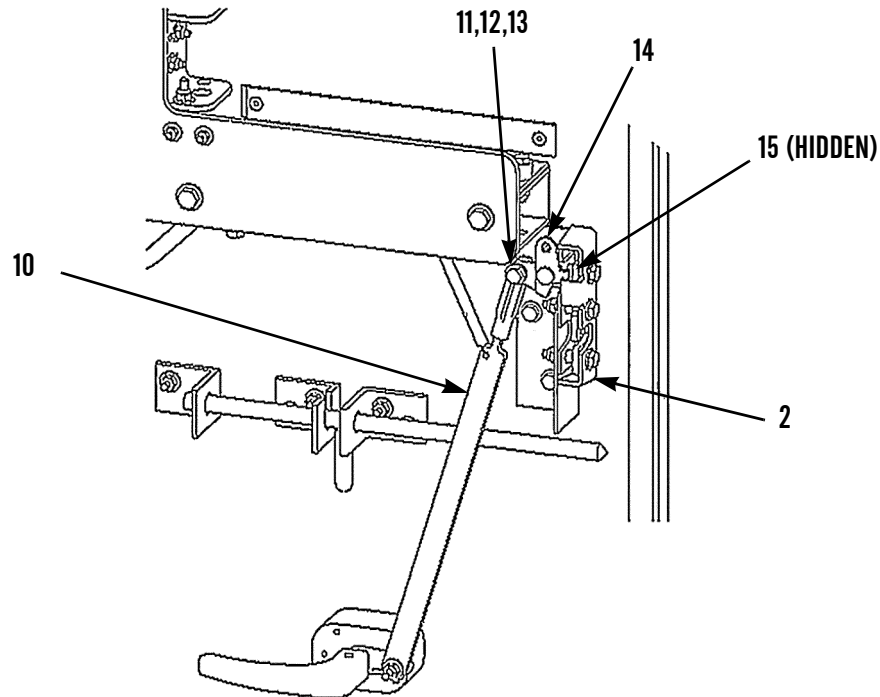

417-031

NOTE

Slight downward pressure on door handle should release latch and open door.

11. Repeat procedure if door does not open when slight downward pressure is applied to handle.

END OF WORK PACKAGE

DOOR LATCH ADJUSTMENT - MODEL B

0016 01

THIS WORK PACKAGE COVERS

Adjustment

INITIAL SETUP

Maintenance Level

Unit

Tools and Special Tools

Tool Kit, General Mechanic's (Item 13, WP 0034 00)

Materials/Parts

Rag, Wiping (Item 7, WP 0035 00)

Equipment Conditions

Vehicle parked on level ground (TM 9-2320-279-10)

Parking/Emergency Brake applied (TM 9-2320-279-10)

Engine off (TM 9-2320-279-10)

If equipped, Battery Disconnect Switch in OFF position (TM 9-2320-279-10)

ADJUSTMENT**NOTE**

Correct forward alignment of latch has striker in center of latch.

1. From inside cab, slowly close door and observe latch (1) and striker contact points.
2. To adjust forward position of latch (1), remove shims (7) between latch (1) and door bracket (6).

NOTE

Adjust latch height to match height of striker pin.

3. To adjust latch (1) height, loosen three nuts (5) and move latch up or down to match height of striker pin.
4. Tighten three nuts (5) when latch (1) is in correct position.

NOTE

- If link rod is too short, door will unlatch too quickly.
 - If link rod is too long, door will not latch smoothly.
5. To adjust link rod (3), loosen two jamnuts (2) and turn link rod.
 6. Tighten two jamnuts (2) when link rod (3) is in correct position.
 7. Repeat procedure if door does not open when pressure is applied to door handle (4).

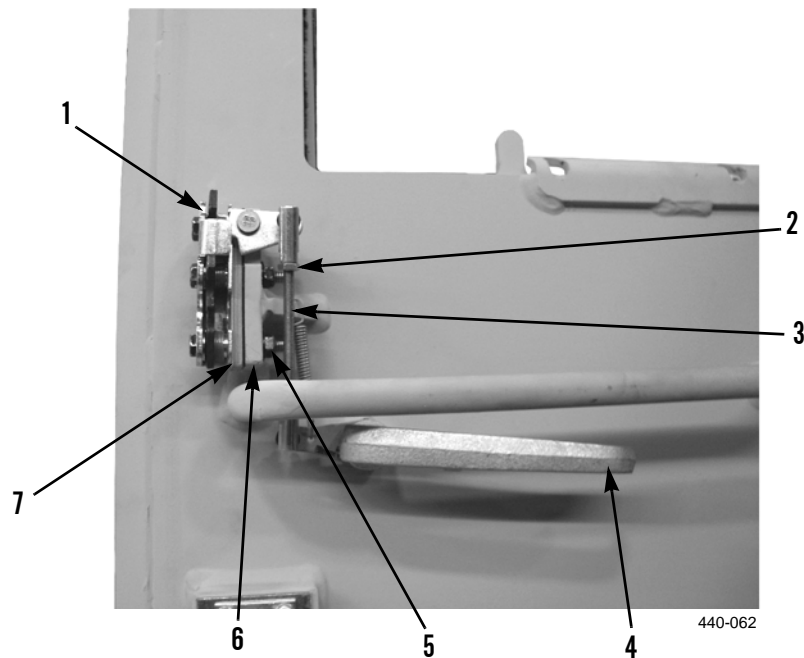
**END OF WORK PACKAGE**

WINDSHIELD BALLISTIC GLASS REPLACEMENT

0017 00

THIS WORK PACKAGE COVERSRemoval, Cleaning and Inspection, Installation

INITIAL SETUP**Maintenance Level**

Unit

Tools and Special Tools

Tool Kit, General Mechanic's (Item 13, WP 0034 00)

Shop Equipment, Common No. 1 (Item 10, WP 0034 00)

Dispenser, Sealant (Item 2, WP 0034 00)

Materials/Parts

Rag, Wiping (Item 7, WP 0035 00)

Sealant, Urethane (Item 8, WP 0035 00)

Locknut (22)

Lockwasher

References

WP 0010 00

WP 0011 00

Personnel Required

Two

Equipment Conditions

Vehicle parked on level ground (TM 9-2320-279-10)

Parking/Emergency Brake applied (TM 9-2320-279-10)

Engine off (TM 9-2320-279-10)

If equipped, Battery Disconnect Switch in OFF position (TM 9-2320-279-10)

NOTE

The following procedure is for left windshield ballistic glass. Right windshield ballistic glass is identical.

REMOVAL

1. Disconnect windshield washer hose from fitting on upper brush guard.
2. Remove nut (6), lockwasher (5), and wiper arm (1) from wiper extension (4).
3. Loosen setscrew (2) and remove wiper extension (4) from wiper shaft (3).

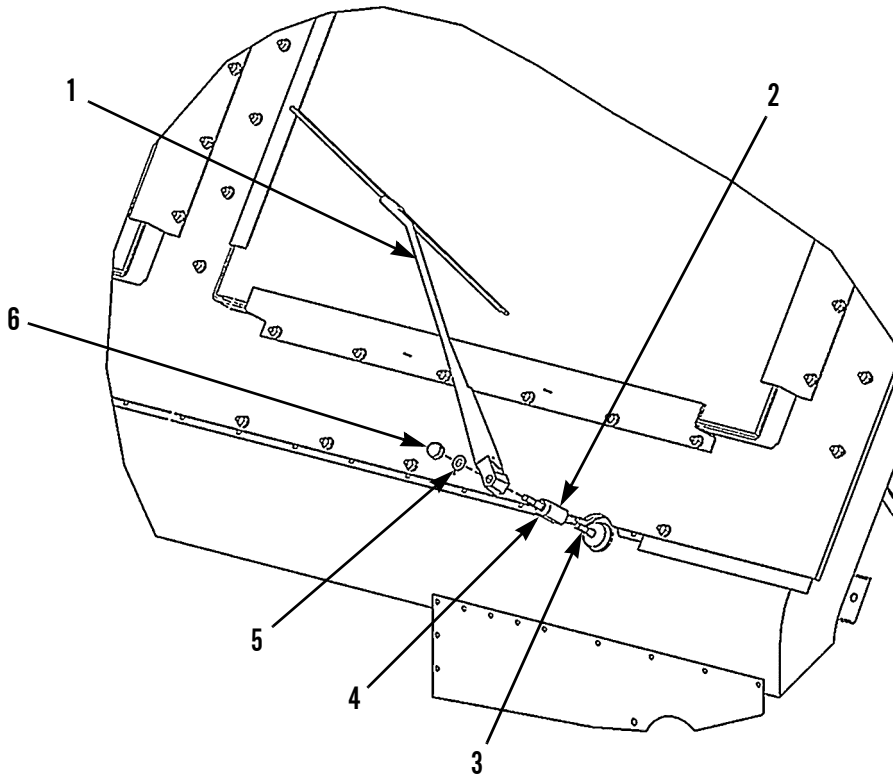

417-024

REMOVAL - CONTINUED

4. Loosen five bolts (14) on underside of roof bracket (11).
5. Remove six locknuts (12), washers (13), and roof bracket (11). Discard locknuts.
6. Remove 10 locknuts (15), washers (16), and two side windshield ballistic glass brackets (7) from windshield ballistic glass frame (20). Discard locknuts.
7. Remove six locknuts (8), washers (9), and top windshield ballistic glass bracket (10) from windshield ballistic glass (19). Discard locknuts.
8. Loosen six locknuts (17) on both bottom windshield ballistic glass brackets (18).

**WARNING**

Use caution when handling heavy parts. Provide adequate support and use assistance during procedure. Keep clear of heavy parts supported only by lifting device. Failure to follow this warning may cause injury or death to personnel.

NOTE

Windshield ballistic glass weighs 114 lb (52 kg).

9. With assistance, remove windshield ballistic glass (19) from lower windshield ballistic glass bracket (18).

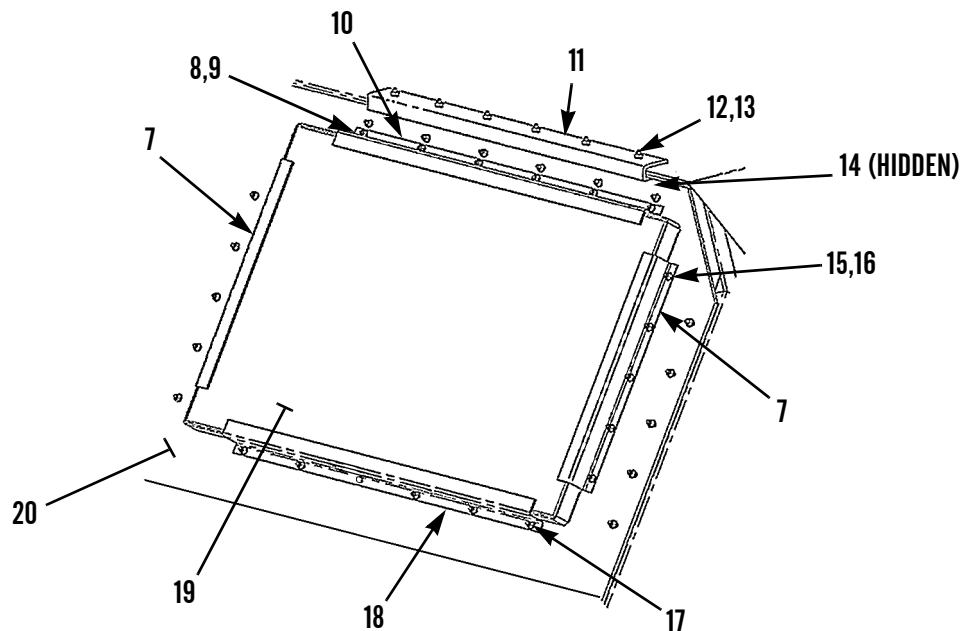

CLEANING AND INSPECTION

1. Clean and inspect all parts IAW *General Maintenance Instructions* (WP 0011 00).
2. Ensure all existing sealant is removed from windshield ballistic glass frame (20).

INSTALLATION**WARNING**

Use caution when using adhesives and sealants. Prolonged inhalation of vapors can cause lung irritation. Contact with skin can cause dermatitis. Wear gloves and safety goggles and use product in a well-ventilated area away from open flame. If ingested, keep individual calm and seek medical attention. **DO NOT** induce vomiting. If contact with skin or eyes is made, flush thoroughly with water. Dispose of cleanup rags IAW local policy and ordinances. Failure to follow this warning may cause injury to personnel.

1. Apply sealant between suds and opening of windshield ballistic glass frame (20).

**WARNING**

- Use caution when handling heavy parts. Provide adequate support and use assistance during procedure. Keep clear of heavy parts supported only by lifting device. Failure to follow this warning may cause injury or death to personnel.
- For proper threat protection, windshield ballistic glass must be correctly installed onto windshield ballistic glass frame. During installation, ensure that decal “INSTALL THIS SURFACE TOWARDS THREAT” is located on outside of cab. Improperly installed windshield ballistic glass will not protect occupants. Failure to follow this warning may cause injury or death to personnel.

NOTE

Windshield ballistic glass weighs 114 lb (52 kg).

2. With assistance, position windshield ballistic glass (19) in lower windshield ballistic glass bracket (18), with “INSTALL THIS SURFACE TOWARDS THREAT” decal facing outside of cab.
3. Install top windshield ballistic glass bracket (10) on windshield ballistic glass (19) with six washers (9) and new locknuts (8). **DO NOT** fully tighten locknuts.
4. Install two side windshield ballistic glass brackets (7) on windshield ballistic glass frame (20) with 10 washers (16), and new locknuts (15).

INSTALLATION - CONTINUED

5. Tighten locknuts (8, 15, and 17) to 108 lb-in. (12 Nm).

NOTE

Slide roof bracket rearward to ensure roof bracket is tight against front edge of roof.

6. Install roof bracket (11), six washers (13), and new locknuts (12) on roof.
7. Tighten five bolts (14) on underside of roof bracket (11).

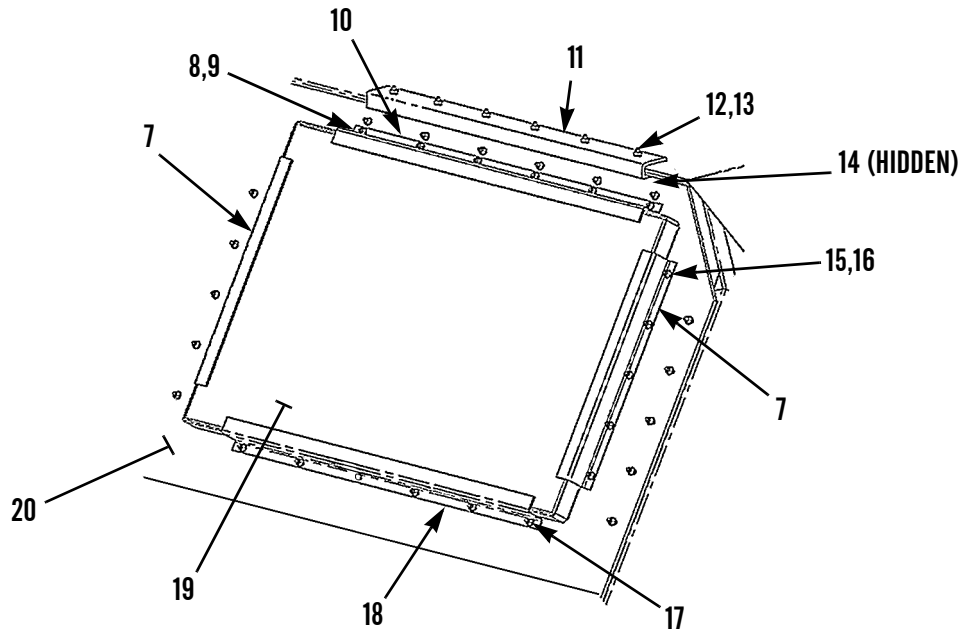

417-025

INSTALLATION - CONTINUED

8. Install wiper extension (4) fully onto wiper shaft (3) and tighten setscrew (2).
9. Install windshield wiper arm (1) on wiper extension (4) with new lockwasher (5) and nut (6).
10. Connect windshield washer hose to fitting on upper brush guard.
11. Remove decal and clean windshield ballistic glass (WP 0010 00).
12. Check windshield ballistic glass for leaks.

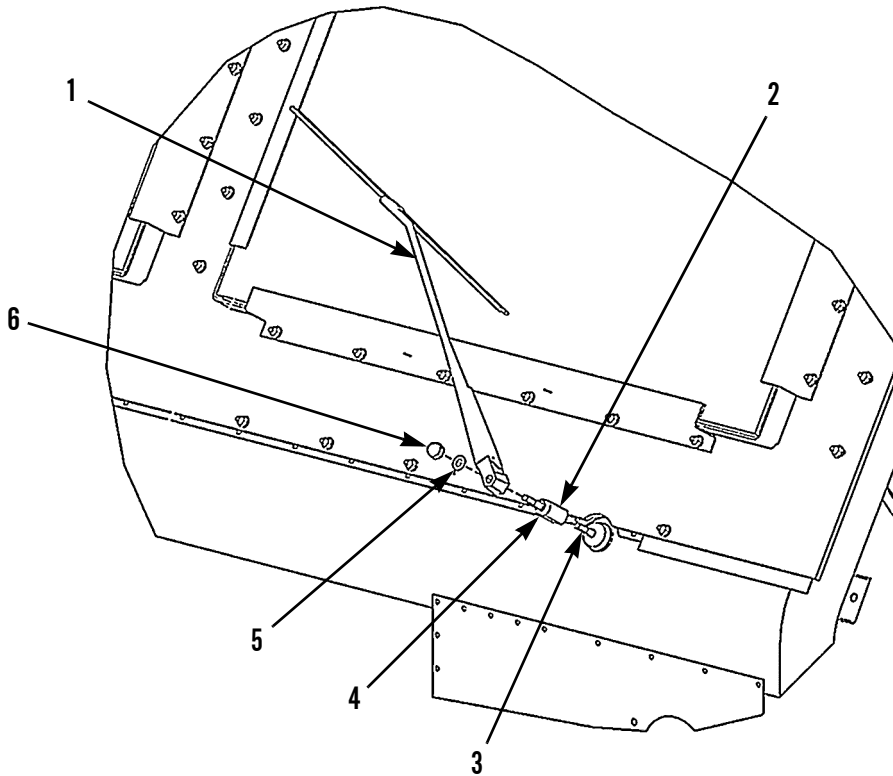

417-024

END OF WORK PACKAGE

UPPER BRUSH GUARD REPLACEMENT

0018 00**THIS WORK PACKAGE COVERS**Removal, Cleaning and Inspection, Installation

INITIAL SETUP**Maintenance Level**

Unit

Tools and Special Tools

Tool Kit, General Mechanic's (Item 13, WP 0034 00)

Shop Equipment, Common No. 1 (Item 10, WP 0034 00)

Sling (Item 11, WP 0034 00)

Stud, Threaded (2) (Item 12, WP 0034 00)

Lifting Device, 500-lb capacity

Materials/Parts

Adhesive, Thread (Item 1, WP 0035 00)

Rag, Wiping (Item 7, WP 0035 00)

Locknut (13)

References

WP 0011 00

Personnel Required

Two

Equipment Conditions

Vehicle parked on level ground (TM 9-2320-279-10)

Parking/Emergency Brake applied (TM 9-2320-279-10)

Engine off (TM 9-2320-279-10)

If equipped, Battery Disconnect Switch in OFF position (TM 9-2320-279-10)

Right and Left Headlight Assemblies removed (WP 0021 00)

REMOVAL**WARNING**

Use extreme caution when handling heavy parts. Provide adequate support and use assistance during procedure. Failure to follow this warning may cause injury to personnel.

NOTE

Upper brush guard cover weighs 27 lb (12 kg).

1. Disconnect blackout light (6) connector. Remove locknut (9), washer (10), bolt (7), washer (8), blackout light and bracket assembly (6). Discard locknut.
2. Remove three locknuts (3), washers (2), bolts (1), washers (4), and upper brush guard cover (5). Discard locknuts.
3. Remove eight locknuts (14), washers (13), bolts (12), and washers (11) from bottom row of upper brush guard (15). Discard locknuts.

**WARNING**

Use extreme caution when handling heavy parts. Provide adequate support and use assistance during procedure. Ensure that any lifting device used is in good condition and of suitable load capacity. Keep clear of heavy parts supported only by lifting device. Failure to follow this warning may cause injury or death to personnel.

NOTE

Upper brush guard weighs 131 lb (59 kg).

4. Attach sling and lifting device to upper brush guard (15).

NOTE

Leave two bolts (one on each end of upper brush guard) installed.

5. Remove four bolts (16) and washers (17) from top row of upper brush guard (15).
6. Install two threaded studs into two bolt holes where upper mounting bolts were removed.
7. While supporting upper brush guard (15) with sling and lifting device, remove remaining two bolts (16) and washers (17).
8. Remove upper brush guard (15) from vehicle and place on flat surface.
9. Remove sling and lifting device from upper brush guard (15).
10. Remove upper brush guard shim (18) from vehicle and place on flat surface.
11. Remove two threaded studs from upper brush guard mounting holes.

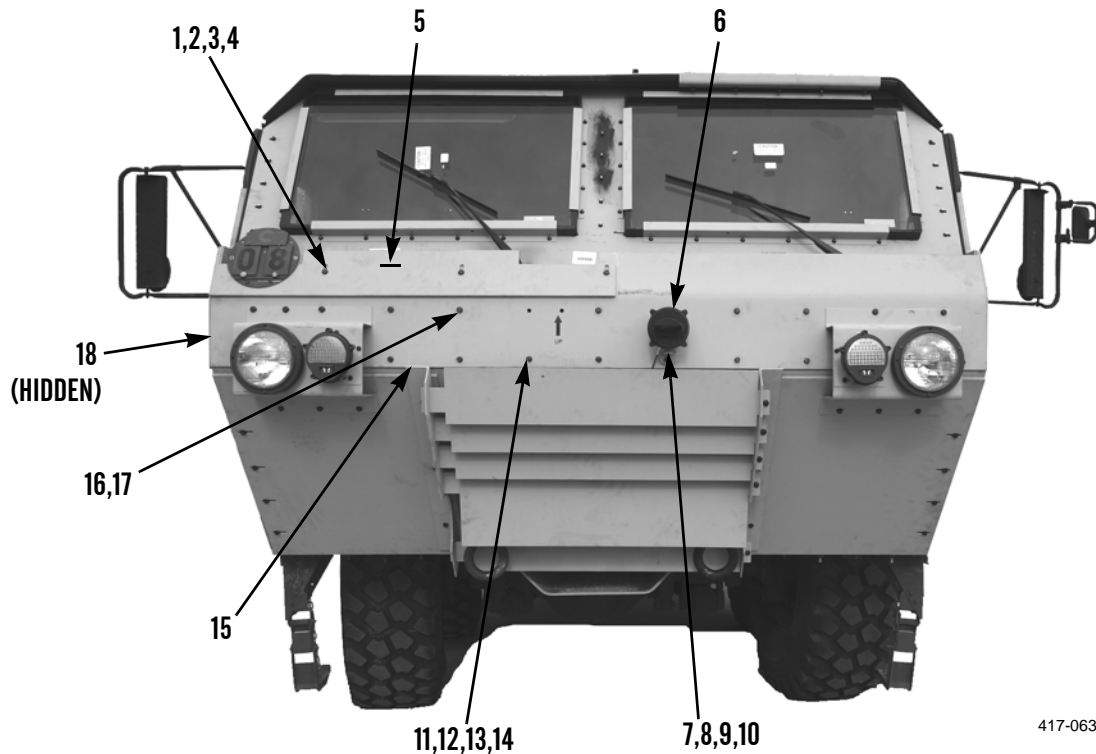
REMOVAL - CONTINUED

417-063

CLEANING AND INSPECTION

Clean and inspect all parts IAW *General Maintenance Instructions* (WP 0011 00).

INSTALLATION

1. Install two threaded studs into second threaded hole from each outside end of upper brush guard (15). Hand tighten studs.
2. Install upper brush guard shim (18) over threaded studs.

**WARNING**

Use extreme caution when handling heavy parts. Provide adequate support and use assistance during procedure. Ensure that any lifting device used is in good condition and of suitable load capacity. Keep clear of heavy parts supported only by lifting device. Failure to follow this warning may cause injury or death to personnel.

NOTE

Upper brush guard weighs 131 lb (59 kg).

3. Attach sling and lifting device to upper brush guard (15).

INSTALLATION - CONTINUED

4. Use lifting device to position upper brush guard (15) over threaded studs, upper brush guard shim (18), and lower brush guard, with up arrow ↑↑ facing installer.

**WARNING**

Use caution when using adhesives and sealants. Prolonged inhalation of vapors can cause lung irritation. Contact with skin can cause dermatitis. Wear gloves and safety goggles and use product in a well-ventilated area away from open flame. If ingested, keep individual calm and seek medical attention. **DO NOT** induce vomiting. If contact with skin or eyes is made, flush thoroughly with water. Dispose of cleanup rags IAW local policy and ordinances. Failure to follow this warning may cause injury to personnel.

NOTE

- Do not install bolts in headlight bracket holes.
 - Threaded studs are removed as bolts are installed.
5. Apply thread adhesive to bolts (16). Install six washers (17) and bolts (16) in top row of upper brush guard (15). Hand tighten bolts.
 6. Check alignment of upper brush guard (15). Adjust as necessary.
 7. Install eight washers (11), bolts (12), washers (13), and new locknuts (14) in bottom row of upper brush guard (15). Tighten locknuts to 35 lb-ft (47 Nm).
 8. Tighten four bolts (16) in upper brush guard (15) to 35 lb-ft (47 Nm).

**WARNING**

Use extreme caution when handling heavy parts. Provide adequate support and use assistance during procedure. Failure to follow this warning may cause injury to personnel.

NOTE

Upper brush guard cover weighs 26 lb (12 kg).

9. Install upper brush guard cover (5) with three washers (4), bolts (1), washers (2), and new locknuts (3).
10. Install blackout light and bracket assembly (6), washer (8), bolt (7), washer (10) and new locknut (9).

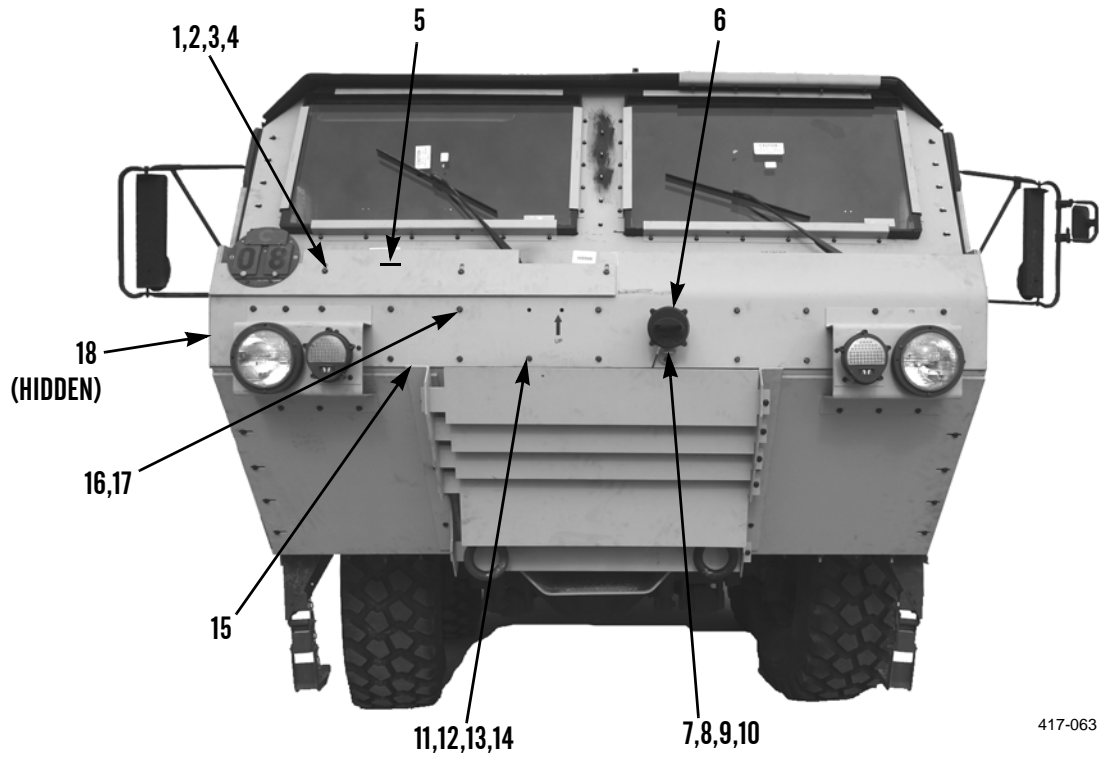
INSTALLATION - CONTINUED

11. Connect blackout light (6) electrical connector.
12. Install right and left headlight assemblies (WP 0021 00).

END OF WORK PACKAGE

LOWER BRUSH GUARD REPLACEMENT

0019 00

THIS WORK PACKAGE COVERS

Removal, Cleaning and Inspection, Installation

INITIAL SETUP

Maintenance Level

Unit

Personnel Required

Three

Tools and Special Tools

- Tool Kit, General Mechanic's (Item 13, WP 0034 00)
- Shop Equipment, Common No. 1 (Item 10, WP 0034 00)
- Link, Lifting (2) (Item 8, WP 0034 00)
- Sling (Item 11, WP 0034 00)
- Lifting Device, 500-lb capacity

Equipment Conditions

- Vehicle parked on level ground (TM 9-2320-279-10)
- Parking/Emergency Brake applied (TM 9-2320-279-10)
- Engine off (TM 9-2320-279-10)
- If equipped, Battery Disconnect Switch in OFF position (TM 9-2320-279-10)
- Headlights and Composite Lights removed (WP 0021 00)
- Blackout Drive Light removed (WP 0022 00)
- Louvered Grille removed (WP 0020 00)
- Upper Brush Guard removed (WP 0018 00)

Materials/Parts

Locknut (14)

References

WP 0011 00

LOWER BRUSH GUARD REPLACEMENT - CONTINUED**0019 00****REMOVAL**

1. Remove six locknuts (1), washers (2), bolts (3), and washers (4) from front edge of both side blast shields (9). Discard locknuts.
2. Remove eight locknuts (5), washers (6), bolts (7), and washers (8) from front edge of both side blast shields (9). Discard locknuts.

**WARNING**

Use extreme caution when handling heavy parts. Provide adequate support and use assistance during procedure. Ensure that any lifting device used is in good condition and of suitable load capacity. Keep clear of heavy parts supported only by lifting device. Failure to follow this warning may cause injury or death to personnel.

NOTE

Lower brush guard weighs 219 lb (99 kg).

3. Attach two lifting links, sling, and lifting device to top edge of lower brush guard (13).

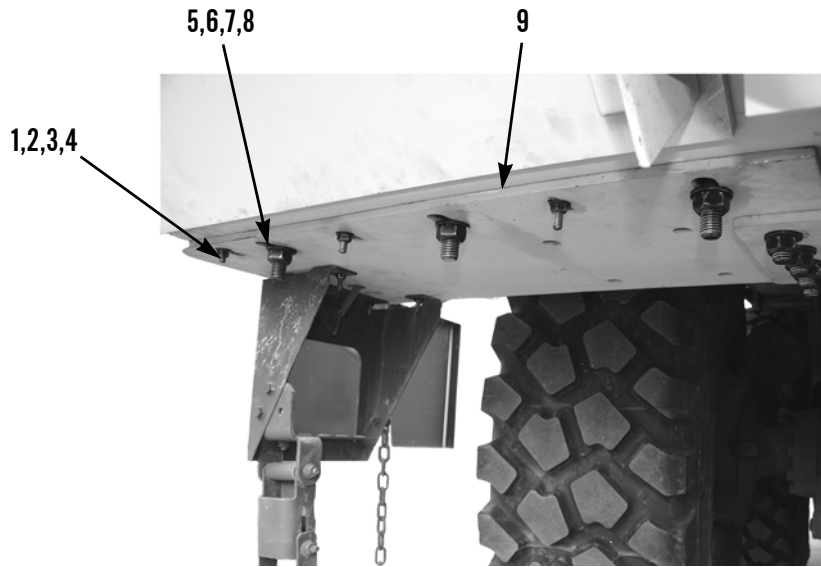

417-065

LOWER BRUSH GUARD REPLACEMENT - CONTINUED

0019 00

REMOVAL - CONTINUED

4. With assistance, remove four bolts (10), washers (11), and left-side armor panel (12) from lower brush guard (13).
5. With assistance, remove four bolts (15), washers (16), and right-side armor panel (14) from lower brush guard (13).
6. Push two wiring harnesses (17) through holes in lower brush guard (13).
7. Using lifting device, remove lower brush guard (13) from vehicle and place on flat surface.
8. Remove lifting device, sling, and two lifting links from lower brush guard (13).

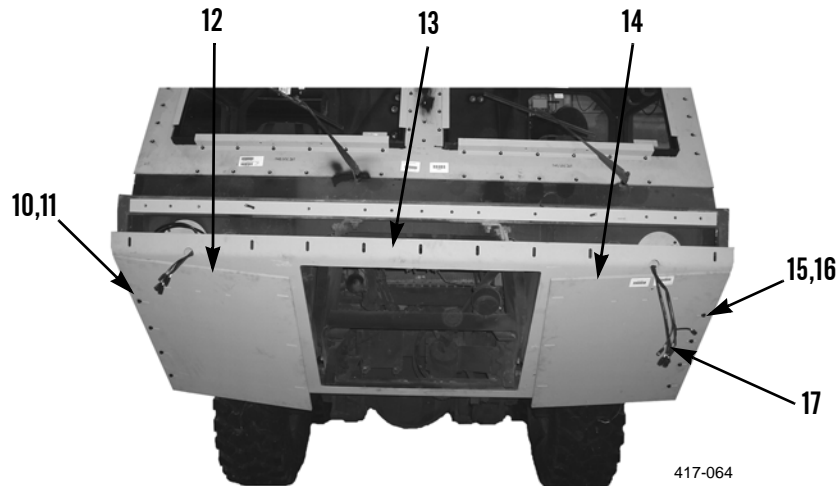
**CLEANING AND INSPECTION**

Clean and inspect all parts IAW *General Maintenance Instructions* (WP 0011 00).

INSTALLATION**WARNING**

Use extreme caution when handling heavy parts. Provide adequate support and use assistance during procedure. Ensure that any lifting device used is in good condition and of suitable load capacity. Keep clear of heavy parts supported only by lifting device. Failure to follow this warning may cause injury or death to personnel.

NOTE

Lower brush guard weighs 219 lb (99 kg).

1. Attach two lifting links, sling, and lifting device to top edge of lower brush guard (13). Position lower brush guard over grille area at front of vehicle.
2. Feed two wiring harnesses (17) through holes in lower brush guard (13).
3. With assistance, position right-side armor panel (14) and install four washers (16) and bolts (15). Hand tighten bolts.
4. With assistance, position left-side armor panel (12) and install four washers (11) and bolts (10). Hand tighten bolts.
5. Install eight bolts (5), washers (6), washers (7), and new locknuts (8) to front edge of both side blast shields (9). Tighten bolts to 35 lb-ft (47 Nm).
6. Install six washers (2), bolts (1), washers (3), and new locknuts (4) to front edge of both side blast shields (9).
7. Remove lifting device, sling, and two lifting links from lower brush guard (13).

LOWER BRUSH GUARD REPLACEMENT - CONTINUED

0019 00

INSTALLATION - CONTINUED

8. Install louvered grille (WP 0020 00).
9. Install upper brush guard (WP 0018 00).
10. Install headlights, composite lights and blackout drive light (WP 0022 00).
11. Install headlights and composite lights (WP 0021 00).

END OF WORK PACKAGE

LOUVERED GRILLE REPLACEMENT

0020 00

THIS WORK PACKAGE COVERS

Removal, Cleaning and Inspection, Installation

INITIAL SETUP

Maintenance Level

Unit

Personnel Required

Two

Tools and Special Tools

Tool Kit, General Mechanic's (Item 13, WP 0034 00)

Shop Equipment, Common No. 1 (Item 10, WP 0034 00)

Equipment Conditions

Vehicle parked on level ground (TM 9-2320-279-10)

Parking/Emergency Brake applied (TM 9-2320-279-10)

Materials/Parts

Locknut (11)

Engine off (TM 9-2320-279-10)

References

WP 0011 00

If equipped, Battery Disconnect Switch in OFF position (TM 9-2320-279-10)

LOUVERED GRILLE REPLACEMENT - CONTINUED**0020 00****REMOVAL**

1. Remove five locknuts (5), washers (4), bolts (2), and washers (3) from left end of five louvered grille panels (1). Discard locknuts.

**WARNING**

Use extreme caution when handling heavy parts. Provide adequate support and use assistance during procedure. Failure to follow this warning may cause injury to personnel.

NOTE

- When removing louvered grille panels, work from top to bottom.
 - Remove louvered grille panels by sliding each panel toward right side of vehicle.
 - Each louvered grille panel weighs approximately 30 lb (14 kg).
2. Remove five louvered grille panels (1) from right and left louvered grille brackets (10 and 11).
 3. Remove six locknuts (9), washers (8), bolts (6), washers (7), and two louvered grille brackets (10 and 11) from lower brush guard. Discard locknuts.

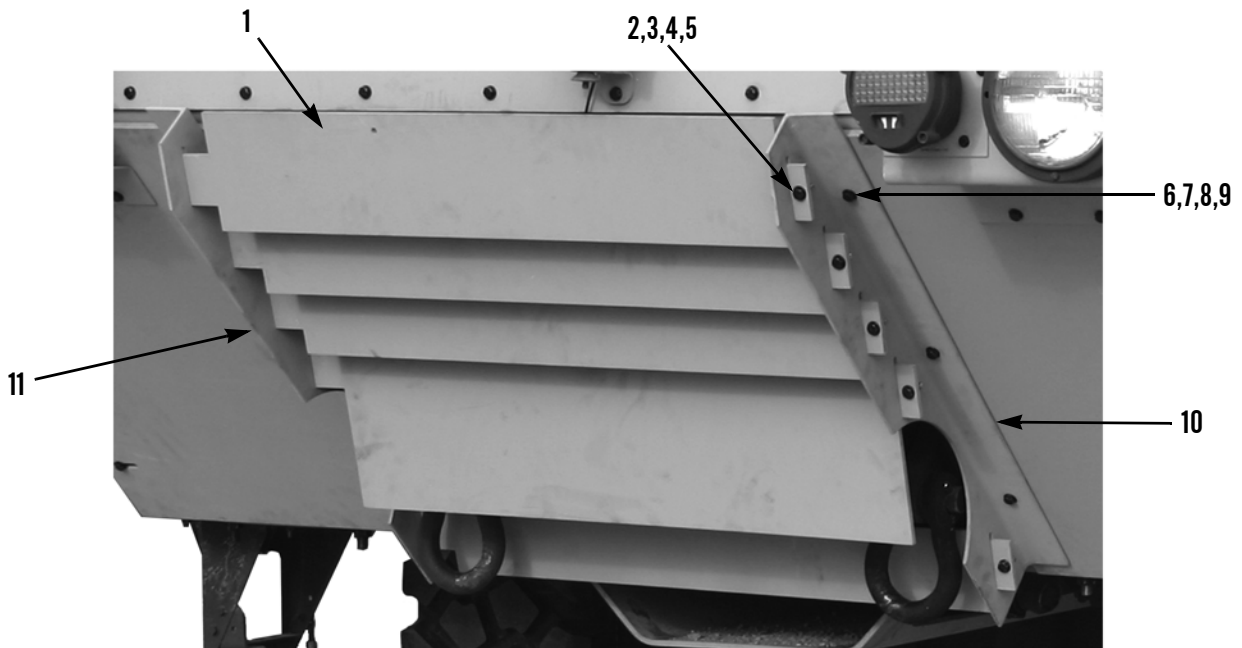

417-066

CLEANING AND INSPECTION

Clean and inspect all parts IAW *General Maintenance Instructions* (WP 0011 00).

INSTALLATION**NOTE**

- Louvered grille brackets are marked “THIS SIDE TOWARD RADIATOR” and “THIS END UP.”
 - Ensure bracket orientation is correct before installation.
1. Install two louvered grille brackets (11 and 10) on lower brush guard with six washers (7), bolts (6), washers (8), and new locknuts (9). Tighten locknuts to 35 lb-ft (47 Nm).

**WARNING**

Use extreme caution when handling heavy parts. Provide adequate support and use assistance during procedure. Failure to follow this warning may cause injury to personnel.

NOTE

- When installing louvered grille panels, first insert end without bolt hole into right louvered grille bracket.
 - When installing louvered grille panels, work from bottom to top.
 - Each louvered grille panel weighs approximately 30 lb (14 kg).
2. Install five louvered grille panels (1) on louvered grille brackets (10 and 11).
 3. Install five washers (3), bolts (2), washers (4), and new locknuts (5) on left end of louvered grille panels (1). Tighten locknuts to 35 lb-ft (47 Nm).

END OF WORK PACKAGE

HEADLIGHT AND COMPOSITE LIGHT REPLACEMENT

0021 00**THIS WORK PACKAGE COVERS**

Removal: Configuration A, Configuration B; Cleaning and Inspection; Installation: Configuration A, Configuration B

INITIAL SETUP**Maintenance Level**

Unit

References

WP 0011 00

Tools and Special Tools

Tool Kit, General Mechanic's (Item 13, WP 0034 00)

Equipment Conditions

Vehicle parked on level ground (TM 9-2320-279-10)

Parking/Emergency Brake applied (TM 9-2320-279-10)

Engine off (TM 9-2320-279-10)

If equipped, Battery Disconnect Switch in OFF position (TM 9-2320-279-10)

Materials/Parts

Tag, Marker (Item 10, WP 0035 00)

Locknut (11)

NOTE

- Configuration A headlight assemblies have an LED unit inside the front composite light, mounted inboard of the headlight.
- Configuration B headlight assemblies have an incandescent bulb inside the front composite light, mounted inboard of the headlight.

REMOVAL (CONFIGURATION A)**NOTE**

- The following procedure covers both left and right headlight assemblies (Configuration A).
- Left headlight assembly (Configuration A) is illustrated.

1. Tag and disconnect jumper harness connectors (5) from headlight (11) and front composite light (12).
2. Remove three locknuts (6), washers (7), and headlight (11) from headlight bracket (10). Discard locknuts.
3. Remove five locknuts (4), washers (3), bolts (13), washers (14), and front composite light (12) from headlight bracket (10). Discard locknuts.
4. Remove two bolts (1) and washers (2) from top of headlight bracket (10).
5. Remove three locknuts (9) and washers (8) from bottom of headlight bracket (10). Discard locknuts.
6. Remove headlight bracket (10) from lower brush guard.

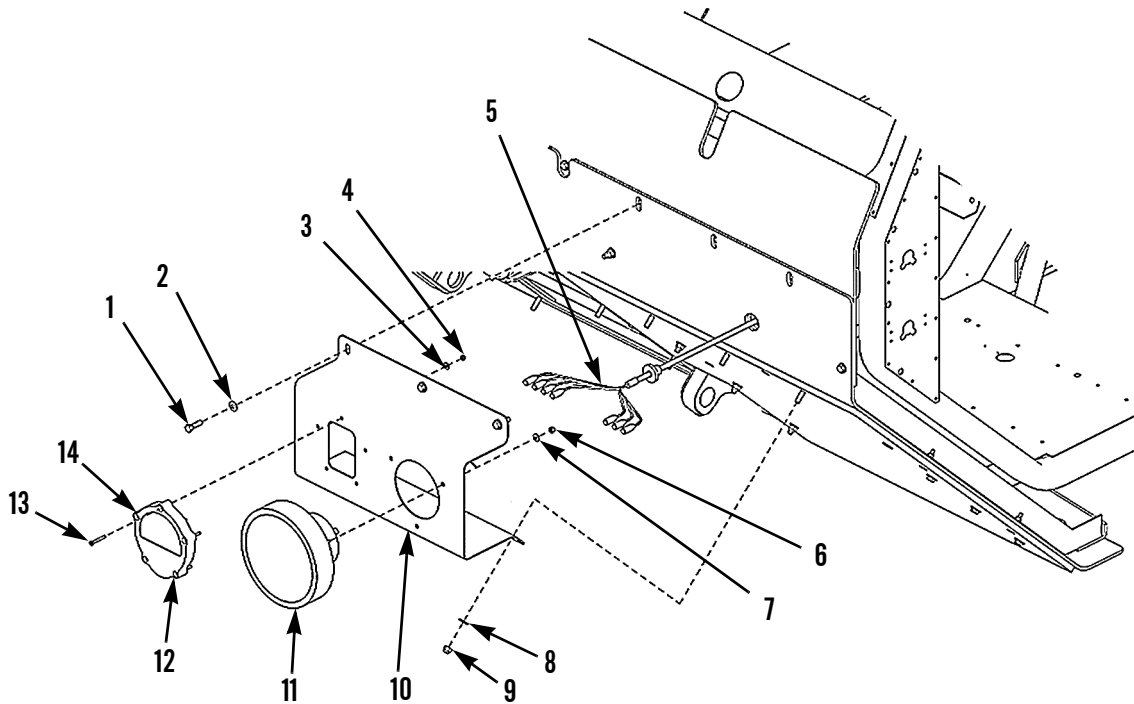

417-132

REMOVAL (CONFIGURATION B)**NOTE**

- The following procedure covers both left and right headlight assemblies (Configuration B).
- Left headlight assembly (Configuration B) is illustrated.

1. Tag and disconnect jumper harness connectors (5) from headlight (11) and front composite light (13).
2. Remove three locknuts (6), washers (7), and headlight (11) from headlight bracket (10). Discard locknuts.
3. Remove two bolts (17), washers (16), and front composite light (13) from headlight adapter (12).
4. Remove five locknuts (4), washers (3), bolts (14), washers (15), and headlight adapter (12) from headlight bracket (10). Discard locknuts.
5. Remove two bolts (1) and washers (2) from top of headlight bracket (10).
6. Remove three locknuts (9) and washers (8) from bottom of headlight bracket (10). Discard locknuts.
7. Remove headlight bracket (10) from lower brush guard.

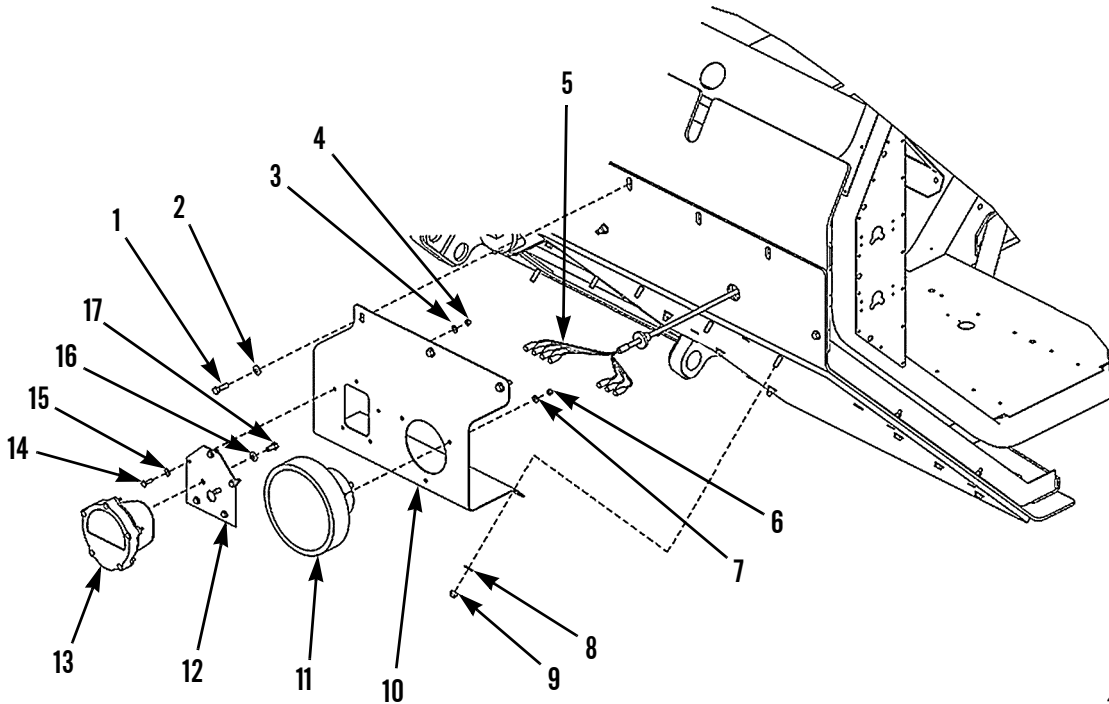

417-133

CLEANING AND INSPECTION

Clean and inspect all parts IAW *General Maintenance Instructions* (WP 0011 00).

INSTALLATION (CONFIGURATION B)**NOTE**

- The following procedure covers both left and right headlight assemblies (Configuration B).
- Left headlight assembly (Configuration B) is illustrated.

1. Position headlight bracket (10) over mounting holes on lower brush guard.
2. Install two washers (2) and bolts (1) in top of headlight bracket (10).
3. Install three washers (8) and new locknuts (9) in bottom of headlight bracket (10).
4. Install headlight adapter (12), five washers (15), bolts (14), washers (3), and new locknuts (4) in headlight bracket (10).
5. Install front composite light (13), two washers (16), and bolts (17) in headlight adapter (12).
6. Install headlight (11), three washers (7) and new locknuts (6) in headlight bracket (10).
7. Connect jumper harness connectors (5) to headlight (11) and front composite light (13).

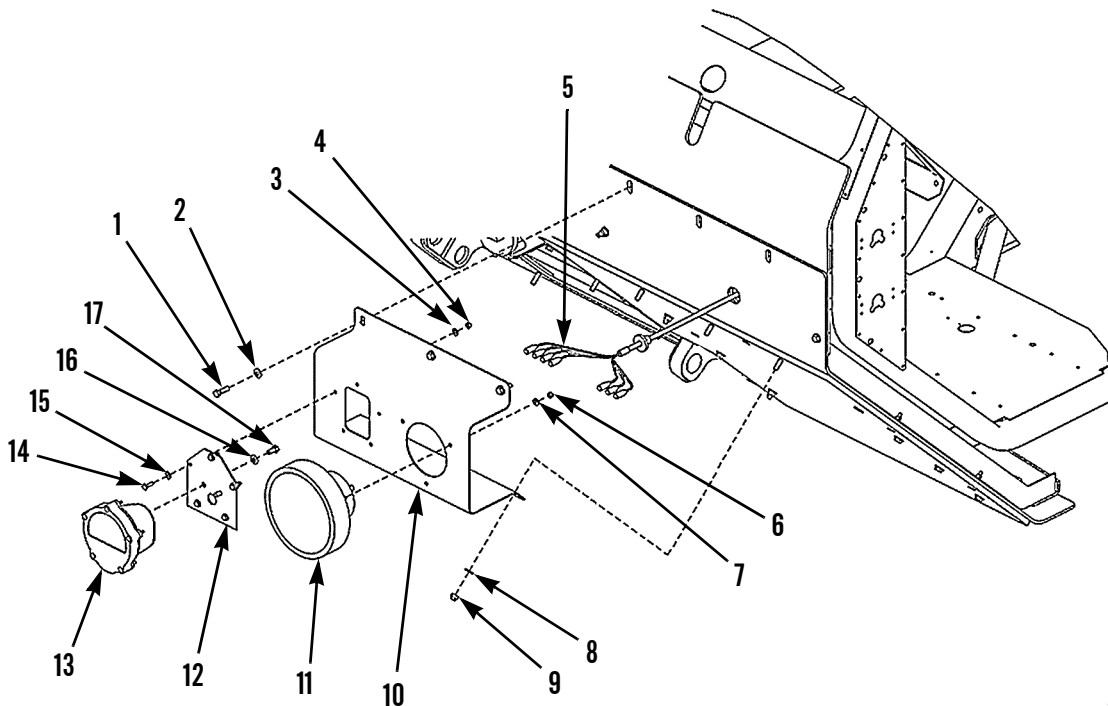

417-133

8. If equipped, turn battery disconnect switch to ON position (TM 9-2320-364-10).
9. Check operation of headlights and front composite lights (TM 9-2320-364-10).

INSTALLATION (CONFIGURATION A)**NOTE**

- The following procedure covers both left and right headlight assemblies (Configuration A).
- Left headlight assembly (Configuration A) is illustrated.

1. Position headlight bracket (10) over mounting holes on lower brush guard.
2. Install two washers (2) and bolts (1) in top of headlight bracket (10).
3. Install three washers (8) and new locknuts (9) in bottom of headlight bracket (10).
4. Install front composite light (12), five washers (14), bolts (13), washers (3), and new locknuts (4) in headlight bracket (10).
5. Install headlight (11), three washers (7) and new locknuts (6) on headlight bracket (10).
6. Connect jumper harness connectors (5) to headlight (11) and front composite light (12).

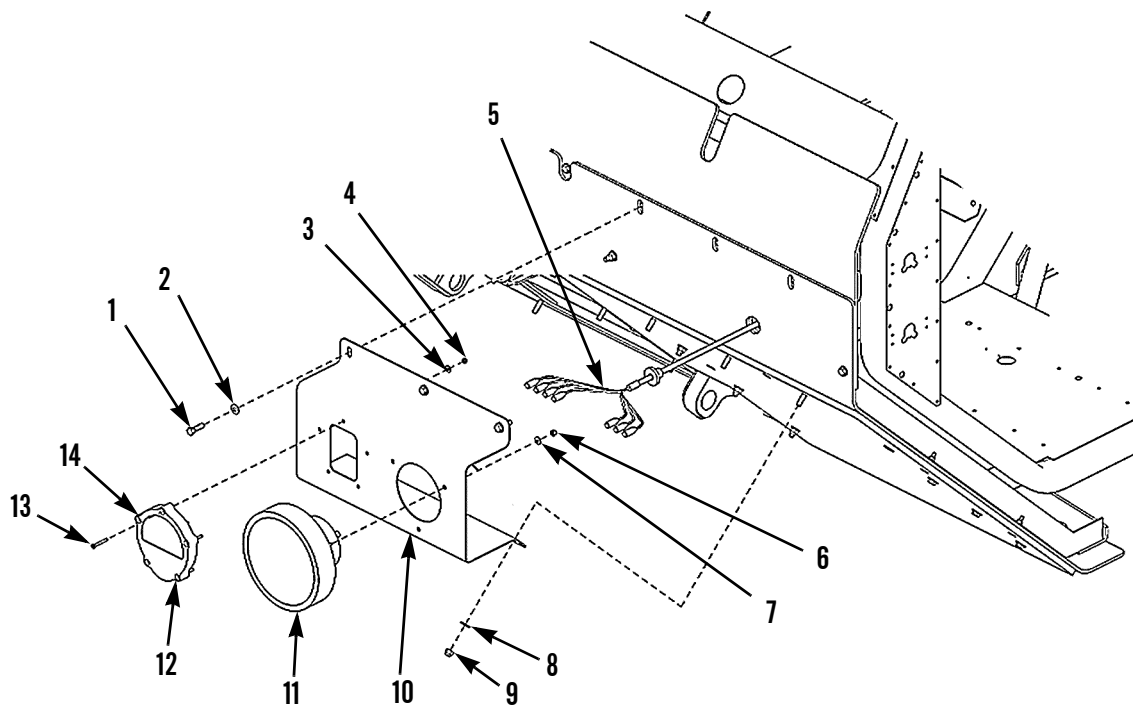

417-132

7. If equipped, turn battery disconnect switch to ON position (TM 9-2320-364-10).
8. Check operation of headlights and front composite lights (TM 9-2320-364-10).

END OF WORK PACKAGE

BLACKOUT DRIVE LIGHT REPLACEMENT

0022 00

THIS WORK PACKAGE COVERS

Removal, Cleaning and Inspection, Installation

INITIAL SETUP

Maintenance Level

Unit

Tools and Special Tools

Tool Kit, General Mechanic's (Item 13, WP 0034 00)

Materials/Parts

Locknut

References

WP 0011 00

Equipment Conditions

Vehicle parked on level ground (TM 9-2320-279-10)

Parking/Emergency Brake applied (TM 9-2320-279-10)

Engine off (TM 9-2320-279-10)

If equipped, Battery Disconnect Switch in OFF position (TM 9-2320-279-10)

BLACKOUT DRIVE LIGHT REPLACEMENT - CONTINUED

0022 00

REMOVAL

1. Disconnect blackout drive electrical connector (4).
2. Remove locknut (5), washer (6), bolt (3), washer (2), and blackout drive light (1) from bracket (7). Discard locknut.

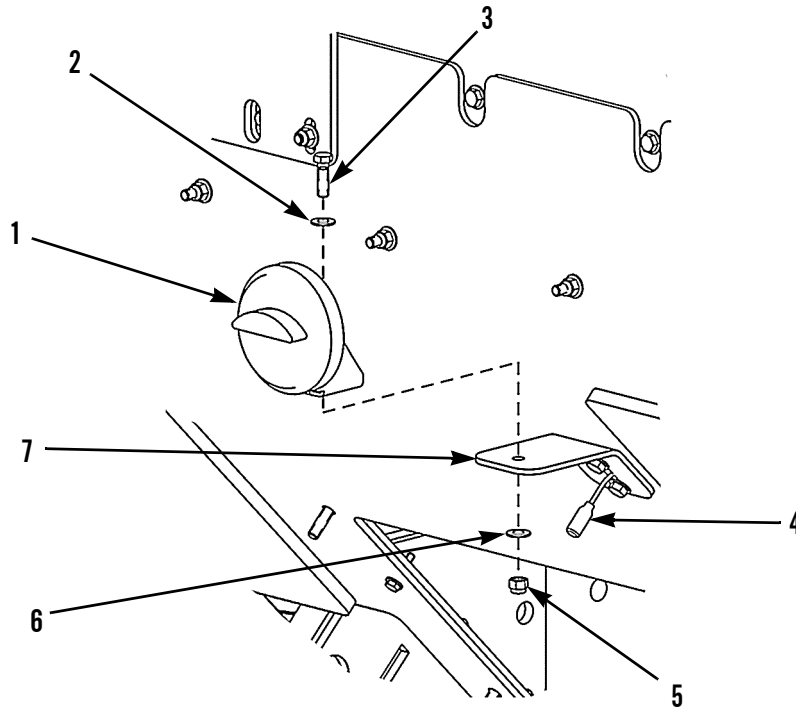

417-136

CLEANING AND INSPECTION

Clean and inspect all parts IAW *General Maintenance Instructions* (WP 0011 00).

INSTALLATION

1. Install blackout drive light (1), washer (2), bolt (3), washer (6), and new locknut (5) on bracket (7).
2. Connect blackout drive electrical connector (4).
3. If equipped, turn battery disconnect switch to ON position (TM 9-2320-364-10).
4. Check operation of blackout drive light (TM 9-2320-364-10).

END OF WORK PACKAGE

ESCAPE HATCH ASSEMBLY MAINTENANCE

0023 00

THIS WORK PACKAGE COVERS

Removal, Disassembly, Cleaning and Inspection, Assembly, Installation

INITIAL SETUP

Maintenance Level

Unit

Personnel Required

Two

Tools and Special Tools

Tool Kit, General Mechanic's (Item 13, WP 0034 00)

Equipment Conditions

Vehicle parked on level ground (TM 9-2320-279-10)

Materials/Parts

Locknuts (12)

Parking/Emergency Brake applied (TM 9-2320-279-10)

References

WP 0004 00

Engine off (TM 9-2320-279-10)

WP 0011 00

If equipped, Battery Disconnect Switch in OFF position (TM 9-2320-279-10)

REMOVAL**WARNING**

Use extreme caution when handling heavy parts. Provide adequate support and use assistance during procedure. Failure to follow this warning may cause injury to personnel.

NOTE

Escape hatch weighs 61 lb (28 kg).

Using assistance, unlatch escape hatch (7) and remove from roof (WP 0004 00).

DISASSEMBLY

1. Remove eight bolts (1), washers (2), and four draw latch T-handles (8) from underside of escape hatch (7).
2. Remove four bolts (3), eight washers (4), and locknuts (5) from two escape hatch handles (6).

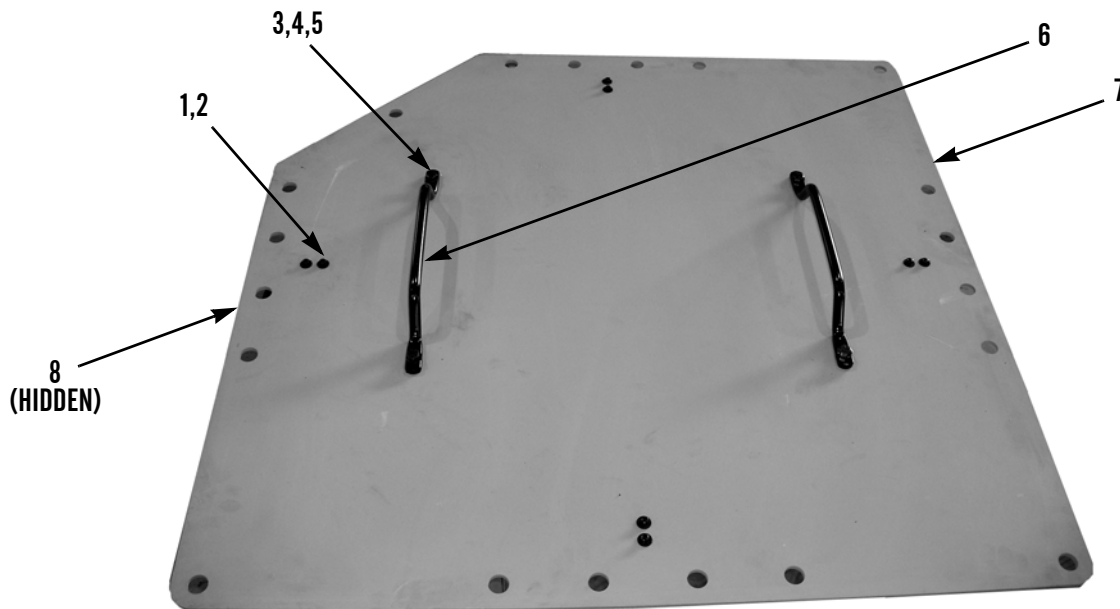

417-068

DISASSEMBLY - CONTINUED

3. Remove eight locknuts (9), washers (10), bolts (13), washers (14), and four escape hatch brackets (11) from roof. Discard locknuts.
4. Remove four bolts (16), washers (15), and keeper pins (12) from four escape hatch brackets (11).

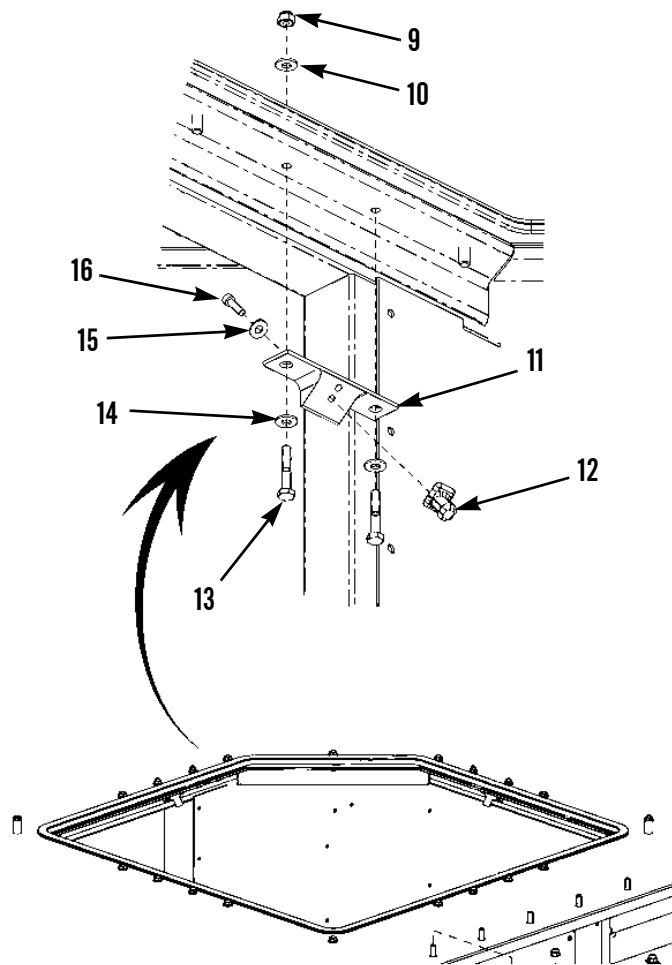

417-018

CLEANING AND INSPECTION

Clean and inspect all parts IAW *General Maintenance Instructions* (WP 0011 00).

ASSEMBLY**CAUTION**

Do not overtighten draw latch component mounting hardware, or damage to draw latch components may result.

1. Install four keeper pins (12) on four escape hatch brackets (11) with four washers (15) and bolts (16). Tighten bolts to 36 lb-in. (4 Nm).
2. Install four escape hatch brackets (11) to roof with eight washers (14), bolts (13), washers (10), and new locknuts (9).

ESCAPE HATCH ASSEMBLY MAINTENANCE - CONTINUED**0023 00****ASSEMBLY - CONTINUED**

3. Install two escape hatch handles (6) on top of escape hatch (7) with four bolts (3), eight washers (4), and four new lock-nuts (5).
4. Install four draw latch T-handles (8) on underside of escape hatch (7) with eight washers (2) and bolts (1).

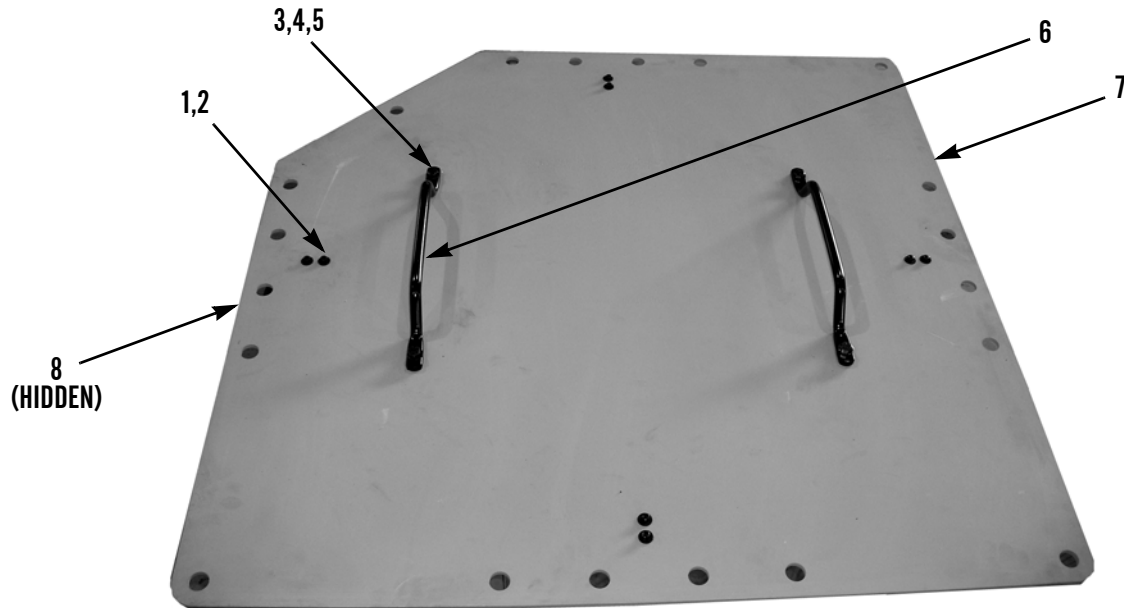

417-068

INSTALLATION**WARNING**

Use extreme caution when handling heavy parts. Provide adequate support and use assistance during procedure. Failure to follow this warning may cause injury to personnel.

NOTE

Escape hatch weighs 61 lb (28 kg).

Using assistance, install escape hatch (7) on roof and latch (WP 0004 00).

END OF WORK PACKAGE

ROOF ARMOR REPLACEMENT

0024 00**THIS WORK PACKAGE COVERS**Removal, Cleaning and Inspection, Installation

INITIAL SETUP**Maintenance Level**

Unit

Tools and Special Tools

Tool Kit, General Mechanic's (Item 13, WP 0034 00)

Shop Equipment, Common No. 1 (Item 10, WP 0034 00)

Sling (Item 11, WP 0034 00)

Lifting Device, 500-lb capacity

Materials/Parts

Adhesive, Thread (Item 1, WP 0035 00)

Rag, Wiping (Item 7, WP 0035 00)

Sealing Compound, Urethane (Item 8, WP 0035 00)

Locknut (18)

Lockwasher (10)

References

WP 0011 00

Personnel Required

Two

Equipment Conditions

Vehicle parked on level ground (TM 9-2320-279-10)

Parking/Emergency Brake applied (TM 9-2320-279-10)

Engine off (TM 9-2320-279-10)

If equipped, Battery Disconnect Switch in OFF position (TM 9-2320-279-10)

If equipped, C4ISR Brackets removed (WP 0040 00)

Escape Hatch removed (WP 0023 00)

ROOF ARMOR REPLACEMENT - CONTINUED

0024 00**REMOVAL**

1. Loosen five bolts (5) from underside of left-front roof armor bracket (4).
2. Remove six locknuts (2), washers (3), and left-front roof armor bracket (4). Discard FOUR locknuts.

NOTE

Loosely reinstalling locknuts secures left-front stud plate to roof armor during removal procedure.

3. Loosely reinstall two locknuts (2) on left-front stud plate (1).
4. Remove four locknuts (15) and washers (16) from left-rear roof armor bracket (20). Discard locknuts.
5. Remove four locknuts (17), washers (18), bolts (19), left-rear roof armor bracket (20), and spacer plate (21). Discard TWO locknuts.

NOTE

Loosely reinstalling two locknuts secures left-rear stud plate to roof armor during removal procedure.

6. Loosely reinstall two locknuts (15) on left-rear stud plate (22).
7. Remove 10 bolts (7), lockwashers (8), and washers (9) from roof armor (6). Discard lockwashers.
8. Remove two bolts (10) and spacers (11) from opposite corners of escape hatch opening.

**WARNING**

Use extreme caution when handling heavy parts. Provide adequate support and use assistance during procedure. Ensure that any lifting device used is in good condition and of suitable load capacity. Keep clear of heavy parts supported only by lifting device. Failure to follow this warning may cause injury or death to personnel.

NOTE

Roof armor weighs 166 lb (75 kg).

9. Attach sling and lifting device to two lifting eyes (13) in center holes of roof armor (6).
10. Using lifting device, remove roof armor (6) from cab roof and place on flat surface.
11. Remove two locknuts (2) and left-front stud plate (1). Discard locknuts.
12. Remove two locknuts (15) and left-rear stud plate (22). Discard locknuts.
13. If damaged, remove escape hatch seal (12) from roof armor (6).
14. Remove four locknuts (24), washers (25), bolts (26), washers (27) and two storage brackets (23) from roof armor (6). Discard locknuts.
15. Remove two lifting eyes (13) and stud plate (14) from roof armor (6).

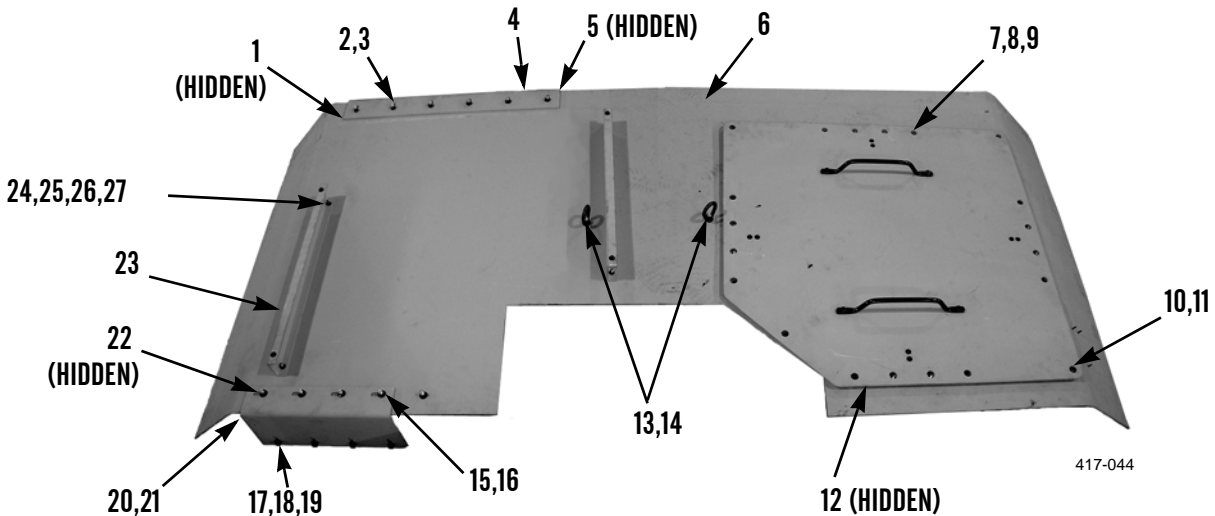
REMOVAL - CONTINUED**CLEANING AND INSPECTION**

Clean and inspect all parts IAW *General Maintenance Instructions* (WP 0011 00).

INSTALLATION

1. Install two storage brackets (23), four washers (27), bolts (26), washers (25), and new locknuts (24) on roof armor (6).
2. If removed, install escape hatch seal (12) around escape hatch opening of roof armor (6).
3. Install stud plate (14) and lifting eyes (13) on roof armor (6).
4. Install stud plate (1) on left-front edge of roof armor (6). Attach stud plate to roof armor with two new loosely installed locknuts (2).
5. Install stud plate (22) on left-rear edge of roof armor (6). Attach stud plate to roof armor with two new loosely installed locknuts (15).

**WARNING**

Use extreme caution when handling heavy parts. Provide adequate support and use assistance during procedure. Ensure that any lifting device used is in good condition and of suitable load capacity. Keep clear of heavy parts supported only by lifting device. Failure to follow this warning may cause injury or death to personnel.

NOTE

Roof armor weighs 166 lb (75 kg).

6. Attach sling and lifting device to two lifting eyes (13).
7. Use lifting device, install roof armor (6) on cab roof, aligning holes in right side of roof armor with holes in cab roof.
8. Remove sling and lifting device from roof armor (6).

INSTALLATION - CONTINUED



Use caution when using adhesives and sealants. Prolonged inhalation of vapors can cause lung irritation. Contact with skin can cause dermatitis. Wear gloves and safety goggles and use product in a well-ventilated area away from open flame. If ingested, keep individual calm and seek medical attention. DO NOT induce vomiting. If contact with skin or eyes is made, flush thoroughly with water. Dispose of cleanup rags IAW local policy and ordinances. Failure to follow this warning may cause injury to personnel.

9. Apply thread adhesive to two bolts (10). Install two spacers (11) and bolts (10) in opposite corners of escape hatch opening.
10. Apply thread adhesive to 10 bolts (7). Install 10 new lockwashers (8), washers (9), and bolts (7) on right side of roof armor (6).
11. Remove two loosely installed locknuts (15) from left-rear stud plate (22).
12. Install four washers (18) and bolts (19) through left-rear cab wall.
13. Install spacer plate (21) on four bolts (19).
14. Position left-rear roof armor bracket (20) on left-rear stud plate (22) and on four bolts (19).
15. Install four washers (16) and new locknuts (15) on left-rear stud plate (22). Hand tighten locknuts.
16. Install four washers (18) and new locknuts (17) on bolts (19) coming through left-rear cab wall. Hand tighten locknuts.
17. Remove two loosely installed locknuts (2) from left-front stud plate (1).
18. Install left-front roof armor bracket (4) on left-front stud plate (1).
19. Install six washers (3) and new locknuts (2) on left-front stud plate (1). Hand tighten locknuts.
20. Apply thread adhesive to five bolts (5). Tighten bolts to underside of front roof armor bracket (4).
21. Tighten six locknuts (2) on left-front roof armor bracket (4) to 35 lb-ft (47 Nm).
22. Tighten eight locknuts (15 and 17) on left-rear roof armor bracket (20) to 35 lb-ft (47 Nm).
23. Tighten 12 remaining roof armor bolts (7 and 10) to 18 lb-ft (24 Nm).

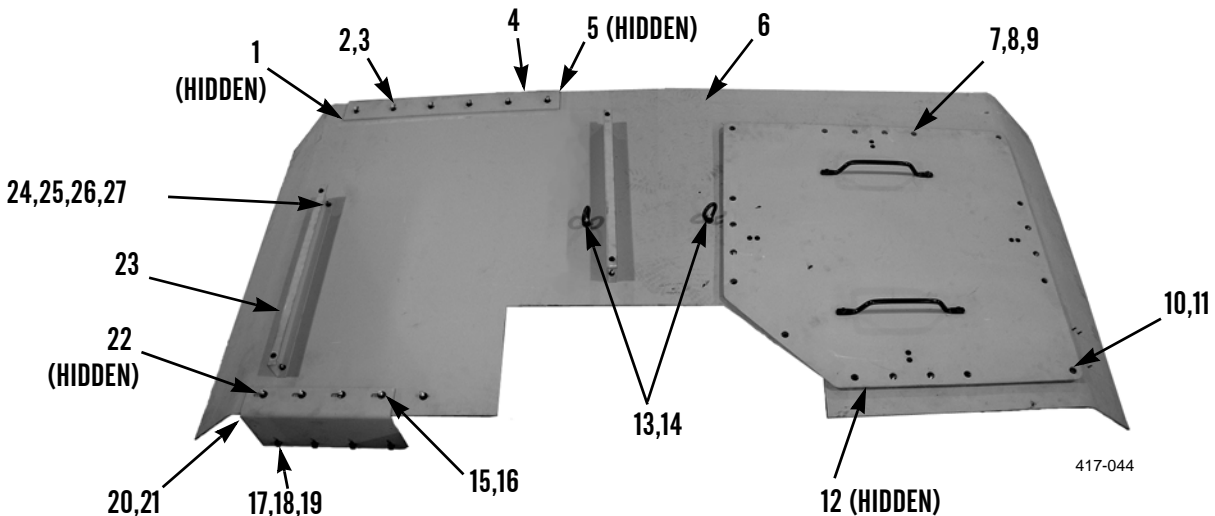

INSTALLATION - CONTINUED**WARNING**

Use caution when using adhesives and sealants. Prolonged inhalation of vapors can cause lung irritation. Contact with skin can cause dermatitis. Wear gloves and safety goggles and use product in a well-ventilated area away from open flame. If ingested, keep individual calm and seek medical attention. **DO NOT** induce vomiting. If contact with skin or eyes is made, flush thoroughly with water. Dispose of cleanup rags IAW local policy and ordinances. Failure to follow this warning may cause injury to personnel.

24. Apply bead of sealing compound around escape hatch opening between roof armor (6) and existing roof.
25. Install escape hatch (WP 0023 00).
26. If equipped, install C4ISR brackets (WP 0040 00).

END OF WORK PACKAGE

REAR CAB (RIGHT) ARMOR REPLACEMENT**0025 00****THIS WORK PACKAGE COVERS**

Removal, Cleaning and Inspection, Installation

INITIAL SETUP**Maintenance Level**

Unit

Tools and Special Tools

Tool Kit, General Mechanic's (Item 13, WP 0034 00)

Shop Equipment, Common No. 1 (Item 10, WP 0034 00)

Dispenser, Sealant (Item 2, WP 0034 00)

Link, Lifting (Item 8, WP 0034 00)

Sling (Item 11, WP 0034 00)

Lifting Device, 500-lb capacity

Materials/Parts

Adhesive, Thread (Item 1, WP 0035 00)

Rag, Wiping (Item 7, WP 0035 00)

Sealant, Urethane (Item 8, WP 0035 00)

Materials/Parts - Continued

Locknut (15)

Lockwasher (6)

References

WP 0011 00

Personnel Required

Two

Equipment Conditions

Vehicle parked on level ground (TM 9-2320-279-10)

Parking/Emergency Brake applied (TM 9-2320-279-10)

Engine off (TM 9-2320-279-10)

If equipped, Battery Disconnect Switch in OFF position (TM 9-2320-279-10)

Spare Tire removed (TM 9-2320-279-10)

REMOVAL

1. Remove four bolts (8), nuts (6), and lockwashers (7) from tire carrier (1) and fender (5). Discard lockwashers.
2. Remove two bolts (2), nuts (3), and lockwashers (4) from tire carrier (1). Discard lockwashers.

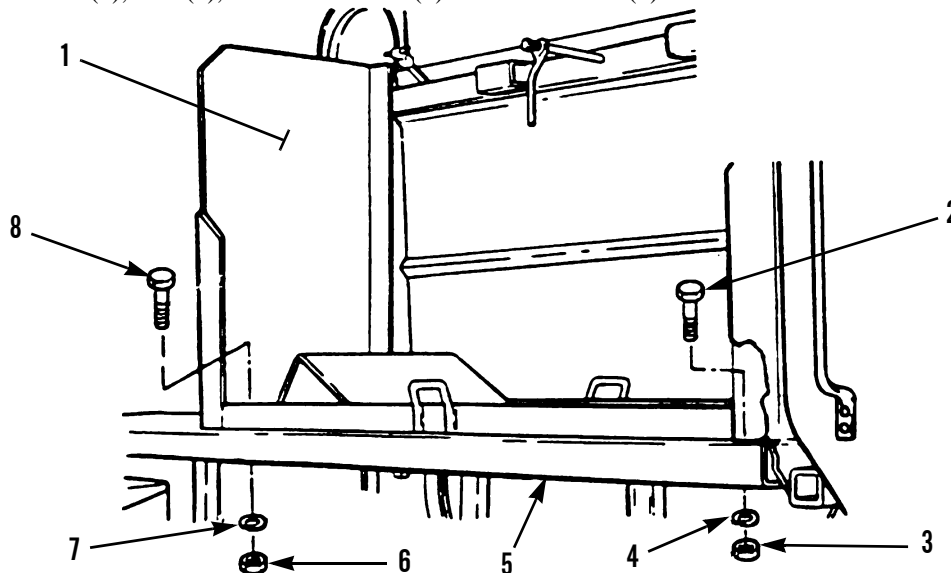

417-033

REAR CAB (RIGHT) ARMOR REPLACEMENT - CONTINUED**0025 00****REMOVAL - CONTINUED**

3. Slide tire carrier (1) away from rear window.
4. If equipped with 4-point seat belts, remove three locknuts (14), washers (15), and seat belt bracket (18). Discard locknuts.
5. Install lifting link, sling, and lifting device in center hole of right-rear cab armor (13).
6. Remove 12 locknuts (9), washers (10), bolts (11), and washers (12) from right-rear cab armor (13). Discard locknuts.
7. Loosen 12 bolts (16) and remove four brackets (17) from rear window opening.

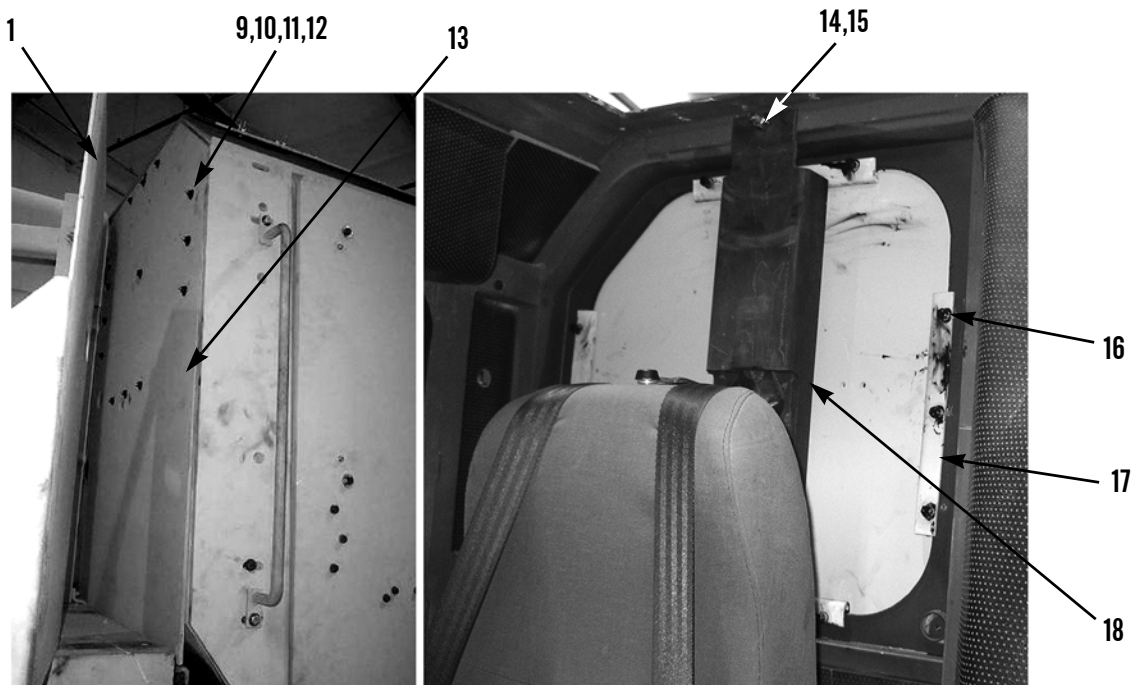

417-034

**WARNING**

Use extreme caution when handling heavy parts. Provide adequate support and use assistance during procedure. Ensure that any lifting device used is in good condition and of suitable load capacity. Keep clear of heavy parts supported only by lifting device. Failure to follow this warning may cause injury or death to personnel.

NOTE

Rear cab (right) armor weighs 100 lb (46 kg).

8. Using lifting device, remove right-rear cab armor (13) from vehicle.
9. Remove lifting device, sling, and lifting link from right-rear cab armor (13).

CLEANING AND INSPECTION

Clean and inspect all parts IAW *General Maintenance Instructions* (WP 0011 00).

INSTALLATION**WARNING**

Use caution when using adhesives and sealants. Prolonged inhalation of vapors can cause lung irritation. Contact with skin can cause dermatitis. Wear gloves and safety goggles and use product in a well-ventilated area away from open flame. If ingested, keep individual calm and seek medical attention. **DO NOT** induce vomiting. If contact with skin or eyes is made, flush thoroughly with water. Dispose of cleanup rags IAW local policy and ordinances. Failure to follow this warning may cause injury to personnel.

1. Apply thread adhesive to 12 bolts (11).
2. Install four brackets (17), 12 washers (12), bolts (11), washers (10), and new locknuts (9) on right-rear cab armor (13). Only hand tighten locknuts at this time.

**WARNING**

Use extreme caution when handling heavy parts. Provide adequate support and use assistance during procedure. Ensure that any lifting device used is in good condition and of suitable load capacity. Keep clear of heavy parts supported only by lifting device. Failure to follow this warning may cause injury or death to personnel.

NOTE

Rear cab (right) armor weighs 100 lb (46 kg).

3. Install lifting link, sling, and lifting device in center hole of right-rear cab armor (13).
4. Using lifting device, install right-rear cab armor (13) on vehicle.
5. Position four brackets (17) over edge of window opening.
6. Tighten locknuts (9) and bolts (16) to 108 lb-in. (12 Nm).
7. If equipped with 4-point seat belts, install seat belt bracket (18), three washers (15), and new locknuts (14) (NSN 5310-01-466-2695).

REAR CAB (RIGHT) ARMOR REPLACEMENT - CONTINUED**0025 00****INSTALLATION - CONTINUED**

8. Position tire carrier (1) and install two screws (2), new lockwashers (4), and nuts (3) on tire carrier.
9. Install four screws (8), new lockwashers (7), and nuts (6) on tire carrier (1) and fender (5).

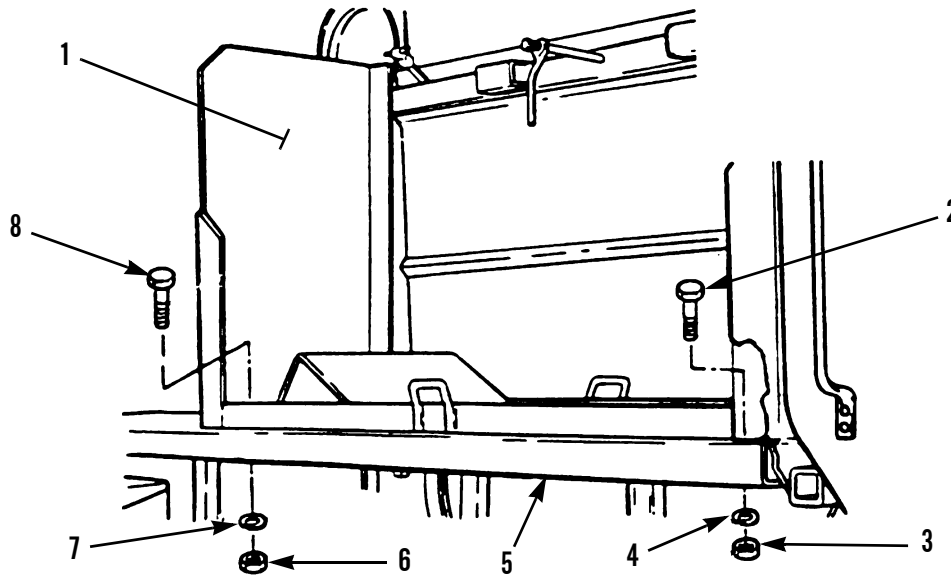

417-033

10. Apply bead of sealant between rear cab armor and window opening.
11. Install spare tire (TM 9-2320-279-10).

END OF WORK PACKAGE

REAR CAB (LEFT) ARMOR REPLACEMENT

0026 00

THIS WORK PACKAGE COVERS

Removal, Cleaning and Inspection, Installation

INITIAL SETUP

Maintenance Level

Unit

References

WP 0011 00

Tools and Special Tools

Tool Kit, General Mechanic's (Item 13, WP 0034 00)

Shop Equipment, Common No. 1 (Item 10, WP 0034 00)

Dispenser, Sealant (Item 2, WP 0034 00)

Link, Lifting (Item 8, WP 0034 00)

Sling (Item 11, WP 0034 00)

Lifting Device, 500-lb capacity

Personnel Required

Two

Equipment Conditions

Vehicle parked on level ground (TM 9-2320-279-10)

Parking/Emergency Brake applied (TM 9-2320-279-10)

Engine off (TM 9-2320-279-10)

Materials/Parts

Adhesive, Thread (Item 1, WP 0035 00)

Rag, Wiping (Item 7, WP 0035 00)

Sealant, Urethane (Item 8, WP 0035 00)

Locknut (25)

If equipped, Battery Disconnect Switch in OFF position (TM 9-2320-279-10)

If equipped, C4ISR Brackets removed (WP 0040 00)

REAR CAB (LEFT) ARMOR REPLACEMENT - CONTINUED

0026 00

REMOVAL

1. Install lifting link, sling, and lifting device in center hole of left-rear cab armor (16).
2. Remove two locknuts (21), washers (20), bolts (18), washers (19) and armored washers (17) from left-rear cab armor (16). Discard locknuts.
3. If equipped with 4-point seat belts, remove three locknuts (11), washers (12) and seat belt bracket (15). Discard locknuts.
4. Remove eight locknuts (9), washers (8), four bolts (6), washers (7), roof bracket (10) and spacer (5). Discard locknuts.
5. Remove 12 locknuts (4), washers (3), bolts (1) and washers (2) from left-rear cab armor (16). Discard locknuts.
6. Loosen 12 bolts (14) and remove brackets (13) from left-rear cab armor (16).

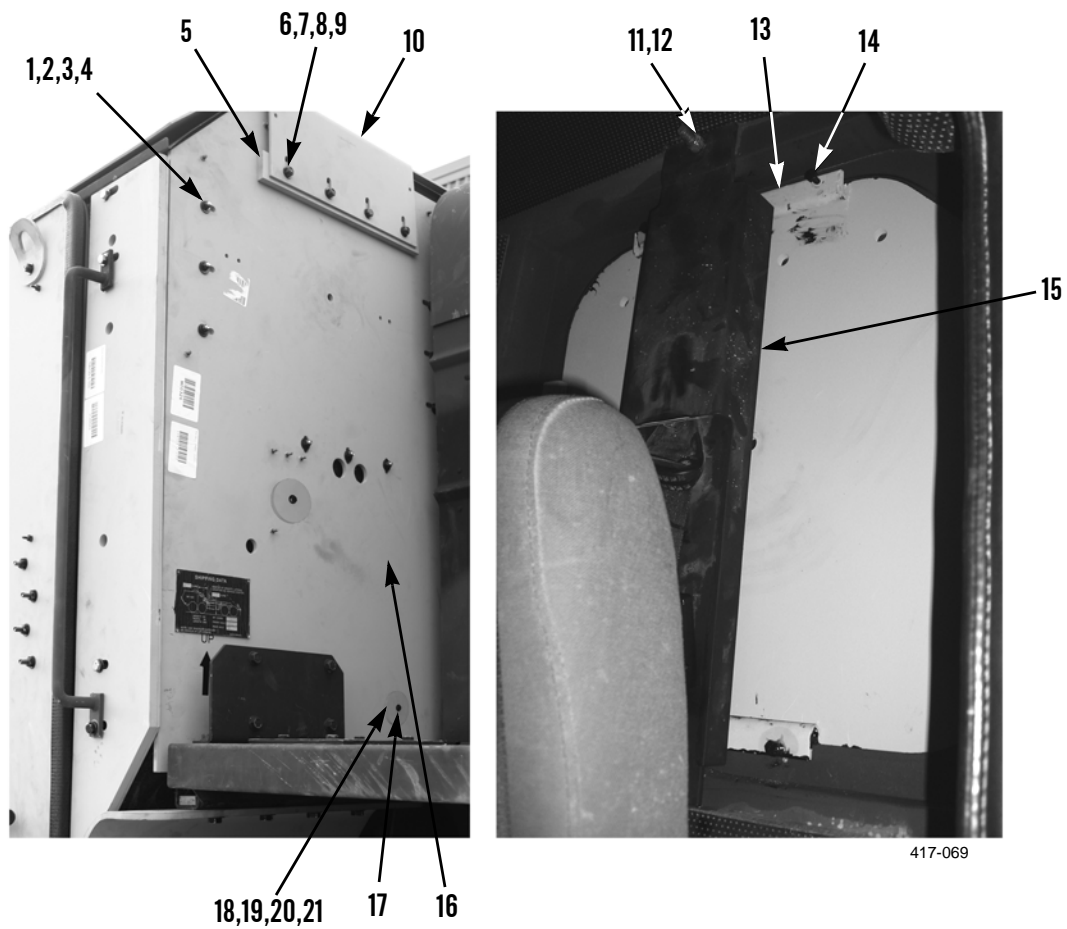

REMOVAL - CONTINUED**WARNING**

Use extreme caution when handling heavy parts. Provide adequate support and use assistance during procedure. Ensure that any lifting device used is in good condition and of suitable load capacity. Keep clear of heavy parts supported only by lifting device. Failure to follow this warning may cause injury or death to personnel.

NOTE

Rear cab (left) armor weighs 100 lb (46 kg).

7. Using lifting device, remove left-rear cab armor (16) from vehicle.
8. Remove lifting device, sling, and lifting link from left-rear cab armor (16).

CLEANING AND INSPECTION

Clean and inspect all parts IAW *General Maintenance Instructions* (WP 0011 00).

INSTALLATION**WARNING**

Use caution when using adhesives and sealants. Prolonged inhalation of vapors can cause lung irritation. Contact with skin can cause dermatitis. Wear gloves and safety goggles and use product in a well-ventilated area away from open flame. If ingested, keep individual calm and seek medical attention. **DO NOT** induce vomiting. If contact with skin or eyes is made, flush thoroughly with water. Dispose of cleanup rags IAW local policy and ordinances. Failure to follow this warning may cause injury to personnel.

1. Apply thread adhesive to 12 bolts (1).
2. Install four brackets (13), 12 washers (2), bolts (1), washers (3), and new locknuts (4) on left-rear cab armor (16). Only hand tighten locknuts at this time.

**WARNING**

Use extreme caution when handling heavy parts. Provide adequate support and use assistance during procedure. Ensure that any lifting device used is in good condition and of suitable load capacity. Keep clear of heavy parts supported only by lifting device. Failure to follow this warning may cause injury or death to personnel.

NOTE

Rear cab (left) armor weighs 100 lb (46 kg).

3. Install lifting link, sling, and lifting device on left-rear cab armor (16).

REAR CAB (LEFT) ARMOR REPLACEMENT - CONTINUED**0026 00****INSTALLATION - CONTINUED**

4. Using lifting device, install left-rear cab armor (16) on vehicle.
5. Position four brackets (13) over edge of window opening.
6. Tighten 12 locknuts (4) and bolts (14) to 108 lb-in. (12 Nm).
7. Install spacer (5), roof bracket (10), four washers (7), bolts (6), eight washers (8), and new locknuts (9).
8. Install two armored washers (17), washers (19), bolts (18), washers (20) and new locknuts (21) on left-rear cab armor (16).
9. If equipped with 4-point seat belts, install seat belt bracket (15), three washers (12), and new locknuts (11) (NSN 5310-01-466-2695).

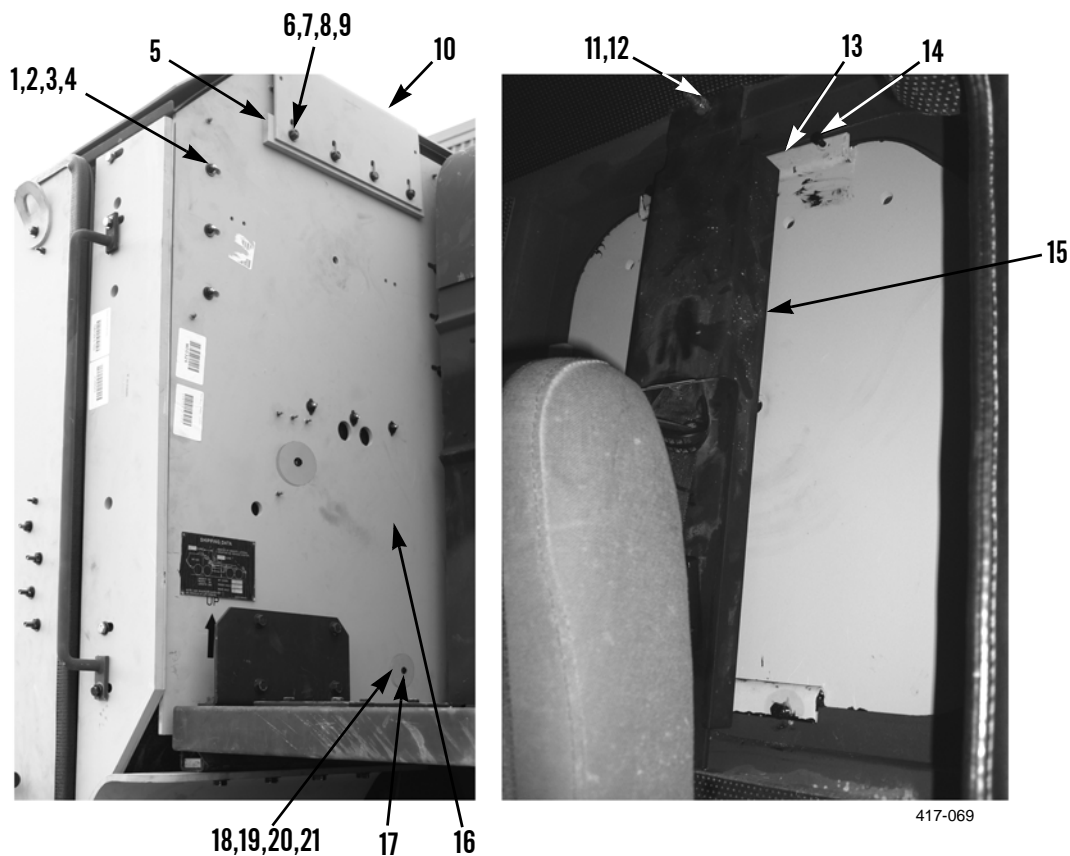

10. Apply bead of sealant between rear cab armor and window opening on inside of cab.
11. If equipped, install C4ISR brackets (WP 0040 00).

END OF WORK PACKAGE

RIGHT SIDE BLAST DEFLECTOR REPLACEMENT

0027 00**THIS WORK PACKAGE COVERS**Removal, Cleaning and Inspection, Installation

INITIAL SETUP**Maintenance Level**

Unit

Personnel Required

Two

Tools and Special Tools

Tool Kit, General Mechanic's (Item 13, WP 0034 00)

Shop Equipment, Common No. 1 (Item 10, WP 0034 00)

Lifting Device, 500-lb capacity

Equipment Conditions

Vehicle parked on level ground (TM 9-2320-279-10)

Parking/Emergency Brake applied (TM 9-2320-279-10)

Engine off (TM 9-2320-279-10)

Materials/Parts

Tag, Marker (Item 10, WP 0035 00)

Locknut (6)

If equipped, Battery Disconnect Switch in OFF position (TM 9-2320-279-10)

References

WP 0011 00

Center Blast Deflector removed (WP 0029 00)

Right Step removed (TM 9-2320-279-20)

REMOVAL**WARNING**

Use extreme caution when handling heavy parts. Provide adequate support and use assistance during procedure. Ensure that any lifting device used is in good condition and of suitable load capacity. Keep clear of heavy parts supported only by lifting device. Failure to follow this warning may cause injury or death to personnel.

NOTE

Side blast deflector weighs 145 lb (66 kg).

1. Attach and secure lifting device under side blast deflector (11).

NOTE

Bolt lengths are not the same. Tag bolts to ensure correct installation.

2. Remove three locknuts (3), washers (4), bolts (5), and washers (6) from front of side blast deflector (11). Discard locknuts.
3. Remove three locknuts (7), washers (8), bolts (9), and washers (10) from front of side blast deflector (11). Discard locknuts.
4. Remove four bolts (1) and washers (2) from rear of side blast deflector (11).
5. Use lifting device to remove side blast deflector (11) from under vehicle.

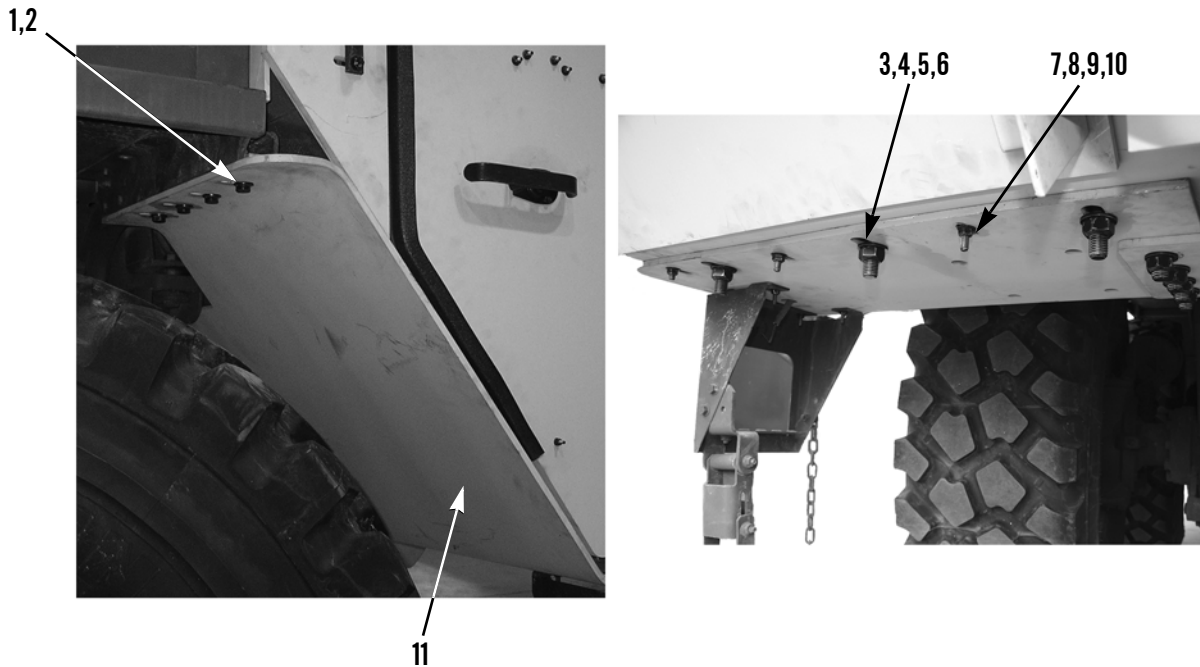

394-134

CLEANING AND INSPECTION

Clean and inspect all parts IAW *General Maintenance Instructions* (WP 0011 00).

INSTALLATION**WARNING**

Use extreme caution when handling heavy parts. Provide adequate support and use assistance during procedure. Ensure that any lifting device used is in good condition and of suitable load capacity. Keep clear of heavy parts supported only by lifting device. Failure to follow this warning may cause injury or death to personnel.

NOTE

- Side blast deflector weighs 145 lb (66 kg).
 - Position notch on inside edge of blast deflector in front of operator compartment support.
1. Attach and secure lifting device under side blast deflector (11). Move side blast deflector into position under vehicle.
 2. Install four washers (2) and bolts (1) on rear of side blast deflector (11) into threaded plate in fender support. Tighten bolts to 80 lb-ft (109 Nm).

NOTE

Bolt lengths are not the same. Ensure bolts are installed as tagged.

3. Install three washers (10), bolts (9), washers (8), and new locknuts (7) on front of side blast deflector (11). Hand tighten locknuts.
4. Install three washers (6), bolts (5), washers (4), and new locknuts (3) on front of side blast deflector (11). Hand tighten locknuts.
5. Tighten three locknuts (3) on front of side blast deflector (11) to 280 lb-ft (380 Nm).
6. Tighten three locknuts (7) on front of side blast deflector (11).
7. Install center blast deflector (WP 0029 00).
8. Install right step (TM 9-2320-279-20).

END OF WORK PACKAGE

LEFT SIDE BLAST DEFLECTOR REPLACEMENT

0028 00**THIS WORK PACKAGE COVERS**Removal, Cleaning and Inspection, Installation

INITIAL SETUP**Maintenance Level**

Unit

Tools and Special Tools

Tool Kit, General Mechanic's (Item 13, WP 0034 00)

Shop Equipment, Common No. 1 (Item 10, WP 0034 00)

Lifting Device, 500-lb capacity

Materials/Parts

Tag, Marker (Item 10, WP 0035 00)

Locknut (10)

References

WP 0011 00

Personnel Required

Two

Equipment Conditions

Vehicle parked on level ground (TM 9-2320-279-10)

Parking/Emergency Brake applied (TM 9-2320-279-10)

Engine off (TM 9-2320-279-10)

If equipped, Battery Disconnect Switch in OFF position (TM 9-2320-279-10)

Left Step removed (TM 9-2320-279-20)

REMOVAL**WARNING**

Use extreme caution when handling heavy parts. Provide adequate support and use assistance during procedure. Ensure that any lifting device used is in good condition and of suitable load capacity. Keep clear of heavy parts supported only by lifting device. Failure to follow this warning may cause injury or death to personnel.

NOTE

Side blast deflector weighs 145 lb (66 kg).

1. Attach and secure lifting device under side blast deflector (5).
2. Remove four locknuts (12), washers (11), spacer (13), and shield (14) from left side blast deflector (5). Discard locknuts.
3. Remove four bolts (2), washers (1), and spacer (15) from left side blast deflector (5).

NOTE

Bolt lengths are not the same. Tag bolts to ensure correct installation.

4. Remove six locknuts (10), washers (9), and bolts (8) from left side blast deflector (5). Discard locknuts.
5. Remove four bolts (7) and washers (6) from left side blast deflector (5).
6. Use lifting device, remove side blast deflector (5) from under vehicle.

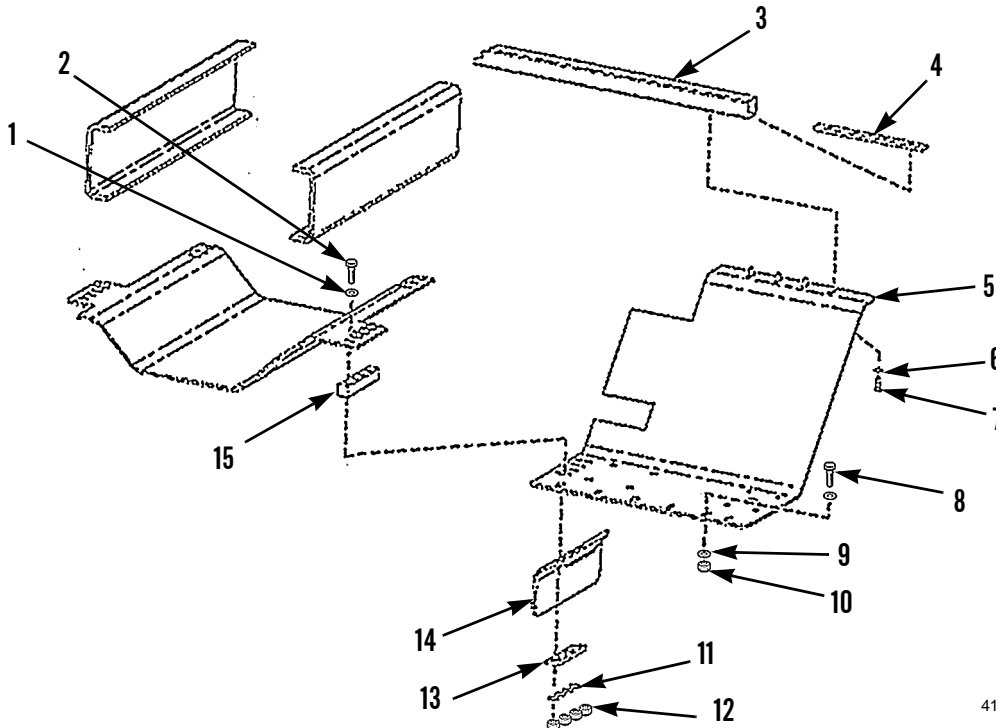

417-135

CLEANING AND INSPECTION

Clean and inspect all parts IAW *General Maintenance Instructions* (WP 0011 00).

INSTALLATION**WARNING**

Use extreme caution when handling heavy parts. Provide adequate support and use assistance during procedure. Ensure that any lifting device used is in good condition and of suitable load capacity. Keep clear of heavy parts supported only by lifting device. Failure to follow this warning may cause injury or death to personnel.

NOTE

- Side blast deflector weighs 145 lb (66 kg).
 - Position notch on inside edge of blast deflector in front of operator compartment support.
1. Attach and secure lifting device under side blast deflector (5). Move side blast deflector into position under vehicle.
 2. Install four washers (6) and bolts (7) on left side blast deflector (5) into threaded plate (4) in fender support (3). Hand tighten bolts.
 3. Install spacer (15), four washers (1), and bolts (2) on left side blast deflector (5).
 4. Install shield (14), spacer (13), four washers (11), and new locknuts (12) on left side blast deflector (5). Hand tighten locknuts.

NOTE

Bolt lengths are not the same. Ensure bolts are installed as tagged.

5. Install six bolts (8), washers (9), and new locknuts (10) on left side blast deflector (5). Hand tighten locknuts.
6. Tighten four bolts (7) to 80 lb-ft (109 Nm).
7. Tighten three 3/4 inch locknuts (10) on left side blast deflector (5) to 280 lb-ft (380 Nm).
8. Tighten three 1/2 inch locknuts (10) on left side blast deflector (5).
9. Tighten four locknuts (12) on left side blast deflector (5) to 280 lb-ft (380 Nm).
10. Install left step (TM 9-2320-279-20).

END OF WORK PACKAGE

CENTER BLAST DEFLECTOR REPLACEMENT

0029 00

THIS WORK PACKAGE COVERS

Removal, Cleaning and Inspection, Installation

INITIAL SETUP

Maintenance Level

Unit

Tools and Special Tools

Tool Kit, General Mechanic's (Item 13, WP 0034 00)

Shop Equipment, Common No. 1 (Item 10, WP 0034 00)

Lifting Device, 500-lb capacity

Materials/Parts

Adhesive, Thread (Item 1, WP 0035 00)

Rag, Wiping (Item 7, WP 0035 00)

Locknut (10)

Lockwasher

References

WP 0011 00

Personnel Required

Two

Equipment Conditions

Vehicle parked on level ground (TM 9-2320-279-10)

Parking/Emergency Brake applied (TM 9-2320-279-10)

Engine off (TM 9-2320-279-10)

If equipped, Battery Disconnect Switch in OFF position (TM 9-2320-279-10)

Left Side Blast Deflector removed (WP 0028 00)

REMOVAL

NOTE

- It is necessary to disconnect drag link from steering gear pitman arm in order to remove center blast deflector.
- Do not move vehicle while drag link is disconnected, to ensure holes align correctly when drag link is reconnected.

CENTER BLAST DEFLECTOR REPLACEMENT - CONTINUED**0029 00****REMOVAL - CONTINUED**

1. Remove nut (11), lockwasher (10), and screw (9) from pitman arm. Discard lockwasher.
2. Disconnect drag link (8) from pitman arm.

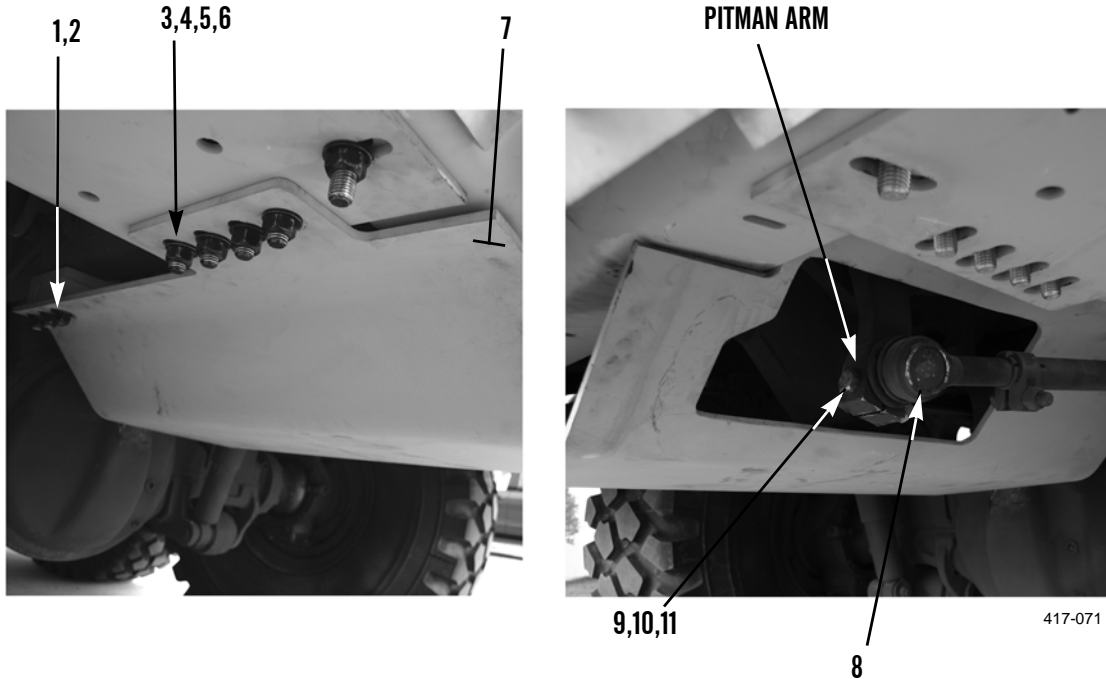
**WARNING**

Use extreme caution when handling heavy parts. Provide adequate support and use assistance during procedure. Ensure that any lifting device used is in good condition and of suitable load capacity. Keep clear of heavy parts supported only by lifting device. Failure to follow this warning may cause injury or death to personnel.

NOTE

Center blast deflector weighs 147 lb (67 kg).

3. Attach and secure lifting device under center blast deflector (7).
4. Remove four locknuts (3), washers (4), bolts (5), and washers (6) from right side of center blast deflector (7). Discard locknuts.
5. Remove six locknuts (1) and washers (2) from center blast deflector (7). Discard locknuts.
6. Using lifting device, remove center blast deflector (7) from under vehicle.
7. If necessary, loosen two bolts (12) and remove center blast deflector bracket (15).
8. If necessary, loosen two bolts (13) and remove center blast deflector bracket (14).

CLEANING AND INSPECTION

Clean and inspect all parts IAW *General Maintenance Instructions* (WP 0011 00).

INSTALLATION**WARNING**

Use caution when using adhesives and sealants. Prolonged inhalation of vapors can cause lung irritation. Contact with skin can cause dermatitis. Wear gloves and safety goggles and use product in a well-ventilated area away from open flame. If ingested, keep individual calm and seek medical attention. **DO NOT** induce vomiting. If contact with skin or eyes is made, flush thoroughly with water. Dispose of cleanup rags IAW local policy and ordinances. Failure to follow this warning may cause injury to personnel.

1. If removed, install center blast deflector brackets (14 and 15) with forward surface against rear edge of crossmember and studs facing the ground. Tighten two bolts (12) and bolts (13).
2. Apply thread adhesive to four bolts (5).

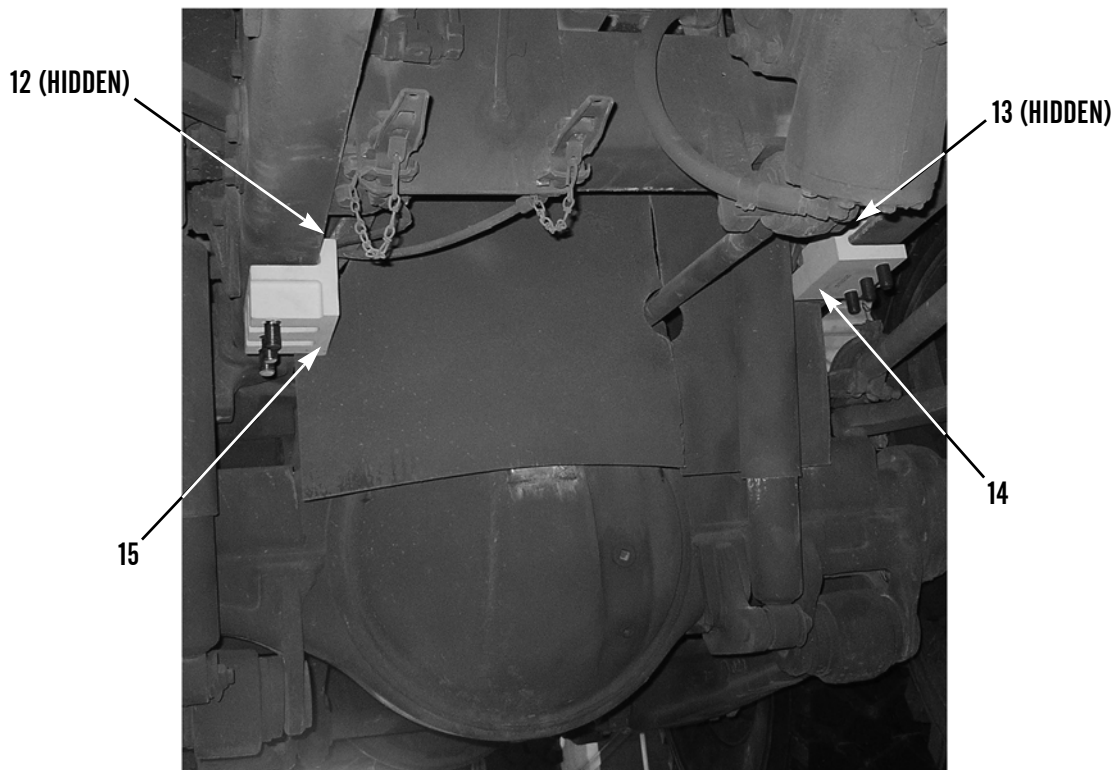

417-072

INSTALLATION - CONTINUED**WARNING**

Use extreme caution when handling heavy parts. Provide adequate support and use assistance during procedure. Ensure that any lifting device used is in good condition and of suitable load capacity. Keep clear of heavy parts supported only by lifting device. Failure to follow this warning may cause injury or death to personnel.

NOTE

- Center blast deflector weighs 147 lb (67 kg).
 - Position center blast deflector with left edge above left side blast deflector and with right edge below right side blast deflector.
3. Attach and secure lifting device under center blast deflector (7).
 4. Using lifting device, install center blast deflector (7) on vehicle.
 5. Install six washers (2) and new locknuts (1) on center blast deflector (7). Tighten locknuts to 280 lb-ft (380 Nm).
 6. Install four washers (6), bolts (5), washers (4), and new locknuts (3) on right side of center blast deflector (7). Tighten locknuts to 280 lb-ft (380 Nm).
 7. Connect drag link (8) to pitman arm.
 8. Install screw (9), new lockwasher (10), and nut (11) on pitman arm
 9. Install left blast deflector (WP 0028 00).

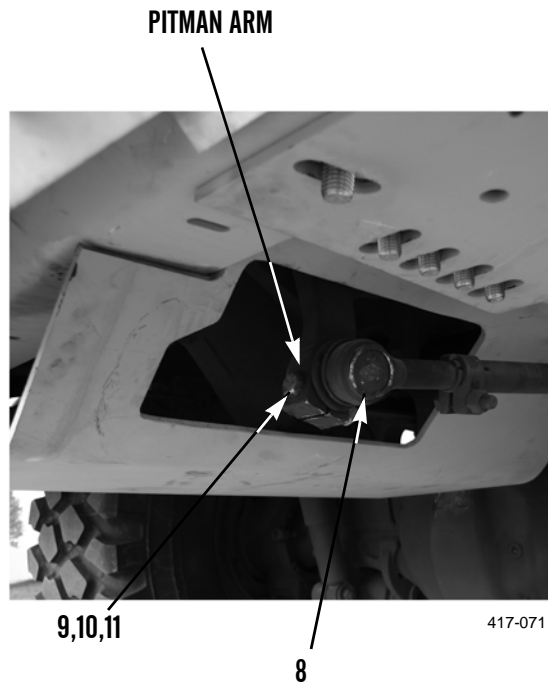
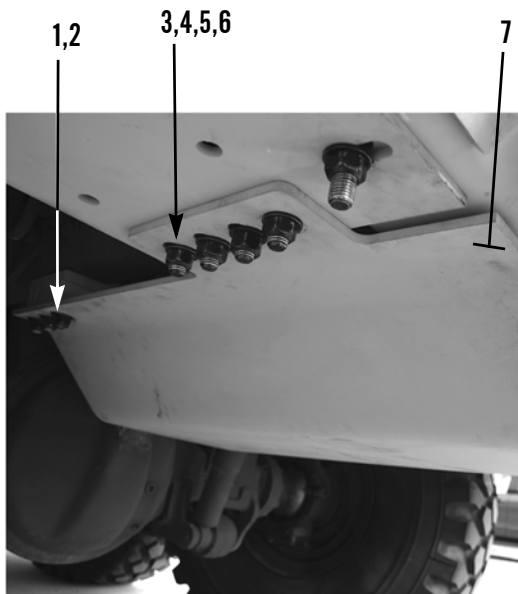
**END OF WORK PACKAGE**

REAR SIDE ARMOR REPLACEMENT

0030 00**THIS WORK PACKAGE COVERS**Removal, Cleaning and Inspection, Installation

INITIAL SETUP**Maintenance Level**

Unit

References

WP 0011 00

Tools and Special Tools

Tool Kit, General Mechanic's (Item 13, WP 0034 00)

Shop Equipment, Common No. 1 (Item 10, WP 0034 00)

Equipment Conditions

Vehicle parked on level ground (TM 9-2320-279-10)

Parking/Emergency Brake applied (TM 9-2320-279-10)

Materials/Parts

Rag, Wiping (Item 7, WP 0035 00)

Locknut (4)

Engine off (TM 9-2320-279-10)

If equipped, Battery Disconnect Switch in OFF position (TM 9-2320-279-10)

NOTE

The following procedure is for left rear side armor. Right side is identical.

REAR SIDE ARMOR REPLACEMENT - CONTINUED**0030 00****REMOVAL**

1. Remove two locknuts (6), washers (7), and attachment plates (1 and 8). Discard locknuts.
2. Remove two bolts (15), washers (16), and handle (19) from vehicle.

NOTE

Seat belt brackets in this procedure apply only to vehicles with a 3-point seat belt system.

3. Remove locknuts (4 and 9), washers (5 and 10), seat belt brackets (3 and 11), and attachment plates (2 and 12). Discard locknuts.
4. Remove two bolts (17), washers (18), and cab side (rear) armor (13 and 14).

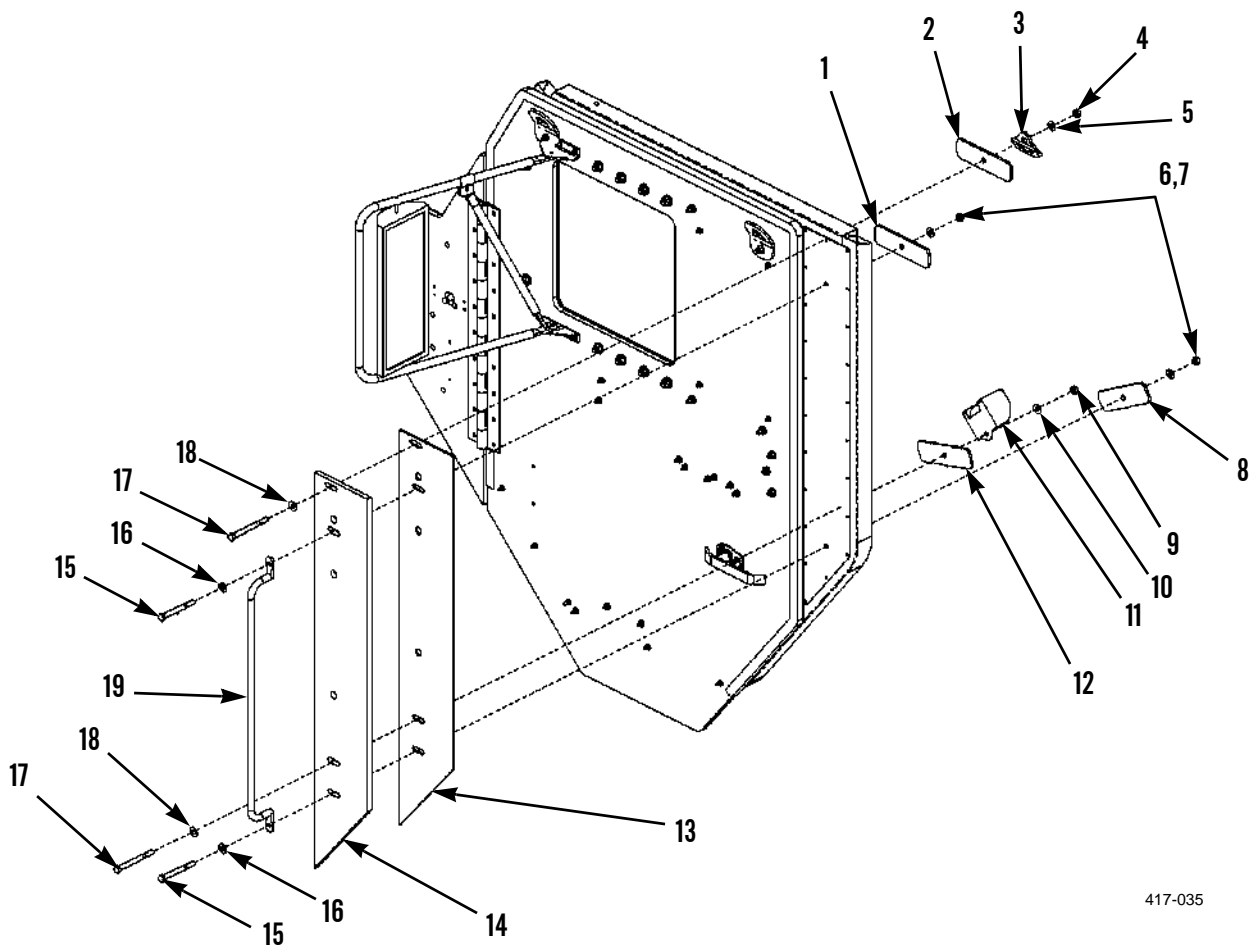

417-035

CLEANING AND INSPECTION

Clean and inspect all parts IAW *General Maintenance Instructions* (WP 0011 00).

INSTALLATION**NOTE**

Position thinner panel on vehicle first, then thicker panel.

1. Install cab side (rear) armor (14 and 13) on left side of vehicle.
2. Install two washers (18) and bolts (17) through cab side (rear) armor (14 and 13).

NOTE

Seat belt brackets in this procedure apply only to vehicles with a 3-point seat belt system.

3. Install attachment plate (2), seat belt bracket (3), washer (5), and new locknut (4). Only hand tighten locknut at this time.
4. Install attachment plate (12), seat belt bracket (11), washer (10) and new locknut (9). Only hand tighten locknut at this time.
5. Install handle (19), two washers (16), bolts (15), attachment plates (1 and 8), two washers (7), and new locknuts (6). Only hand tighten locknuts at this time.
6. Close cab door and measure gap between rear edge of door and front edge of cab side (rear) armor (13 and 14). Gap should be between 1/8 in. (3.2 mm) and 3/8 in. (9.5 mm). Adjust position of cab side (rear) armor as necessary.
7. Tighten locknuts (4,6, and 9) to 35 ft-lb (47.5 Nm).

END OF WORK PACKAGE

FRONT SIDE ARMOR ASSEMBLY REPLACEMENT

0031 00

THIS WORK PACKAGE COVERS

Removal, Cleaning and Inspection, Installation

INITIAL SETUP

Maintenance Level

Unit

References

WP 0011 00

Tools and Special Tools

Tool Kit, General Mechanic's (Item 13, WP 0034 00)

Equipment Conditions

Vehicle parked on level ground (TM 9-2320-279-10)

Parking/Emergency Brake applied (TM 9-2320-279-10)

Materials/Parts

Rag, Wiping (Item 7, WP 0035 00)

Engine off (TM 9-2320-279-10)

Sealant, Urethane (Item 8, WP 0035 00)

If equipped, Battery Disconnect Switch in OFF position (TM 9-2320-279-10)

Locknut (14)

Door Assembly removed (WP 0015 00)

NOTE

The following procedure is for left side. Right side is identical.

REMOVAL

1. Remove nine bolts (3) from hinge bracket (13).

**WARNING**

Use extreme caution when handling heavy parts. Provide adequate support and use assistance during procedure. Failure to follow this warning may cause injury to personnel.

NOTE

Side armor assembly weighs 49 lb (22 kg).

2. With assistance, remove four bolts (1), washers (2), and side armor assembly (5).
3. Disconnect side marker electrical connector (4) from behind side armor panel (5).

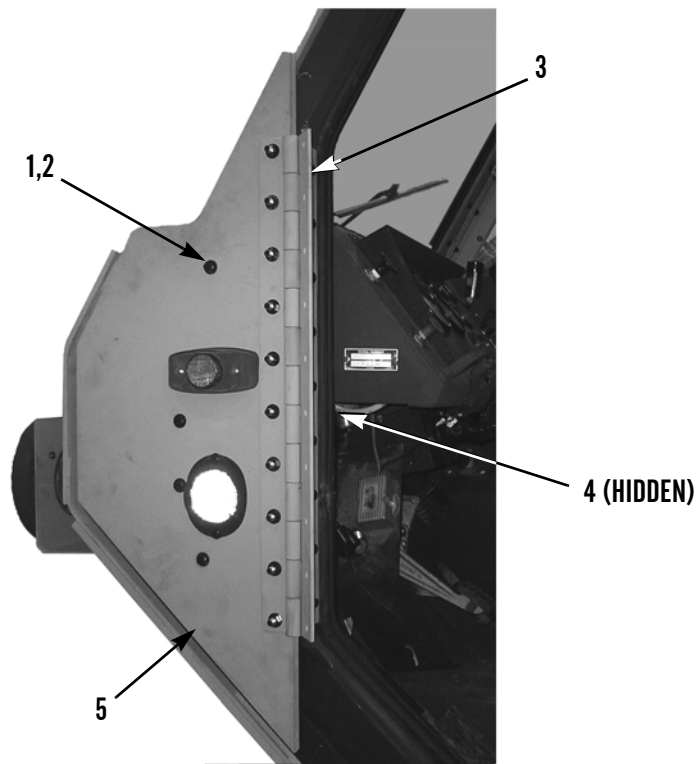

417-060

FRONT SIDE ARMOR ASSEMBLY REPLACEMENT - CONTINUED

0031 00

DISASSEMBLY

1. Remove two screws (6), washers (7), nuts (11), washers (12), and reflector (8) from side armor (5).
2. Remove two screws (10) and side marker cover (9) from side armor (5).
3. Remove four bolts (14), locknuts (15), and side marker (20) from side armor (5). Discard locknuts.
4. Remove 10 bolts (16), washers (17), and locknuts (18) from side armor (5). Discard locknuts.
5. Remove bracket (13) and hinge (19) from side armor (5).

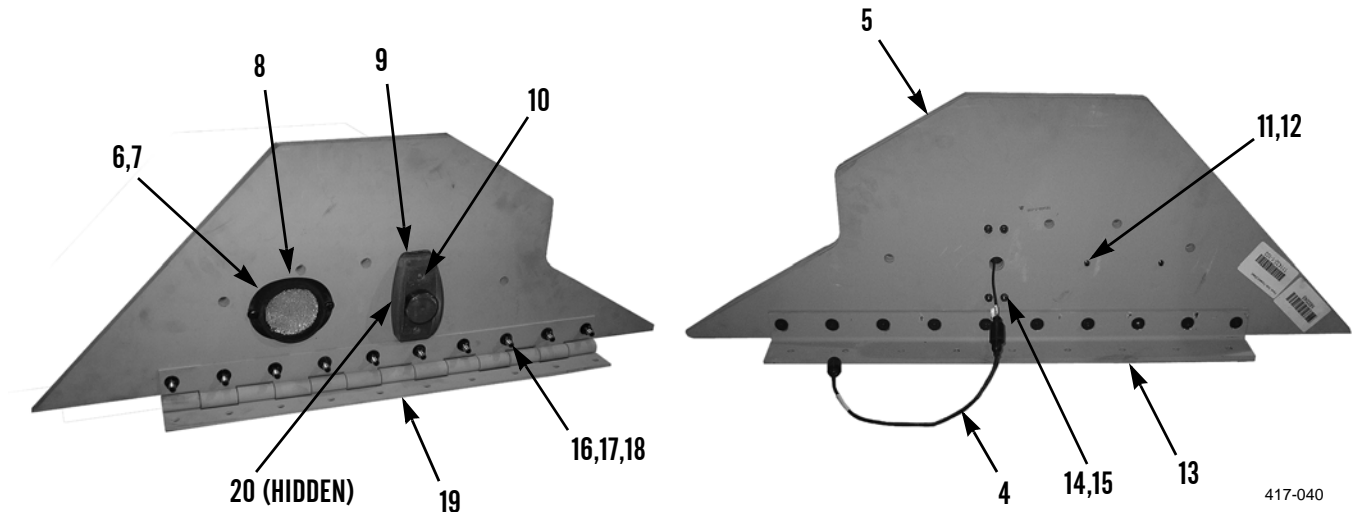
**CLEANING AND INSPECTION**

Clean and inspect all parts IAW *General Maintenance Instructions* (WP 0011 00).

ASSEMBLY

1. Install bracket (13) and hinge (19) on side armor (5).
2. Install 10 bolts (16), washers (17) and new locknuts (18) on side armor (5).
3. Install side marker (20), four bolts, (14) and new locknuts (15).
4. Install side marker cover (9) and two screws (10) on side marker (20).
5. Install reflector (8), two washers (12), nuts (11), washers (7) and screws (6).

INSTALLATION

1. Using sealing compound, attach four spacers (21) to side of cab.

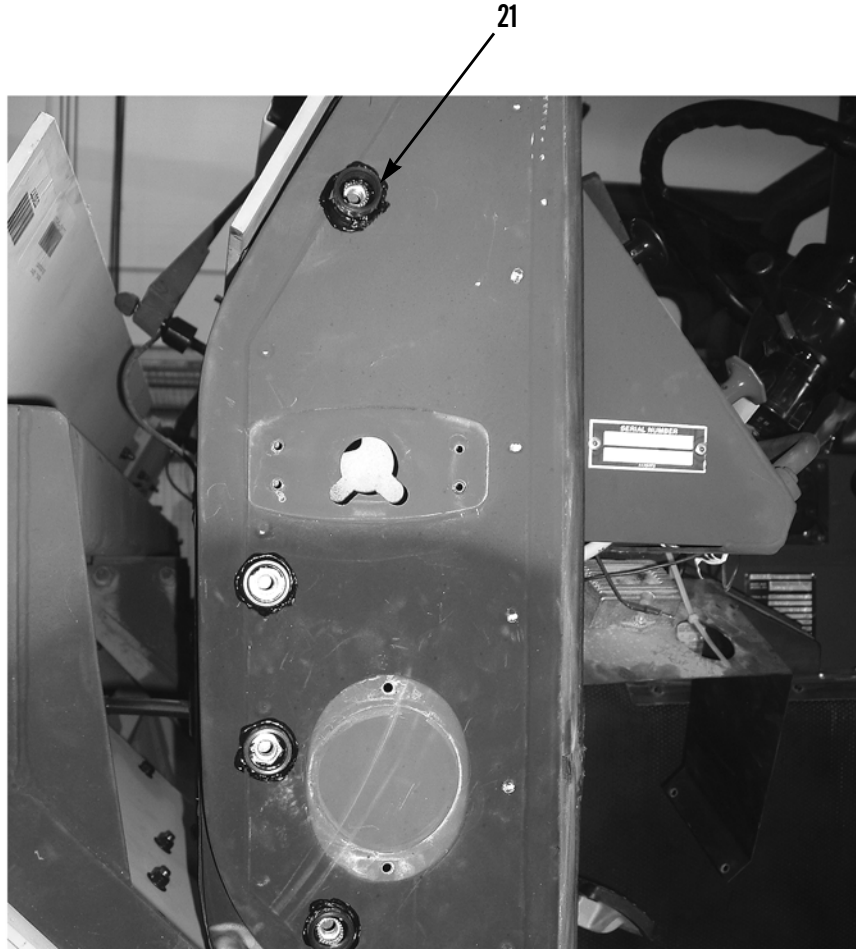

417-039

INSTALLATION - CONTINUED**WARNING**

Use extreme caution when handling heavy parts. Provide adequate support and use assistance during procedure. Failure to follow this warning may cause injury to personnel.

NOTE

Side armor assembly weighs 49 lb (22 kg).

2. With assistance, position side armor assembly (5) and install four washers (2) and bolts (1) on side of cab.
3. Connect side marker electrical connector (4) to cab wire harness.
4. Install nine bolts (3) on side armor assembly (5).
5. Install door assembly (WP 0015 00).
6. Operate door and side marker to verify correct operation.

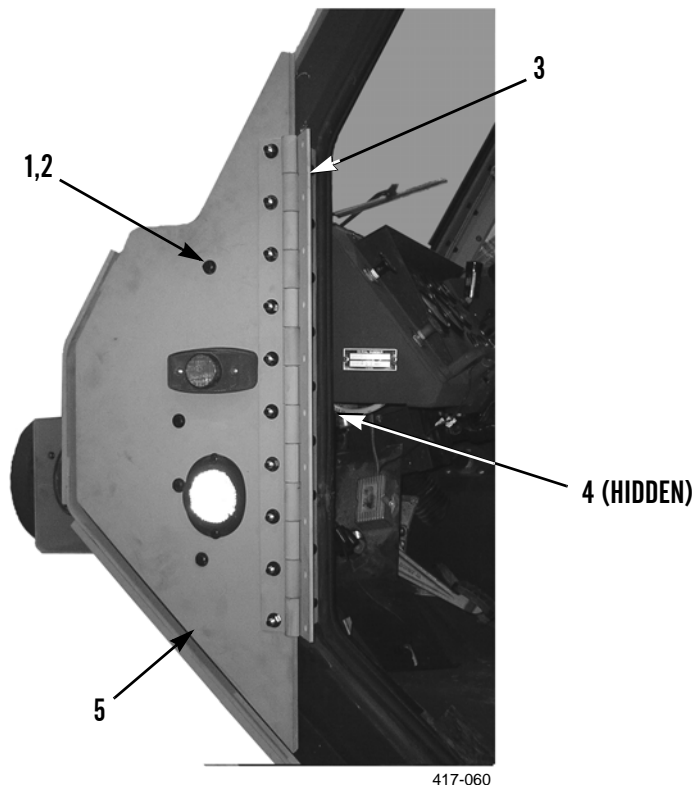
**END OF WORK PACKAGE**

THIS WORK PACKAGE COVERS

Removal, Cleaning and Inspection, Installation

INITIAL SETUP

Maintenance Level

Unit

Tools and Special Tools

Tool Kit, General Mechanic's (Item 13, WP 0034 00)

Shop Equipment, Common No. 1 (Item 10, WP 0034 00)

Sling, Nylon (Item 11, WP 0034 00)

Device, Lifting, 500-lb Capacity

Materials/Parts

Rag, Wiping (Item 7, WP 0035 00)

Locknut (17)

References

WP 0004 00

WP 0011 00

Personnel Required

Two

Equipment Conditions

Vehicle parked on level ground (TM 9-2320-279-10)

Parking/Emergency Brake applied (TM 9-2320-279-10)

Engine off (TM 9-2320-279-10)

Battery Disconnect Switch in OFF position (TM 9-2320-279-10)

Exterior Mirror removed (TM 9-2320-279-20)

NOTE

- The following procedure is for left side armor. Use same procedure for right side armor.
- Side armor can be removed from vehicle with door assembly installed.

REMOVAL

1. Disconnect side marker harness (5) from vehicle harness (4) on inside of cab.
2. Remove two screws (1) and side marker cover (3) from side marker (2).
3. Remove four screws (10) and side marker (2) from side of vehicle.
4. Remove screw (8) and disconnect ground wire (9) from back of side marker (2).
5. Remove two bolts (6) and reflector (7) from side of vehicle.

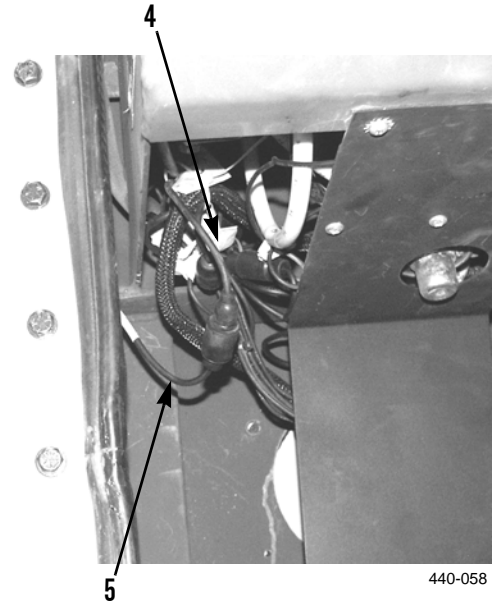
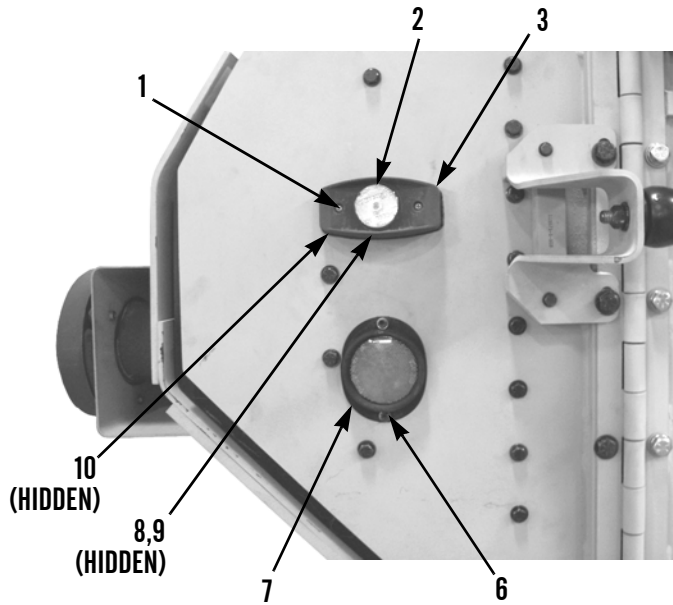

440-058

SIDE ARMOR REPLACEMENT - MODEL B - CONTINUED**0031 01****REMOVAL - CONTINUED**

6. Remove two locknuts (14), washers (15), attachment plates (13), bolts (11), washers (12), and grab handle (16) from side of vehicle. Discard locknuts.

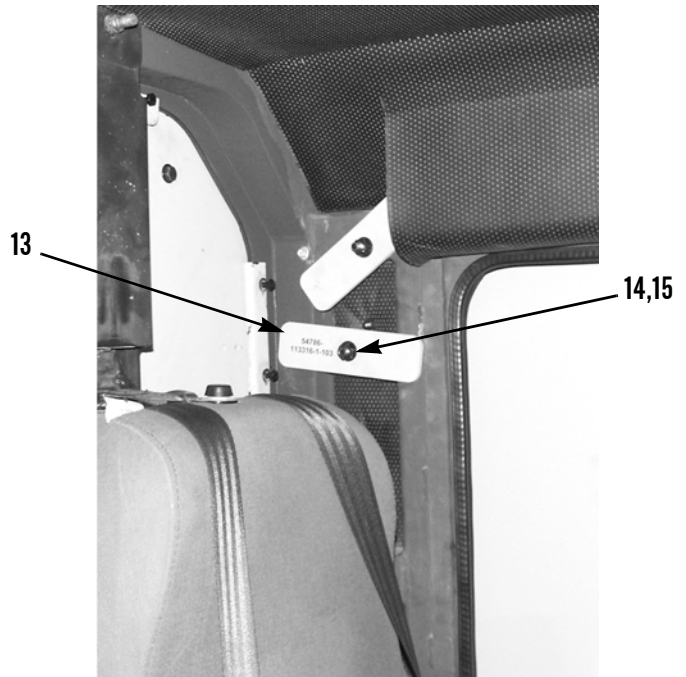
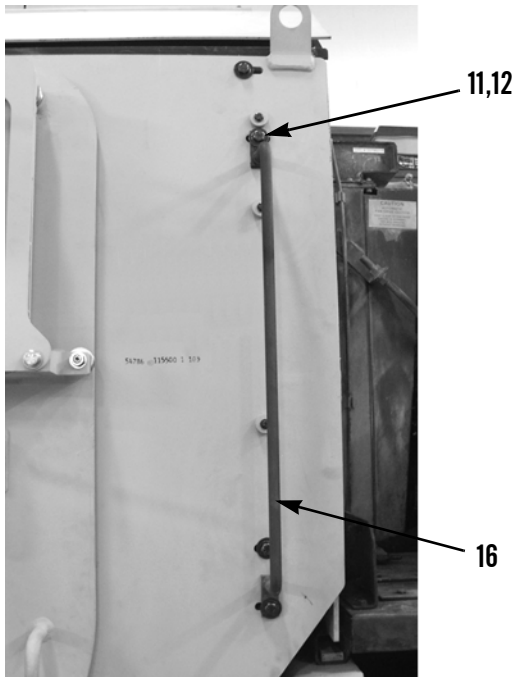

440-056

REMOVAL - CONTINUED**WARNING**

Use extreme caution when handling heavy parts. Provide adequate support and use assistance during procedure. Ensure that any lifting device used is in good condition and of suitable load capacity. Keep clear of heavy parts supported only by lifting device. Failure to follow this warning may cause injury or death to personnel.

CAUTION

Do not lift side armor with lifting eye on door. Use two lifting eyes located on side armor.

NOTE

Side armor weighs 360 lb (163 kg) without door installed.

7. Attach sling and lifting device to two lifting eyes (22) on side armor (37).
8. Remove three bolts (30), washers (31), armor washers (32), washers (23), and locknuts (24) from side of vehicle. Discard locknuts.
9. Remove nine bolts (35) and washers (36) from front and bottom edge of side armor (37).
10. Using lifting device, support weight of side armor (37) and remove 10 locknuts (18), washers (19), bolts (34), and washers (33) from side armor (37). Discard locknuts.
11. Using lifting device, remove two locknuts (25), washers (26), attachment plates (27), bolts (29), washers (28), and side armor (37) from vehicle. Discard locknuts.
12. Remove nine bolts (21), washers (20), and support bracket (17) from side of vehicle.

REMOVAL - CONTINUED

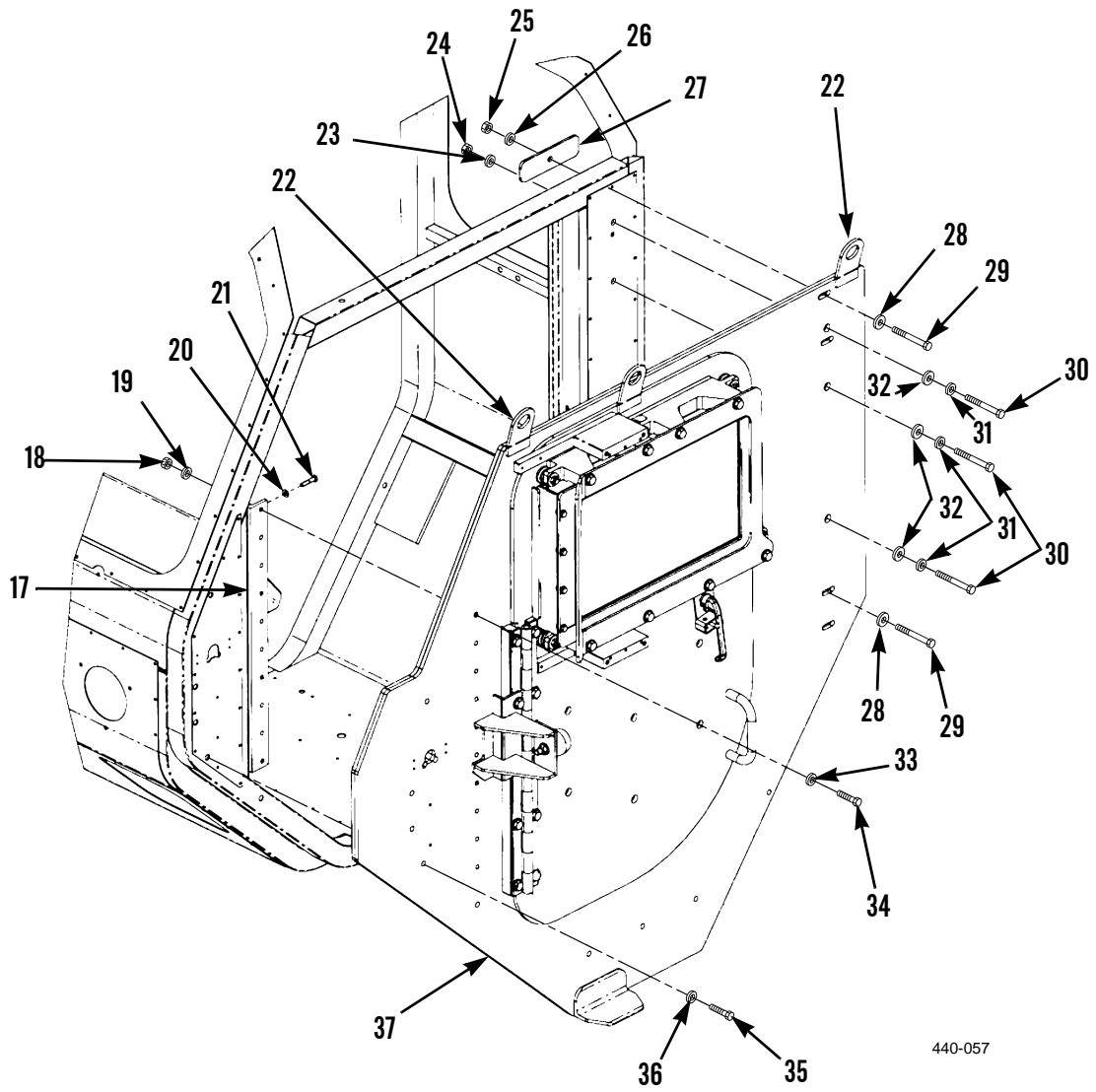

440-057

REMOVAL - CONTINUED

13. If necessary, remove seal (38) from side of cab.

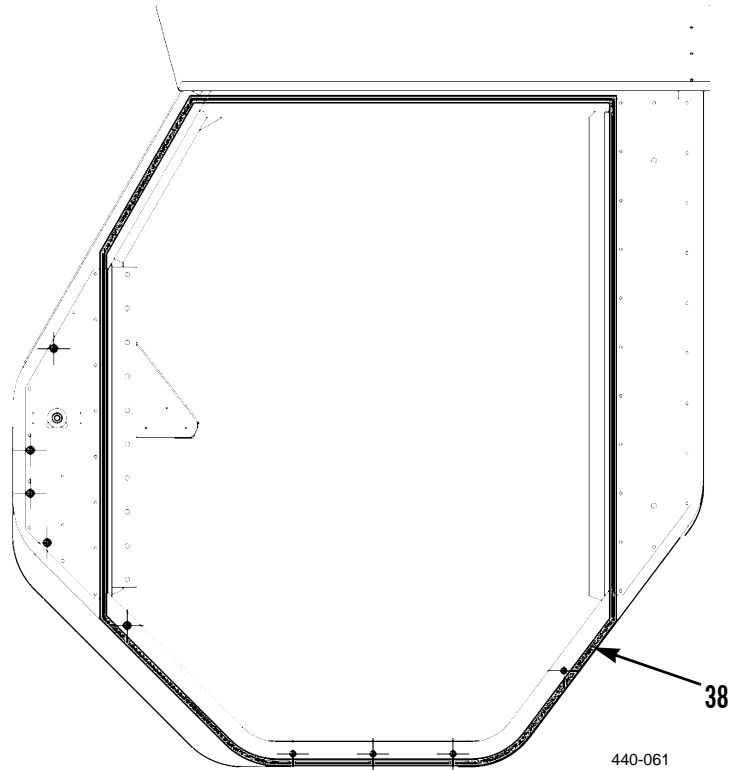
**CLEANING AND INSPECTION**

Clean and inspect all parts IAW *General Maintenance Instructions* (WP 0011 00).

INSTALLATION

1. If removed, install seal (38) by removing backing and apply to side of cab.
2. Install support bracket (17), nine washers (20), and bolts (21) on side of vehicle.

**WARNING**

Use extreme caution when handling heavy parts. Provide adequate support and use assistance during procedure. Ensure that any lifting device used is in good condition and of suitable load capacity. Keep clear of heavy parts supported only by lifting device. Failure to follow this warning may cause injury or death to personnel.

CAUTION

Do not lift side armor with lifting eye on door. Use two lifting eyes located on side armor.

NOTE

Side armor weighs 360 lb (163 kg) without door installed.

INSTALLATION - CONTINUED

3. Attach sling and lifting device to two lifting eyes (22) on side armor (37).

NOTE

Position top of side armor just below roof edge.

4. Using lifting device, install side armor (37), two washers (28), bolts (29), attachment plates (27), washers (26), and new locknuts (25) on side of vehicle.
5. Install 10 washers (33), bolts (34), washers (19), and new locknuts (18) on side of vehicle.
6. Install nine washers (36) and bolts (35) on front edge and bottom edge of side armor (37).
7. Install three armor washers (32), washers (31), bolts (30), washers (23), and new locknuts (24) on side armor (37).

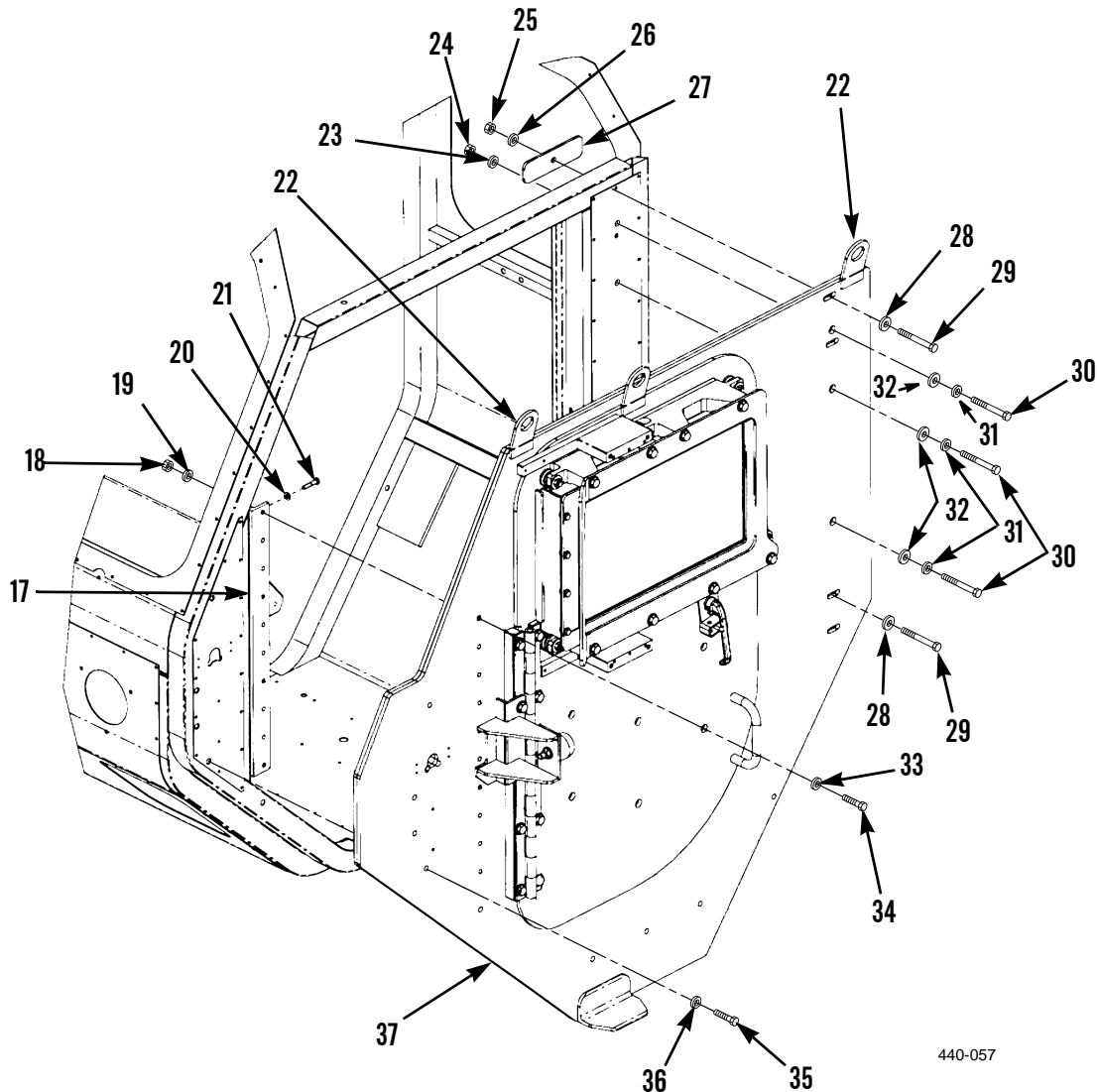

440-057

INSTALLATION - CONTINUED

8. Install grab handle (16), two washers (12), bolts (11), attachment plates (13), washers (15), and new locknuts (14) on side armor.

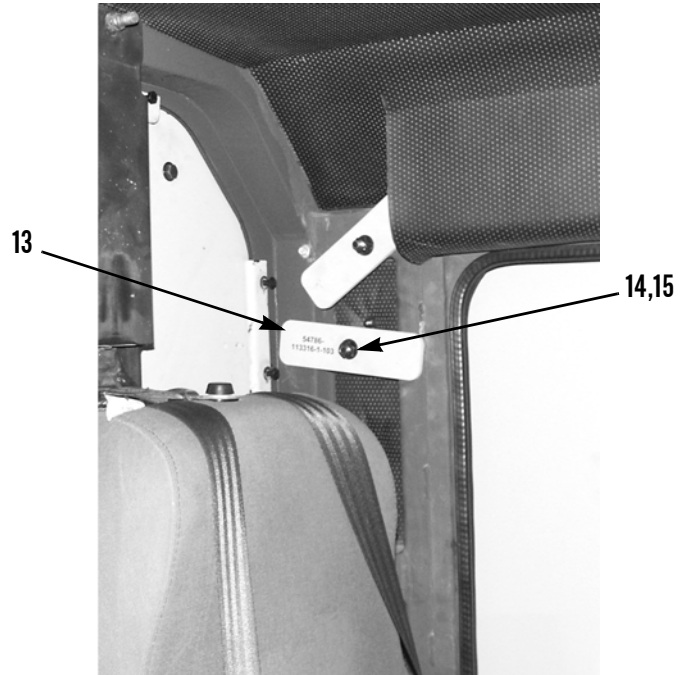
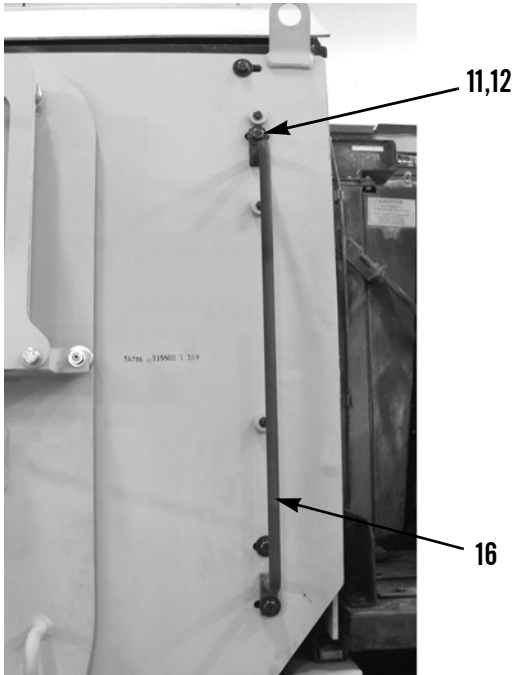

440-056

SIDE ARMOR REPLACEMENT - MODEL B - CONTINUED**0031 01****INSTALLATION - CONTINUED**

9. Install reflector (7) and two bolts (6) on side of vehicle.
10. Feed side marker harness (5) through side armor and connect to vehicle harness (4).
11. Connect ground wire (9) and install screw (8) on back of side marker (2).
12. Install side marker (2) and four screws (10) on side armor.
13. Install side marker cover (3) and two screws (1) on side marker (2).
14. Remove sling and lifting device from lifting eyes.

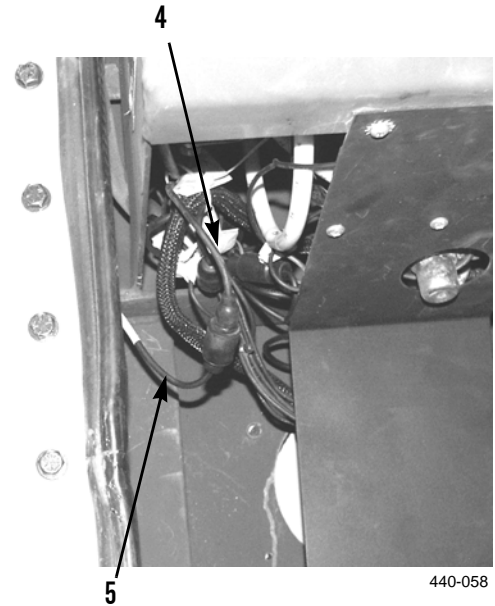
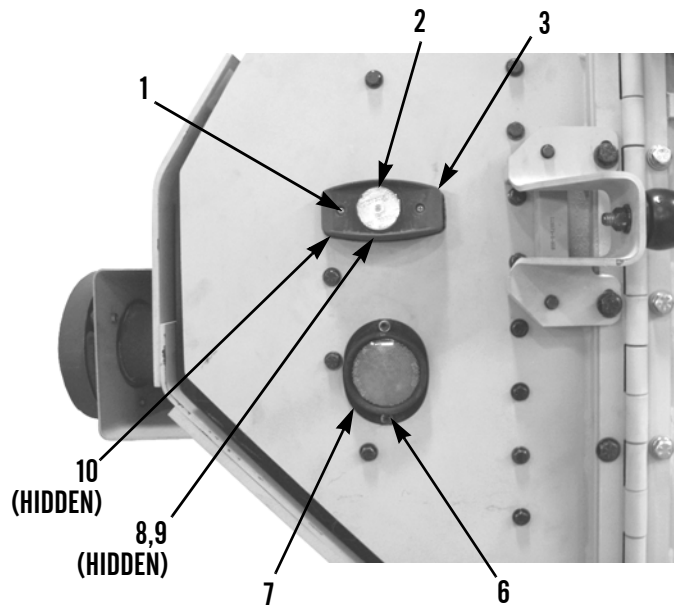

15. Verify correct operation of door assembly (WP 0004 00).
16. Install exterior mirror on door assembly (TM 9-2320-279-20).

END OF WORK PACKAGE

CHAPTER 5
SUPPORTING INFORMATION

REFERENCES

0032 00

SCOPE

This work package lists all publication indexes, forms, field manuals, technical bulletins, technical manuals, and other publications that are referenced in this manual and that apply to operation and maintenance of the Crew Protection Kit.

PUBLICATION INDEXES

The following indexes should be consulted frequently for latest changes or revisions and for new publications relating to material covered in this technical manual.

- Consolidated Army Publications and Forms Index. DA PAM 25-30
- The Army Maintenance Management System (TAMMS) Users Manual. DA PAM 750-8

FORMS

NOTE

Refer to DA PAM 750-8, *The Army Maintenance Management System (TAMMS) Users Manual*, for instructions on the use of maintenance forms.

- Equipment Inspection and Maintenance Worksheet DA Form 2404, DA Form 5988-E
- Product Quality Deficiency Report SF Form 368
- Recommended Changes to Publications and Blank Forms. DA Form 2028

FIELD MANUALS

- First Aid. FM 4-25.11

TECHNICAL BULLETINS

- CARC Spot Painting TB 43-0242
- Color, Marking, and Camouflage Painting of Military Vehicles, Construction Equipment,
and Materials Handling Equipment TB 43-0209

TECHNICAL MANUALS

- Maintenance Instructions for Organizational Maintenance, M977 Series, 8 X 8, Heavy Expanded
Mobility Tactical Trucks (HEMTT). TM 9-2320-279-20
- Materials Used for Cleaning, Preserving, Abrading, and Cementing Ordnance Materiel and
Related Materiels Including Chemicals TM 9-247
- Operator’s Manual for M977 Series, 8 X 8, Heavy Expanded Mobility Tactical Trucks (HEMTT) TM 9-2320-279-10
- Procedures for Destruction of Tank-automotive Equipment to Prevent Enemy Use
(U. S. Army Tank-automotive Command). TM 750-244-6
- Unit, Direct Support, and General Support Including Depot Maintenance RPSTL for the
M977 Series, 8 X 8, Heavy Expanded Mobility Tactical Truck (HEMTT). TM 9-2320-279-24P

OTHER PUBLICATIONS

- Standard Abbreviations ASME Y14.38-1999
- Army Medical Department Expendable/Durable Items CTA 8-100
- Expendable/Durable Items (Except Medical, Class V, Repair Parts, and Heraldic Items). CTA 50-970

END OF WORK PACKAGE

THE ARMY MAINTENANCE SYSTEM

1. This introduction provides a general explanation of all maintenance and repair functions authorized under the Two-Level Maintenance System.
2. The MAC for the Crew Protection Kit (Table 1, WP 0035 00) designates overall authority and responsibility for the performance of maintenance functions on the identified end item or component. The application of the maintenance functions to the end item or component shall be consistent with the capacities and capabilities of the designated maintenance levels, which are shown in column (4) as:

Field - includes subcolumns:

C - Operator/Crew

O - Unit

F - Direct Support

Sustainment - includes subcolumns:

H - General Support

D - Depot

3. Table 2 lists the tools and test equipment (both special tools and common tool sets) required for each maintenance function as referenced from the MAC.
4. Table 3 contains supplemental instructions and explanatory notes for particular maintenance functions.

MAINTENANCE FUNCTIONS

Maintenance functions are limited to and defined as follows:

1. **Inspect.** To determine the serviceability of an item by comparing its physical, mechanical, and/or electrical characteristics with established standards through examination (e.g., by sight, sound, or feel).
2. **Test.** To verify serviceability by measuring the mechanical, pneumatic, hydraulic, or electrical characteristics of an item and comparing those characteristics with prescribed standards on a scheduled basis, e.g., load testing of lift devices and hydrostatic testing of pressure hoses.
3. **Service.** Operations required periodically to keep an item in proper operating condition, e.g., to clean (includes decontaminate, when required), preserve, drain, paint, or replenish fuel, lubricants, chemical fluids, or gases.
4. **Adjust.** To maintain or regulate, within prescribed limits, by bringing into proper position, or by setting the operating characteristics to specified parameters.
5. **Align.** To adjust specified variable elements of an item to bring about optimum or desired performance.
6. **Calibrate.** To check and adjust Test, Measurement, and Diagnostic Equipment (TMDE) used in precision measurement. Calibration consists of comparisons of two instruments, one of which is a certified standard of known accuracy, to detect and adjust any discrepancy in the accuracy of the instrument being compared.
7. **Remove/Install.** To remove and install the same item when required to perform service or other maintenance functions. Installation may be the act of emplacing or seating a spare, repair part, or module (component or assembly) into position in a manner to allow the proper functioning of equipment or a system.
8. **Replace.** To remove an unserviceable item and install a serviceable counterpart in its place. Replacement is authorized by the MAC, and the assigned maintenance level is shown as the third position code of the Source, Maintenance and Recoverability (SMR) code.
9. **Repair.** Repair is the application of maintenance services, including fault location/troubleshooting, removal/installation, disassembly/assembly procedures, and maintenance actions to identify troubles and restore serviceability to an item by correcting specific damage, fault, malfunction, or failure in a part, subassembly, module (component or assembly), end item, or system.

MAINTENANCE FUNCTIONS - CONTINUED**NOTE**

The following definitions are applicable to the "repair" maintenance function:

- Services - Inspecting, testing, servicing, adjustment, alignment, calibration, and/or replacement.
 - Fault location/troubleshooting - The process of investigating and detecting the cause of equipment malfunctioning; the act of isolating a fault within a system or Unit Under Test (UUT).
 - Disassembly/assembly - The step-by-step breakdown (taking apart) of a spare/functional group coded item to the level of its least component, assigned an SMR code for the level of maintenance under consideration (i.e., identified as maintenance significant).
 - Actions - Welding, grinding, riveting, straightening, facing, machining, and/or resurfacing.
10. **Overhaul.** The maintenance effort (service/action) prescribed to restore an item to a completely serviceable/operational condition as required by maintenance standards in appropriate technical publications. Overhaul is normally the highest degree of maintenance performed by the Army. Overhaul does not normally return an item to like new condition.
11. **Rebuild.** Consists of services/actions necessary to restore unserviceable equipment to a like-new condition in accordance with original manufacturing standards. Rebuild is the highest degree of materiel maintenance applied to Army equipment. The rebuild operation includes the act of returning to zero the age measurements (hours/miles, etc.) considered in classifying Army equipment/components.

EXPLANATION OF COLUMNS IN THE MAC, TABLE 1

1. **Column (1) - Group Number.** Column (1) lists Group numbers, the purpose of which is to identify maintenance significant components, assemblies, subassemblies, and modules with the Next Higher Assembly (NHA).
2. **Column (2) - Component/Assembly.** Column (2) contains the item names of components, assemblies, subassemblies, and modules for which maintenance is authorized.
3. **Column (3) - Maintenance Function.** Column (3) lists the functions to be performed on the item listed in Column (2). (For a detailed explanation of these functions, refer to *Maintenance Functions*, above.)
4. **Column (4) - Maintenance Level.** Column (4) specifies each level of maintenance authorized to perform each function listed in column (3), by indicating work time required (expressed as manhours in whole hours or decimals) in the appropriate subcolumn. This work time figure represents the active time required to perform a maintenance function at the indicated level of maintenance. If the number or complexity of the tasks within the listed maintenance function varies at different maintenance levels, appropriate work time figures are to be shown for each level. The work time figure represents the average time required to restore an item (assembly, subassembly, component, module, end item, or system) to a serviceable condition under typical field operating conditions. This time includes preparation time (including any necessary disassembly/assembly time), troubleshooting/fault location time, and quality assurance time in addition to the time required to perform the specific tasks identified for the maintenance functions authorized in the MAC. The symbol designations for the various maintenance levels are as follows:

Field:

C - Operator/Crew Maintenance
 O - Unit Maintenance
 F - Direct Support Maintenance

Sustainment:

H - General Support Maintenance
 D - Depot Maintenance

EXPLANATION OF COLUMNS IN THE MAC, TABLE 1 - CONTINUED**NOTE**

The "L" maintenance level is not included in column (4) of the MAC. Functions at this level of maintenance are identified by a work time figure in the "H" column of column (4), and an associated reference code is used in the Remarks Code, column (6). This code is keyed to Table 3, and the SRA complete repair application is explained there.

5. **Column (5) - Tools and Equipment Reference Code.** Column (5) specifies, by code, common tool sets (not individual tools), common Test, Measurement, and Diagnostic Equipment (TMDE), special tools, special TMDE, and special support equipment required to perform the designated function. Codes are keyed to Table 2, the tools and test equipment table.
6. **Column (6) - Remarks Code.** When applicable, this column contains a letter code, in alphabetical order, which is keyed to the remarks in Table 3.

EXPLANATION OF COLUMNS IN THE TOOLS AND TEST EQUIPMENT REQUIREMENTS, TABLE 2

1. **Column (1) - Tool or Test Equipment Reference Code.** The tool and test equipment reference code correlates with a code used in column (5) of the MAC.
2. **Column (2) - Maintenance Level.** The lowest level of maintenance authorized to use the tool or test equipment.
3. **Column (3) - Nomenclature.** Name or identification of the tool or test equipment.
4. **Column (4) - National Stock Number (NSN).** The NSN of the tool or test equipment.
5. **Column (5) - Tool Number (CAGEC).** The manufacturer's part number, model number, or type number and the Commercial And Government Entity Code (CAGEC).

EXPLANATION OF COLUMNS IN THE REMARKS, TABLE 3

1. **Column (1) - Remarks Code.** The code recorded in column (6) of the MAC.
2. **Column (2) - Remarks.** Information pertinent to the maintenance function being performed as indicated in the MAC.

END OF WORK PACKAGE

MAINTENANCE ALLOCATION CHART (MAC)

0034 00

Table 1. MAC for the Crew Protection Kit.

(1) GROUP NUMBER	(2) COMPONENT/ ASSEMBLY	(3) MAINTENANCE FUNCTION	(4) MAINTENANCE LEVEL				(5) TOOLS AND EQUIPMENT REF CODE	(6) REMARKS CODE	
			FIELD		SUSTAINMENT				
			UNIT		DS	GS			DEPOT
			C	O	F	H			D
33	SPECIAL PURPOSE KITS								
3307	Crew Protection Kit:	Install		50.0			1,2,3,4,5,6,7,8,9,10,11,12,13		
	Vehicle Preparation	Install		17.0					
	Door Handle Assembly	Inspect Replace	0.2				13 A		
	Door Handle Assembly - Model B	Inspect Replace	0.2				13 A		
	Door Latch and Lock Pin	Inspect Replace	0.2				13 A		
	Door Latch and Combat Lock Model B	Inspect Replace	0.2				13 A		
	Door Ballistic Glass and Frame Assembly	Inspect Service Replace	0.2 0.2			2.0	13 A B		
	Door Ballistic Glass Assembly - Model B	Inspect Service Replace	0.2 0.2			2.0	13 A B		
	Door Assembly	Inspect Service Install Replace	0.2 0.2			3.0 2.0	10,11,13 10,11,13		
	Door Assembly - Model B	Inspect Service Replace	0.2 0.2			1.0	10,11,13 A B		
	Door Latch Adjustment	Inspect Service	0.2			0.2	13 A		
	Windshield Ballistic Glass (LH or RH)	Inspect Service	0.2 0.2				A B		
	Upper Brush Guard	Install		3.0			2,10,13		
		Replace		1.0			2,10,13		
		Inspect	0.2						
		Install		3.0			8,10,11,12,13		
		Replace		2.0			8,10,11,12,13		

MAINTENANCE ALLOCATION CHART (MAC) - CONTINUED

0034 00

Table 1. MAC for the Crew Protection Kit - Continued.

(1) GROUP NUMBER	(2) COMPONENT/ ASSEMBLY	(3) MAINTENANCE FUNCTION	(4) MAINTENANCE LEVEL				(5) TOOLS AND EQUIPMENT REF CODE	(6) REMARKS CODE			
			FIELD		SUSTAINMENT						
			UNIT		DS	GS			DEPOT		
			C	O	F	H			D		
33	SPECIAL PURPOSE KITS - Continued	Lower Brush Guard	Inspect	0.2						A	
			Install		3.0				8,10,11,12,13		
			Replace		2.0				8,10,11,12,13		
		Louvered Grille Assembly	Inspect	0.2							A
			Install		2.0				10,13		
			Replace		2.0				13		
		Headlight Composite Light	Inspect	0.2							A
			Install		1.0				10,13		
			Replace		1.0				13		
		Blackout Drive Light	Inspect	0.2							A
			Install		1.0				10,13		
			Replace		1.0				13		
		Escape Hatch	Inspect	0.2							A
			Install		1.0				10,13		
			Replace		1.0				13		
		Roof Armor	Inspect	0.2							A
			Install		3.0				8,10,11,13		
			Replace		3.0				8,10,11,13		
		Rear Cab Armor (Right)	Inspect	0.2							A
			Install		2.0				2,8,10,11,13		
			Replace		2.0				2,8,10,11,13		
		Rear Cab Armor (Left)	Inspect	0.2							A
			Install		2.0				2,8,10,11,13		
			Replace		2.0				2,8,10,11,13		
		Right Side Blast Deflector	Inspect	0.2							A
			Install		3.0				8,10,11,12,13		
			Replace		2.0				8,10,11,12,13		
Left Side Blast Deflector	Inspect	0.2							A		
	Install		3.0				8,10,11,12,13				
	Replace		2.0				8,10,11,12,13				
Center Blast Deflector	Inspect	0.2							A		
	Install		3.0				8,10,11,12,13				
	Replace		2.0				8,10,11,12,13				

MAINTENANCE ALLOCATION CHART (MAC) - CONTINUED

0034 00

Table 1. MAC for the Crew Protection Kit - Continued.

(1) GROUP NUMBER	(2) COMPONENT/ ASSEMBLY	(3) MAINTENANCE FUNCTION	(4) MAINTENANCE LEVEL					(5) TOOLS AND EQUIPMENT REF CODE	(6) REMARKS CODE
			FIELD		SUSTAINMENT				
			UNIT		DS	GS	DEPOT		
			C	O	F	H	D		
33	SPECIALPURPOSE KITS - Continued								
	Rear Side Armor Panel (LH or RH)	Inspect	0.2						
		Install		2.0			10,13	A	
		Replace		2.0			13		
	Front Side Armor Panel (LH or RH)	Inspect	0.2						
		Install		2.0			10,13	A	
		Replace		2.0			13		
	Side Armor Panel - Model B (LH or RH)	Inspect	0.2						
		Install		4.0			8,10,11,13	A	
	Replace		4.0			8,10,11,13			

Table 2. Tools and Test Equipment Requirements for the Crew Protection Kit.

(1) TOOLS OR TEST EQUIPMENT REFERENCE CODE	(2) MAINTENANCE LEVEL	(3) NOMENCLATURE	(4) NATIONAL STOCK NUMBER (NSN)	(5) TOOL NUMBER (CAGEC)
1	O	Clamp, C: 2-1/2 In, 10 In. Size	5120-00-203-6432	5120-00-203-6432 (08292)
2	O	Dispenser, Sealant	5120-00-679-5655	101 (06798)
3	O	Drill, Electric, Portable: 1/2 In., Right Angle		DW120K (1U3E8)
4	O	Drill, Step: 1/4 to 3/4 In.	5133-01-146-4578	59003 (1JU00)
5	O	Drill, Twist: 17/32 In.	5133-00-189-9324	10034 (067J8)
6	O	Drill, Twist: 9/16 In.	5133-00-189-9326	10036 (067J8)
7	O	Drill, Twist: 5/8 In.	5133-00-266-9466	10590 (067J8)
8	O	Link, Bearing (Lifting)	5120-01-451-1401	1387575 (11083)
9	O	Screwdriver Attachment Set, Socket Wrench: Torx	5120-01-178-6342	J-29843 (33287)
10	O	Shop Equipment, Automotive Maintenance and Repair: Organizational Maintenance, Common No. 1, Less Power	4910-00-754-0654	SC 4910-95CLA74 (19204)
11	O	Sling	2835-01-078-2081	4-8FTX2IN (91796)
12	O	Stud, Threaded		107430-1 (54786)
13	O	Tool Kit, General Mechanic's: Automotive	5180-01-454-3787	12B470000 (59678)

Table 3. Remarks for the Crew Protection Kit.

(1) REMARKS CODE	(2) REMARKS
A	Refer to Operator PMCS.
B	Service by cleaning ballistic glass.

END OF WORK PACKAGE

EXPENDABLE AND DURABLE ITEMS LIST

0035 00**SCOPE**

This work package lists expendable and durable items you will need to install, operate and maintain the Crew Protection Kit. This listing is for informational purposes only and is not authority to requisition the listed items. These items are authorized to you by CTA 50-970, *Expendable/Durable Items (Except Medical, Class V, Repair Parts, and Heraldic Items)*, or CTA 8-100, *Army Medical Department Expendable/Durable Items*.

EXPLANATION OF COLUMNS

1. **Column (1) - Item Number.** This identification number is referenced in Initial Setup lists and narrative instructions in maintenance work packages [e.g., Apply sealing compound (Item , WP 0035 00)].
2. **Column (2) - Level.** This column identifies the lowest level of maintenance that requires the listed item.
 - C - Operator/Crew
 - O - Unit Maintenance
3. **Column (3) - National Stock Number.** The National Stock Number (NSN) assigned to the item to requisition it.
4. **Column (4) - Description, CAGEC, and Part Number.** Other information you need to identify the item.
5. **Column (5) - Unit of Measure (U/M).** This column shows the physical measurement or count of an item, such as gallon, dozen, gross, etc.

Table 1. Expendable and Durable Items.

(1) ITEM NUMBER	(2) LEVEL	(3) NATIONAL STOCK NUMBER	(4) DESCRIPTION, CAGEC, AND PART NUMBER	(5) U/M
1	O	8040-01-250-3969	ADHESIVE, THREAD (05972) 242 50 Milliliter Bottle	BT
2	C	6850-01-474-2318 6850-01-474-2320 6850-01-474-2321	CLEANING COMPOUND: Solvent, Type III (81349) MIL-PRF-680 1 Gallon Can 5 Gallon Can 55 Gallon Drum	CN CN DR
3	O	5350-00-584-4654	CLOTH, ABRASIVE (80204) ANSI B74.18 50 Sheet Package	PK
4	C	7930-00-282-9699 9140-00-286-5294 9140-00-286-5295 9140-00-286-5296	DETERGENT: General Purpose, Liquid (83421) 7930-00-282-9699 1 Gallon Can Bulk 5 Gallon Can 55 Gallon Drum	CN GL CN DR
5	C	9150-00-189-6727 9150-00-186-6668 9150-00-191-2772	OIL, LUBRICATING: OE/HDO-10 (81349) MIL-PRF-2104 1 Quart Can 5 Gallon Can 55 Gallon Drum	CN CN DR
6	C	7930-00-935-3794	POLISH, PLASTIC (12849) 5602261	BX
7	C	7920-00-205-1711	RAG: Wiping (64067) A-A-531 50 Pound Bale	BL
8	O	8030-01-320-4710	SEALING COMPOUND: Urethane (52157) 051135-08609 10.5 Ounce Cartridge	CA
9	O	5975-01-379-4997	STRAP, TIEDOWN: Electrical Components (06383) PLT35-C-O Package of 100	PK

Table 1. Expendable and Durable Items - Continued.

(1) ITEM NUMBER	(2) LEVEL	(3) NATIONAL STOCK NUMBER	(4) DESCRIPTION, CAGEC, AND PART NUMBER	(5) U/M
10	O	9905-00-537-8954	TAG, MARKER (64067) 9905-00-537-8954 Bundle of 50	BD
11	O	7510-00-473-9513	TAPE: Pressure Sensitive Adhesive (81349) MIL-T-23397 60 Yard Roll	RL

END OF WORK PACKAGE

SCOPE

This work package lists standard torque values and provides general information for applying torque. Special torque values and tightening sequences are indicated in the maintenance procedures for applicable components.

GENERAL

1. Always use torque values listed in Tables 1 and 2 when a maintenance procedure does not give a specific torque value.
 - a. Table 1 provides torque limits for SAE standard fasteners.
 - b. Table 2 provides torque limits for metric fasteners.
2. Unless otherwise indicated, standard torque tolerance shall be ± 10 percent.
3. Torque values listed are based on clean, dry threads. Reduce torque by 10 percent when engine oil is used as a lubricant. Reduce torque by 20 percent if new plated capscrews are used.
4. If the maintenance procedures do not specify a tightening order, use the following guides:
 - a. Unless otherwise specified, lubricate threads of fasteners with clean oil (OE/HDO-10).
 - b. When tightening fasteners above 30 lb-ft (41 Nm), use the torque pattern but only tighten to 70 percent of final value (multiply final value by 0.7). Repeat pattern until final value is reached.
 - c. Tighten circular patterns using circular torque pattern and tighten straight patterns using straight torque pattern.

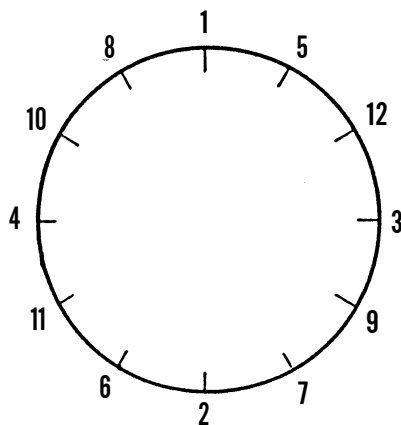

CIRCULAR TORQUE PATTERN

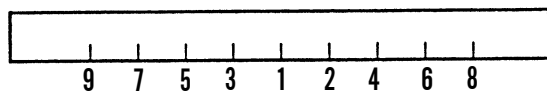

STRAIGHT TORQUE PATTERN

CAUTION

If replacement capscrews are of higher grade than originally supplied, use torque specifications for the original. This will prevent equipment damage due to overtightening.

Table 1. Torque Limits - SAE Standard Fasteners.



CURRENT USAGE	MUCH USED	MUCH USED	USED AT TIMES	USED AT TIMES
QUALITY OF MATERIAL	INDETERMINATE	MINIMUM COMMERCIAL	MEDIUM COMMERCIAL	BEST COMMERCIAL
SAE Grade Number	1 or 2	5	6 or 7	8
Capscrew Head Markings				
Manufacturer's marks may vary				
These are all SAE Grade 5 (3 line)				
CAPSCREW BODY SIZE IN. - THREAD	TORQUE LB-FT (NM)	TORQUE LB-FT (NM)	TORQUE LB-FT (NM)	TORQUE LB-FT (NM)
1/4 20 28	5 (7) 6 (8)	8 (11) 10 (14)	10 (14)	12 (16) 14 (19)
5/16 18 24	11 (15) 13 (18)	17 (23) 19 (26)	19 (26)	24 (33) 27 (37)
3/8 16 24	18 (24) 20 (27)	31 (42) 35 (47)	34 (46)	44 (60) 49 (66)
7/16 14 20	28 (38) 30 (41)	49 (66) 55 (75)	55 (75)	70 (95) 78 (106)
1/2 13 20	39 (53) 41 (56)	75 (102) 85 (115)	85 (115)	105 (142) 120 (163)
9/16 12 18	51 (69) 55 (75)	110 (149) 120 (163)	120 (163)	155 (210) 170 (231)
5/8 11 18	83 (113) 95 (129)	150 (203) 170 (231)	167 (226)	210 (285) 240 (325)
3/4 10 16	105 (142) 115 (156)	270 (366) 295 (400)	280 (380)	375 (508) 420 (569)
7/8 9 14	160 (217) 175 (237)	395 (536) 435 (590)	440 (597)	605 (820) 675 (915)
1 8 14	235 (319) 250 (339)	590 (800) 660 (895)	660 (895)	910 (1234) 990 (1342)

Table 2. Torque Limits - Metric Fasteners.

TORQUE VALUES FOR METRIC THREAD FASTENERS WITH LUBRICATED* OR PLATED THREADS†				
Thread Diameter-Pitch				
	Class 8.8 Bolt	Class 8 Nut	Class 10.9 Bolt	Class 10 Nut
	Torque: lb-ft (Nm)		Torque: lb-ft (Nm)	
M6	5 (7)		7 (9)	
M8	12 (16)		17 (23)	
M8 x 1	13 (18)		18 (24)	
M10	24 (33)		34 (46)	
M10 x 1.25	27 (37)		38 (52)	
M12	42 (57)		60 (81)	
M12 x 1.5	43 (58)		62 (84)	
M14	66 (89)		95 (129)	
M14 x 1.5	72 (98)		103 (140)	
M16	103 (140)		148 (201)	
M16 x 1.5	110 (149)		157 (213)	
M18	147 (199)		203 (275)	
M18 x 1.5	165 (224)		229 (310)	
M20	208 (282)		288 (390)	
M20 x 1.5	213 (313)		320 (434)	
M22	283 (384)		392 (531)	
M22 x 1.5	315 (427)		431 (584)	
M24	360 (488)		498 (675)	
M24 x 2	392 (531)		542 (735)	
M27	527 (715)		729 (988)	
M27 x 2	569 (771)		788 (1068)	
M30	715 (969)		990 (1342)	
M30 x 2	792 (1074)		1096 (1486)	

* All plated and unplated fasteners should be coated with oil before installation.

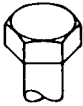
† Use these torque values if either the bolt or nut is lubricated or plated (zinc-phosphate conversion-coated, cadmium-plated, or waxed).

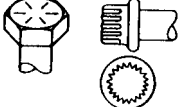
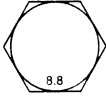
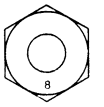
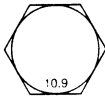
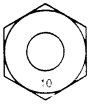
END OF WORK PACKAGE

**FIELD MAINTENANCE (UNIT AND DIRECT SUPPORT MAINTENANCE) REPAIR PARTS
LISTS (RPSTL) INTRODUCTION**

0037 00

SCOPE

This RPSTL lists and authorizes spares and repair parts required for performance of Field level maintenance of Heavy Expanded Mobility Tactical Trucks (HEMTT). It authorizes the requisitioning, issue, and disposition of spares and repair parts as indicated by the source, maintenance, and recoverability (SMR) codes.

GENERAL

In addition to the Introduction work package, this RPSTL is divided into the following work packages:

- a. **Repair Parts Lists Work Package.** Work package containing lists of spares and repair parts authorized by this RPSTL for use in the performance of maintenance. This work package also includes parts which must be removed for replacement of the authorized parts. Parts lists are composed of functional groups in ascending alphanumeric sequence, with the parts in each group listed in ascending figure and item number sequence. Repair parts kits are listed separately in their own functional group. Items listed are shown on the associated illustrations.
- b. **Special Tools List Work Package.** There are no special tools for the HEMTT Armor Kit.
- c. **Cross-Reference Indexes Work Package.** There are two cross-reference indexes in this RPSTL: National Stock Number Index and Part Number Index.

EXPLANATION OF COLUMNS IN THE REPAIR PARTS LISTS WORK PACKAGES

- a. **Item No. (Column 1).** Indicates the number used to identify items called out in the illustration.
- b. **SMR Code (Column 2).** The SMR code containing supply/requisitioning information, maintenance level authorization criteria, and disposition instruction, as shown in the following breakout:

SOURCE CODE	MAINTENANCE CODE		RECOVERABILITY CODE
XXxxx	xxXXx		xxxxX
1st two positions	3rd position	4th position	5th position
How you get an item.	Who can install, replace or use the item.	Who can do complete repair* on the item.	Who determines disposition action on an unserviceable item.

* *Complete Repair:* Maintenance capacity, capability, and authority to perform all corrective maintenance tasks of the "Repair" function in a use/user environment in order to restore serviceability to a failed item.

**FIELD MAINTENANCE (UNIT AND DIRECT SUPPORT MAINTENANCE) REPAIR PARTS
LISTS (RPSTL) INTRODUCTION - CONTINUED**

0037 00

EXPLANATION OF COLUMNS IN THE REPAIR PARTS LISTS WORK PACKAGES - CONTINUED

- (1) **Source Code.** The source code tells you how to get an item needed for maintenance, repair, or overhaul of an end item/equipment. Explanations of source codes follow:

<u>Code</u>	<u>Application/Explanation</u>
PA PB PC PD PE PF PG	<p>Stocked items; use the applicable NSN to request/requisition items with these source codes. They are authorized to the maintenance category indicated by the code entered in the third position of the SMR code.</p> <p style="text-align: center;"><i>Items coded PC are subject to deterioration.</i></p> <p>.....</p>
KD KF KB	<p>Items with these codes are not to be requested/requisitioned individually. They are part of a kit which is authorized to the maintenance level indicated in the third position of the SMR code. The complete kit must be requisitioned and applied.</p> <p>.....</p>
MO - Made at Unit/ AVUM level MF - Made at DS/AVIM Level MH - Made at GS Level ML - Made at SRA MD - Made at Depot	<p>Items with these codes are not to be requested/requisitioned individually. They must be made from bulk materiel which is identified by the part number in the DESCRIPTION AND USABLE ON CODE (UOC) column and listed in the bulk materiel group work package of the RPSTL. If the item is authorized to you by the third position of the SMR code, but the source code indicates it is made at a higher level, order the item from the higher level of maintenance.</p> <p>.....</p>
AO-Assembled by Unit/ AVUM level AF-Assembled by DS/ AVIM level AH-Assembled by GS level AL-Assembled by SRA AD-Assembled by Depot	<p>Items with these codes are not to be requested/requisitioned individually. The parts that make up the assembled item must be requisitioned or fabricated and assembled at the level of maintenance indicated by the source code. If the third position of the SMR code authorizes you to replace the item, but the source code indicates the item is assembled at a higher level, order the item from the higher level of maintenance.</p>
XA	Do not requisition an "XA" coded item. Order the next higher assembly. (Refer to NOTE below).
XB	If an item is not available from salvage, order it using the CAGEC and P/N.
XC	Installation drawings, diagrams, instruction sheets, field service drawings; identified by manufacturer's P/N.
XD	Item is not stocked. Order an XD-coded item through normal supply channels using the CAGEC and P/N given, if no NSN is available.

NOTE

Cannibalization of controlled exchange, when authorized, may be used as a source of supply for items with the above source codes, except for those source coded "XA" or those aircraft support items restricted by requirements of AR 750-1.

**FIELD MAINTENANCE (UNIT AND DIRECT SUPPORT MAINTENANCE) REPAIR PARTS
LISTS (RPSTL) INTRODUCTION - CONTINUED**

0037 00

EXPLANATION OF COLUMNS IN THE REPAIR PARTS LISTS WORK PACKAGES - CONTINUED

(2) **Maintenance Code.** Maintenance codes tell you the level(s) of maintenance authorized to use and repair support items. The maintenance codes are entered in the third and fourth positions of the SMR code as follows:

(a) Third Position. The maintenance code entered in the third position tells you the lowest maintenance level authorized to remove, replace, and use an item. The maintenance code entered in the third position will indicate authorization to one of the following levels of maintenance:

<u>Code</u>	<u>Application/Explanation</u>
C.	Crew or Operator maintenance done within Field/AVUM maintenance.
O	Unit Level/AVUM maintenance can remove, replace, and use the item.
F.	Direct Support/AVIM maintenance can remove, replace, and use the item.
H	General Support maintenance can remove, replace, and use the item.
L	Specialized Repair Activity (SRA) can remove, replace, and use the item.
D	Depot Maintenance can remove, replace, and use the item.

(b) Fourth Position. The maintenance code entered in the fourth position tells you whether or not the item is to be repaired and identifies the lowest maintenance level with the capability to do complete repair (perform all authorized repair functions).

NOTE

Some limited repair may be done on the item at a lower level of maintenance, if authorized by the Maintenance Allocation Chart (MAC) and SMR codes.

<u>Code</u>	<u>Application/Explanation</u>
O	Unit/AVUM is the lowest level that can do complete repair of the item.
F.	Direct Support/AVIM is the lowest level that can do complete repair of the item.
H	General Support is the lowest level that can do complete repair of the item.
L.	Specialized Repair Activity (SRA) is the lowest level that can do complete repair of the item.
D	Depot is the lowest level that can do complete repair of the item.
Z.	Nonreparable. No repair is authorized.
B.	No repair is authorized. No parts or special tools are authorized for the maintenance of a "B"-coded item. However, the item may be reconditioned by adjusting, lubricating, etc., at the user level.

**FIELD MAINTENANCE (UNIT AND DIRECT SUPPORT MAINTENANCE) REPAIR PARTS
LISTS (RPSTL) INTRODUCTION - CONTINUED**

0037 00

EXPLANATION OF COLUMNS IN THE REPAIR PARTS LISTS WORK PACKAGES - CONTINUED

- (3) **Recoverability Code.** Recoverability codes are assigned to items to indicate the disposition action on unserviceable items. The recoverability code is entered in the fifth position of the SMR code as follows:

<u>Code</u>	<u>Application/Explanation</u>
Z.	Nonreparable item. When unserviceable, condemn and dispose of the item at the level of maintenance shown in the third position of the SMR code.
O	Reparable item. When uneconomically repairable, condemn and dispose of the item at the Unit level maintenance.
F.	Reparable item. When uneconomically repairable, condemn and dispose of the item at Direct Support level.
H	Reparable item. When uneconomically repairable, condemn and dispose of the item at General Support level.
D	Reparable item. When beyond lower level repair capability, return to depot. Condemnation and disposal of item are not authorized below depot level.
L.	Reparable item. Condemnation and disposal of item not authorized below Specialized Repair Activity (SRA).
A	Item requires special handling or condemnation procedures because of specific reasons (e.g., precious metal content, high dollar value, critical material, or hazardous material). Refer to appropriate manuals/directives for specific instructions.

- c. **NSN - (Column 3).** The NSN for the item is listed in this column.
- d. **CAGEC (Column 4).** The Commercial and Government Entity Code (CAGEC) is a five-digit code which is used to identify the manufacturer, distributor, or Government agency/activity that supplies the item.
- e. **PART NUMBER (Column 5).** Indicates the primary number used by the manufacturer (individual, company, firm, corporation, or Government activity), which controls the design and characteristics of the item by means of its engineering drawings, specifications, standards, and inspection requirements to identify an item or range of items.

NOTE

When you use an NSN to requisition an item, the item you receive may have a different part number from the part ordered.

- f. **DESCRIPTION AND USABLE ON CODE (UOC) (Column 6).** This column includes the following information:
 - (1) The Federal item name and, when required, a minimum description to identify the item.
 - (2) P/Ns of bulk materials are referenced in this column in the line entry to be manufactured or fabricated.
 - (3) Hardness Critical Item (HCI). A support item that provides the equipment with special protection from electromagnetic pulse (EMP) damage during a nuclear attack.
 - (4) The statement END OF FIGURE appears just below the last item description in column (6) for a given figure in both the repair parts list and special tools list work packages.

**FIELD MAINTENANCE (UNIT AND DIRECT SUPPORT MAINTENANCE) REPAIR PARTS
LISTS (RPSTL) INTRODUCTION - CONTINUED**

0037 00

EXPLANATION OF COLUMNS IN THE REPAIR PARTS LISTS WORK PACKAGES - CONTINUED

- g. **QTY (Column 7).** The QTY (quantity per figure) column indicates the quantity of the item used in the breakout shown on the illustration/figure, which is prepared for a functional group, subfunctional group, group or an assembly. A “V” appearing in this column in lieu of a quantity indicates that the quantity is variable and the quantity may vary from application to application.

EXPLANATION OF CROSS-REFERENCE INDEXES WORK PACKAGE FORMAT AND COLUMNS

- a. **National Stock Number (NSN) Index Work Package.**
- (1) **STOCK NUMBER Column.** This column lists the NSN by National Item Identification Number (NIIN) sequence. The NIIN consists of the last nine digits of the NSN (i.e., NSN 5305-01-674-1467). When using this column to locate an item, ignore the first four digits of the NSN. However, the complete NSN should be used when ordering items by stock number.
 - (2) **FIG. Column.** This column lists the number of the figure where the item is identified/located. The figures are in numerical order in WP 0038 00.
 - (3) **ITEM Column.** The item number identifies the item associated with the figure listed in the adjacent FIG. column. This item is also identified by the NSN listed on the same line.
- b. **Part Number (P/N) Index Work Package.** Part numbers in this index are listed in ascending alphanumeric sequence (i.e., vertical arrangement of letter and number combination which places the first letter or digit of each group in order A through Z, followed by the numbers 0 through 9 and each following letter or digit in like order).
- (1) **PART NUMBER Column.** Indicates the P/N assigned to the item.
 - (2) **FIG. Column.** This column lists the number of the figure where the item is identified/located in the repair parts list and special tools list work packages.
 - (3) **ITEM Column.** The item number is the number assigned to the item as it appears in the figure referenced in the adjacent figure number column.

SPECIAL INFORMATION

- a. **Usable On Code (UOC).** The UOC appears in the lower left corner of the DESCRIPTION column heading. Usable on codes are shown as “UOC:” in the Description Column (justified left) on the first line under the applicable item/nomenclature. Uncoded items are applicable to all models. Identification of the UOC’s used in the RPSTL are:

<u>Code</u>	<u>Used On</u>
ARM	HEMTT

- b. **Associated Publications.** The publication(s) listed below pertain to the Heavy Expanded Mobility Tactical Trucks (HEMTT):

TM 9-2320-279 Series of Technical Manuals	HEMTT
---	-------

HOW TO LOCATE REPAIR PARTS

- a. **When National Stock Number is Known:**
- (1) **First.** If you have the NSN, look in the STOCK NUMBER column of the NSN index work package. The NSN is arranged in NIIN sequence. Note the figure and item number next to the NSN.
 - (2) **Second.** Turn to the figure and locate the item number. Verify that the item is the one you are looking for.
- b. **When Part Number is Known.**
- (1) **First.** If you have the P/N and not the NSN, look in the PART NUMBER column of the P/N index work package. Identify the figure and item number.
 - (2) **Second.** Look up the item on the figure in the applicable repair parts list work package.

**FIELD MAINTENANCE (UNIT AND DIRECT SUPPORT MAINTENANCE) REPAIR PARTS
LISTS (RPSTL) INTRODUCTION - CONTINUED**

0037 00

ABBREVIATIONS

For standard abbreviations see ASME Y14.38-1999, *Abbreviations and Acronyms*.

<u>Abbreviations</u>	<u>Explanation</u>
NIIN	National Item Identification Number (consists of the last 9 digits of the NSN)
RPSTL	Repair Parts and Special Tools Lists
SMR	Source, Maintenance, and Recoverability Code

END OF WORK PACKAGE

REPAIR PARTS AND SPECIAL TOOLS LIST

0038 00

1
2-18

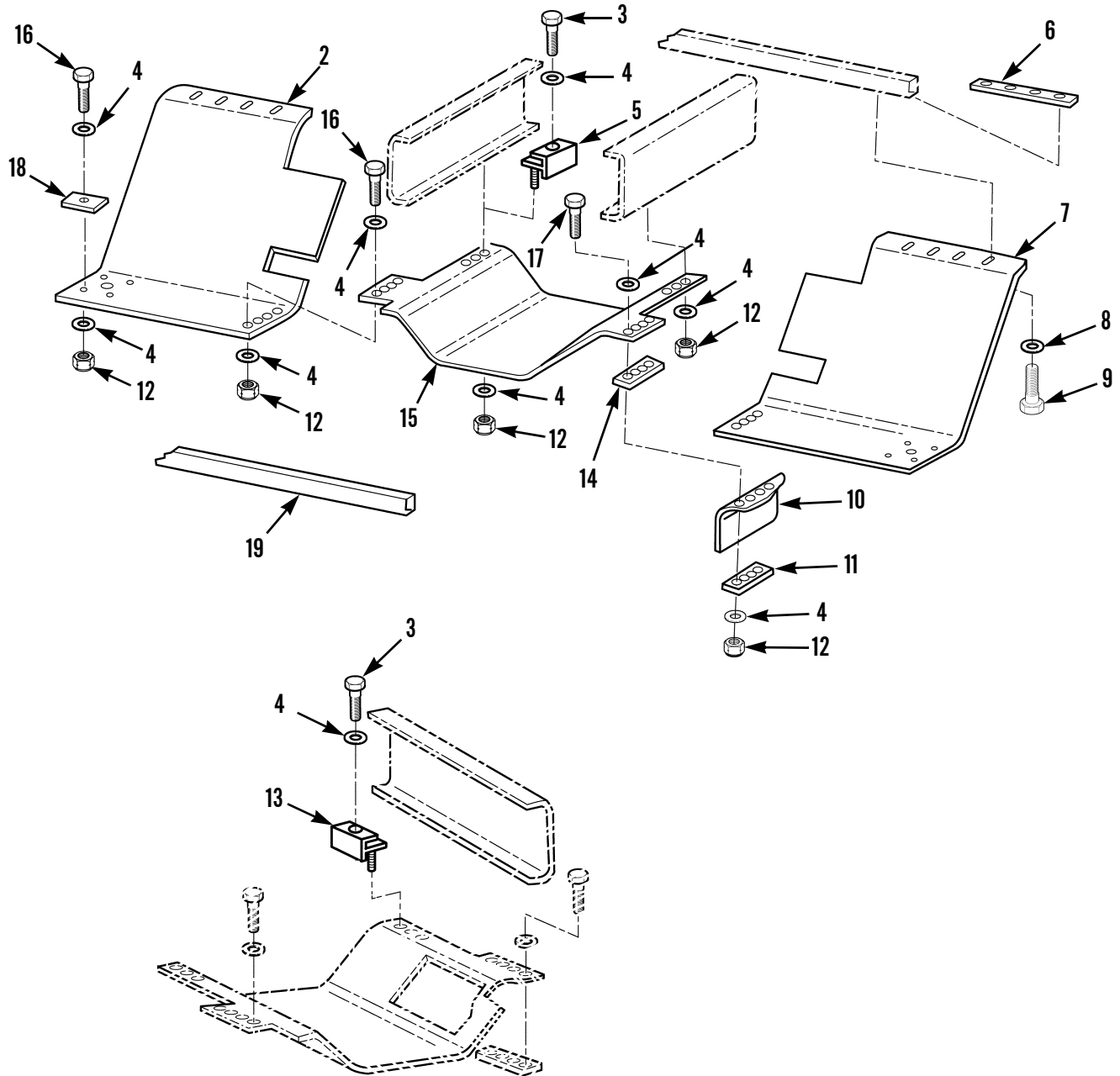

Figure 1. Underbody Armor Protection Kit

(1) ITEM NO	(2) SMR CODE	(3) NSN	(4) CAGEC	(5) PART NUMBER	(6) DESCRIPTION AND USABLE ON CODES (UOC)	(7) QTY
GROUP 33 SPECIAL PURPOSE KITS						
GROUP 3307 SPECIAL PURPOSE KITS						
FIG. 1 UNDERBODY ARMOR PROTECTION KIT						
*	1	PAOZZ 2540015265296	54786	106706-3	ARMOR SET, SUPPLEMEN.....	1
*	2	PFOZZ 2540015330549	54786	106717-2-103	.ARMOR, SUPPLEMENTAL, PASSENGER SIDE FRONT BLAST DEFLECTOR.....	1
	3	PFOZZ 5305009381539	80204	B1821BH075C200N	.SCREW, CAP, HEXAGON H 0.75-10 X 2.00	8
	4	PFOZZ 5310008098533	96906	MS27183-23	.WASHER, FLAT 0.75 ID PART OF KIT P/N 111444-1.....	38
*	5	PFOZZ 2540015328904	54786	106754-1	.ARMOR, SUPPLEMENTAL, CENTER BLAST DEFLECTOR BRACKET (PASSENGER SIDE)..	1
*	6	PFOZZ 2540015329888	54786	106778-1	.ARMOR, SUPPLEMENTAL, SIDE BLAST DEFLECTOR THREADED PLATE.....	2
*	7	PFOZZ 2540015327364	54786	106717-1	.ARMOR PLATE DRIVER'S SIDE BLAST DEFLECTOR.....	1
	8	PFOZZ 5310008095997	96906	MS27183-17	.WASHER, FLAT 0.50 ID PART OF KIT P/N 111444-1.....	8
	9	PFOZZ 5305000712069	80204	B1821BH050C150N	.SCREW, CAP, HEXAGON H 0.50-13 X 1.50	8
*	10	PFOZZ 2540015330865	54786	111458-1	.SHIELD, MINE BLAST.....	1
*	11	PFOZZ 2540015330505	54786	111493-1	.ARMOR, SUPPLEMENTAL,	1
	12	PFOZZ 5310004093333	96906	MS51943-45	.NUT, SELF-LOCKING, HE 0.75-10 PART OF KIT P/N 111444-1.....	20
*	13	PFOZZ 2540015328905	54786	106753-1	.ARMOR, SUPPLEMENTAL, CENTER BLAST DEFLECTOR BRACKET (DRIVER'S SIDE)...	1
*	14	PFOZZ 5365015330520	54786	106777-1	.SPACER, STRAIGHT BLAST DEFLECTOR SPACER.....	1
*	15	PFOZZ 2540015321831	54786	106715-1	.ARMOR PLATE CENTER BLAST DEFLECTOR	1
	16	PFOZZ 5305009227994	80204	B1821BH075C250N	.SCREW, CAP, HEXAGON H 0.750-10 X 2.50.....	6
	17	PFOZZ 5305009474360	80204	B1821BH075C450N	.SCREW, CAP, HEXAGON H 0.75-10 X 4.50 PART OF KIT P/N 111444-1.....	4
*	18	PFOZZ 2540015330493	54786	106719-1	.ARMOR, SUPPLEMENTAL, BRUSHGUARD DOUBLER.....	6
*	19	PFOZZ 2540015330508	54786	107406-1	ARMOR, SUPPLEMENTAL, PART OF KIT P/N V 106707-1.....	V

END OF FIGURE

4
5-23

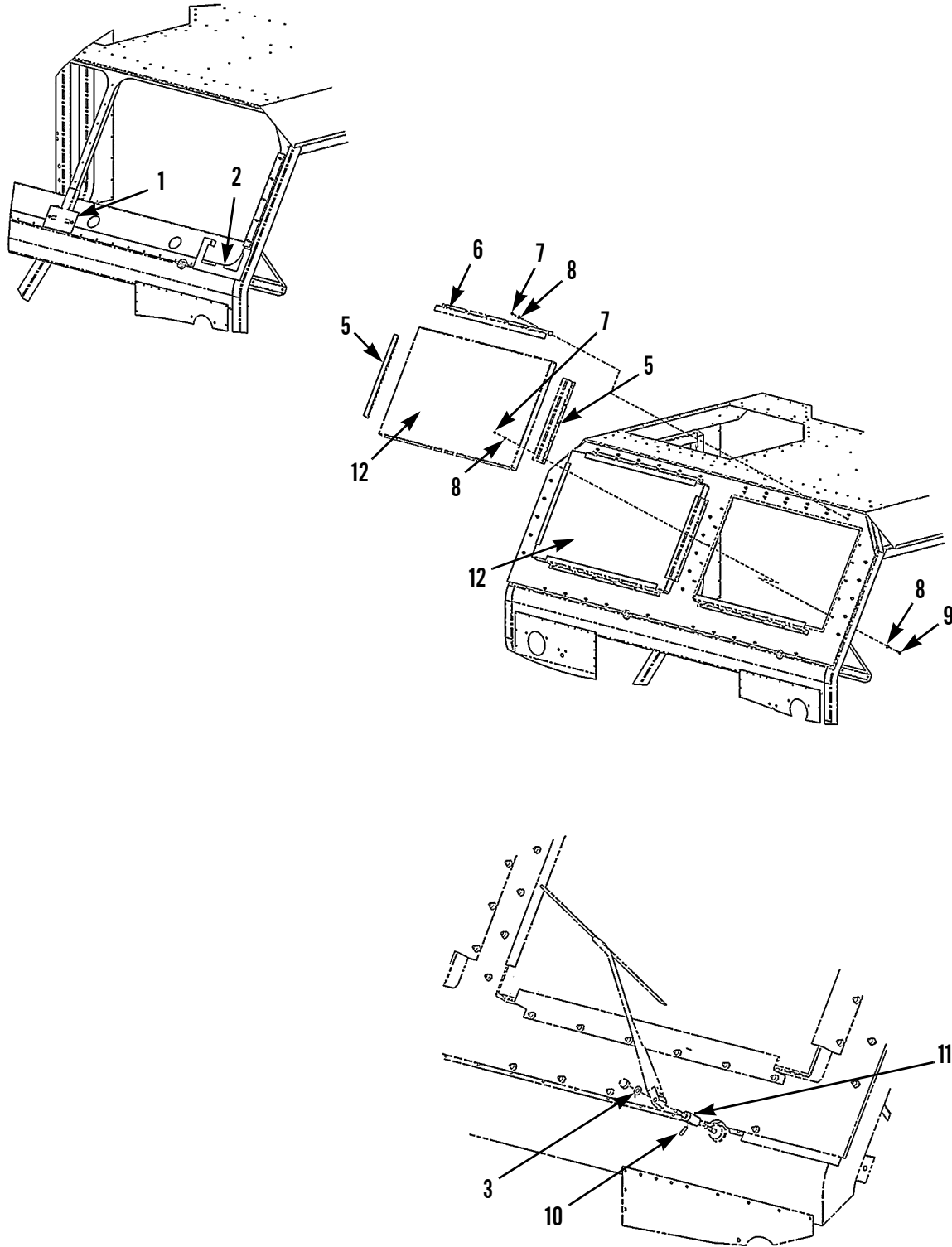

Figure 2. Windshield Armor Protection Kit (Sheet 1 of 2)

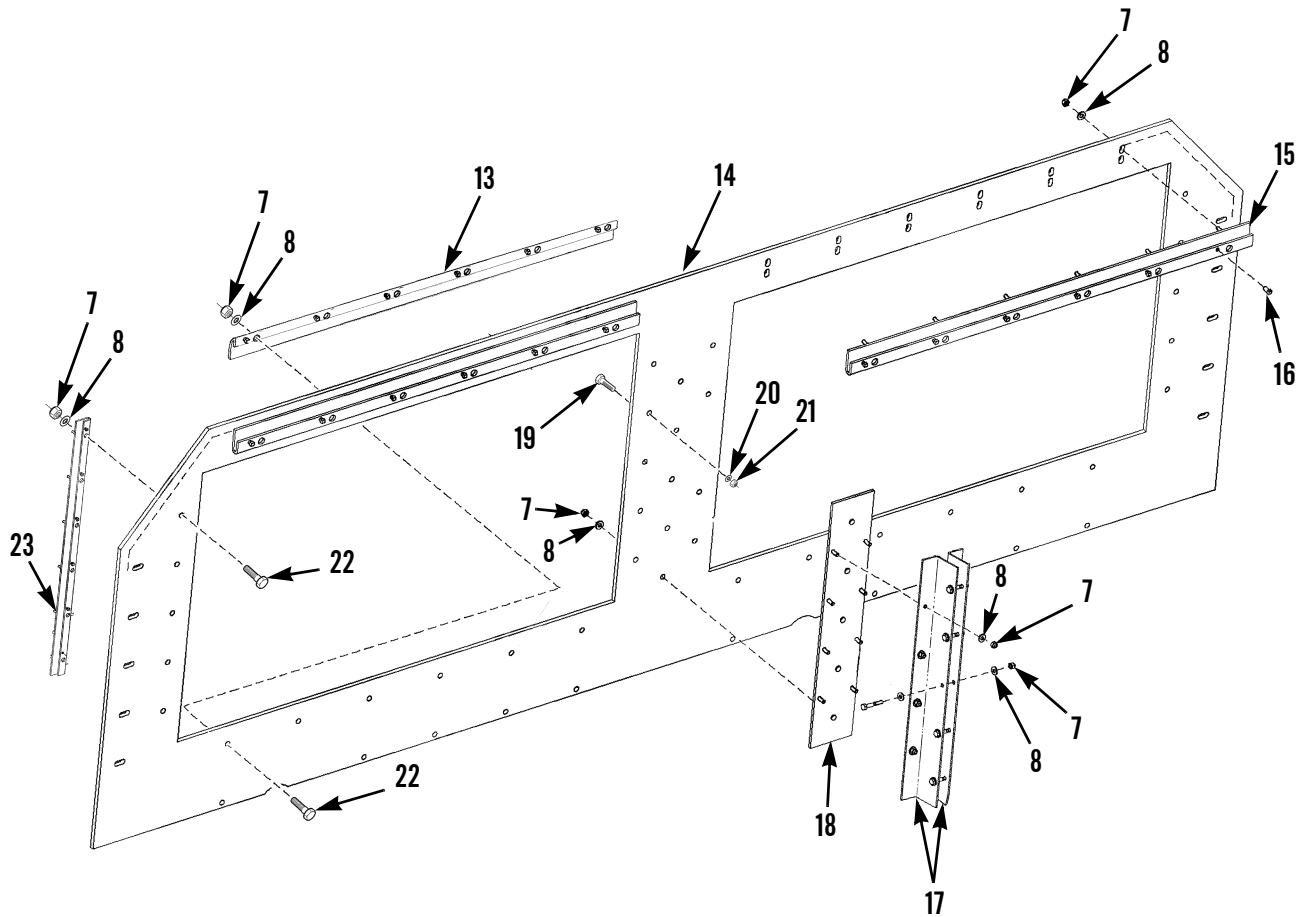

Figure 2. Windshield Armor Protection Kit (Sheet 2 of 2)

(1) ITEM NO	(2) SMR CODE	(3) NSN	(4) CAGEC	(5) PART NUMBER	(6) DESCRIPTION AND USABLE ON CODES (UOC)	(7) QTY
GROUP 3307 SPECIAL PURPOSE KITS						
FIG. 2 WINDSHIELD ARMOR PROTECTION KIT						
*	1	PFOZZ 2540015330868	54786	107405-2	TEMPLATE,ARMOR WINDSHIELD ARMOR PART OF KIT P/N 106707-1.....	
*	2	PFOZZ 3465015319566	54786	107405-1	GUIDE,DRILL WINDSHIELD ARMOR PART OF KIT P/N 106707-1.....	V
	3	PFOZZ 5310001800277	80205	MS35333-76	WASHER,LOCK.....	1
	4	PAOZZ 2540015251204	54786	106701-4	ARMOR SET,SUPPLEMEN WINDSHIELD PROTECTION.....	1
*	5	PFOZZ 2590015317282	54786	113383-3-103	.BRACKET,VEHICULAR C WINDSHIELD....	4
*	6	PFOZZ 2590015320269	54786	113383-1-103	.BRACKET,VEHICULAR C WINDSHIELD....	4
*	7	PFOZZ 5310000614650	45152	114356A	.NUT,SELF-LOCKING,HE 0.25-20 PART OF KIT P/N 111444-1.....	96
*	8	PFOZZ 5310002858124	96906	MS27183-50	.WASHER,FLAT 0.25 ID PART OF KIT P/N 111444-1.....	133
	9	PFOZZ 5305002253843	80204	B1821BH025C100N	.SCREW,CAP,HEXAGON H 0.250-20 X 1.00 PART OF KIT P/N 111444-1.....	32
*	10	PFOZZ 5305015329127	54786	103255CFP-019003	.SETSCREW.....	2
				1		
*	11	PFOZZ 3040015326610	54786	111408-1	.EXTENSION,SHAFT WINDSHIELD WIPER..	2
*	12	PFOZZ 2540015307355	54786	113381-1	.ARMOR SET,SUPPLEMEN.....	2
*	13	PFOZZ 2540015339230	54786	106734-1-103	.ARMOR,SUPPLEMENTAL, BRACKET, WINDOW RETAINER.....	2
	13	PFOZZ 2590015315106	54786	106734-5-103	.BRACKET,VEHICULAR C WINDOW RETAINER (ALTERNATE PART NUMBER)....	2
*	14	PFOZZ 2510015317235	54786	106721-1-103	.FRAME,WINDOW,VEHICU WINDSHIELD FRAME.....	1
*	15	PFOZZ 2540015339242	54786	106734-2-103	.ARMOR,SUPPLEMENTAL, BRACKET, WINDOW RETAINER, TOP.....	2
*	15	PFOZZ 2590015320577	54786	106734-6-103	.BRACKET,VEHICULAR C.....	2
	16	PFOZZ 5305000712510	80204	B1821BH025C175N	.SCREW,CAP,HEXAGON H 0.250-20 X 1.75.....	5
*	17	PFOZZ 2590015330551	54786	106746-1-103	.BRACKET,VEHICULAR C WINDSHIELD "L" BRACKET.....	2
*	18	PFOZZ 2540015330547	54786	106733-1-103	.ARMOR,SUPPLEMENTAL, WINDSHIELD STUD PLATE.....	1
*	19	PFOZZ 5306015321851	54786	106795-2	.BOLT,EYE.....	2
	20	PFOZZ 5310000806004	96906	MS27183-14	.WASHER,FLAT 0.375 ID PART OF KIT P/N 111444-1.....	2
	21	PFOZZ 5310009359021	96906	MS51943-35	.NUT,SELF-LOCKING,HE 0.375-16 PART OF KIT P/N 111444-1.....	2
*	22	PFOZZ 5305000680508	80204	B1821BH025C075N	.SCREW,CAP,HEXAGON H 0.25-20 X 0.75	34
*	23	PFOZZ 2540015328866	54786	106734-3-103	.ARMOR,SUPPLEMENTAL, BRACKET, WINDOW RETAINER, SIDE.....	2

(1)	(2)	(3)	(4)	(5)	(6)	(7)	
ITEM	SMR			PART			
NO	CODE	NSN	CAGEC	NUMBER	DESCRIPTION AND USABLE ON CODES (UOC)	QTY	
*	23	PFOZZ	2590015321423	54786	106734-7-103	.BRACKET,VEHICULAR C WINDOW RETAINER,SIDE (ALTERNATE PART NUMBER).....	2

END OF FIGURE

1	13
2-9	14-21

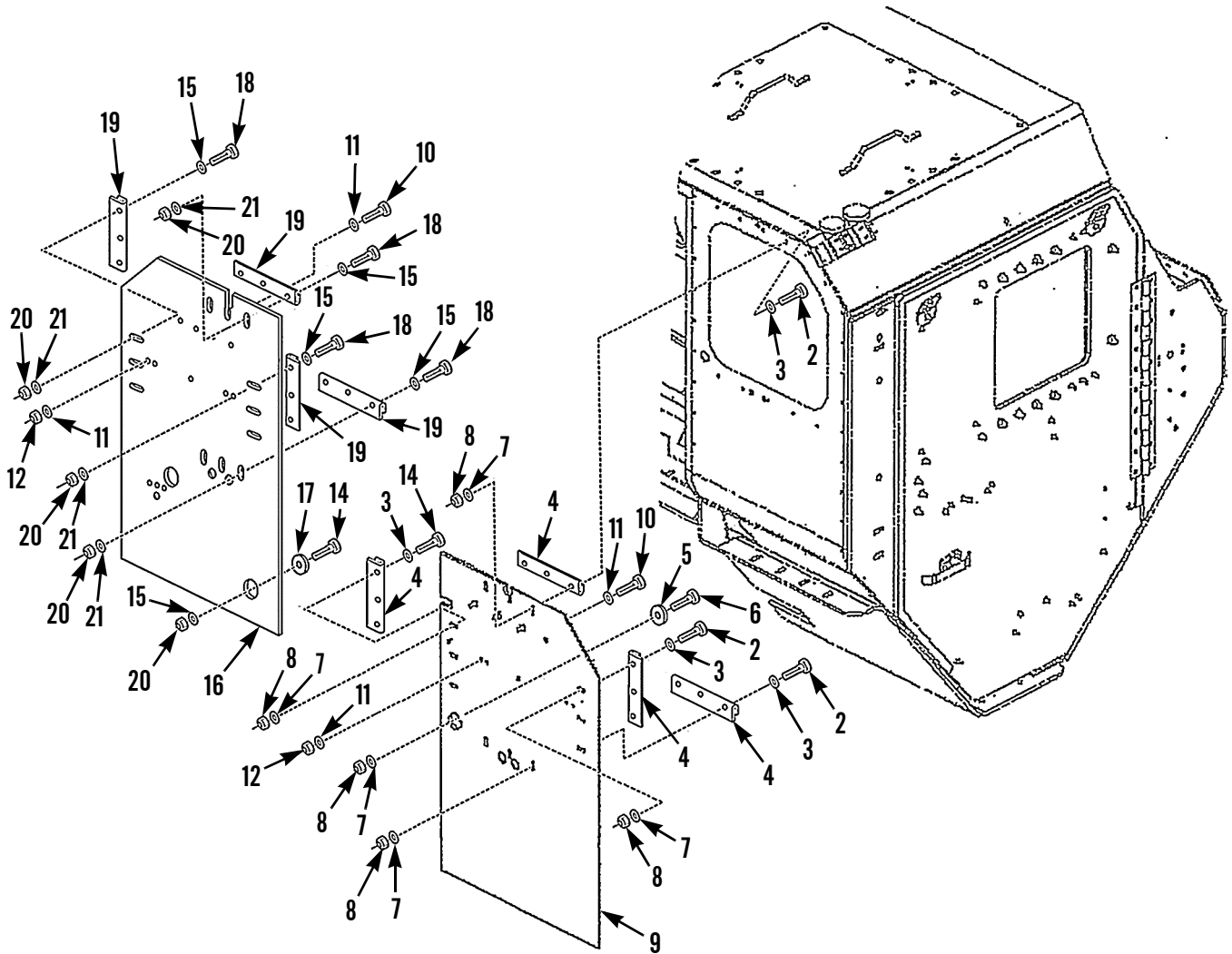

Figure 3. Rear Cab Armor Protection Kit

(1) ITEM NO	(2) SMR CODE	(3) NSN	(4) CAGEC	(5) PART NUMBER	(6) DESCRIPTION AND USABLE ON CODES (UOC)	(7) QTY
GROUP 3307 SPECIAL PURPOSE KITS						
FIG. 3 REAR CAB ARMOR PROTECTION KIT						
1	PAOZZ	2540015265303	54786	106702-4	ARMOR SET, SUPPLEMEN REAR CAB.....	1
2	PFOZZ	5305000680508	80204	B1821BH025C075N	.SCREW, CAP, HEXAGON H 0.250-20 X 0.750.....	12
*	3	PFOZZ	5310006858308	80063 104-1S12M	.WASHER, FLAT 0.250 ID PART OF KIT P/N 111444-1.....	14
	4	PFOZZ		54786 106734-4	.BRACKET, MOUNTING WINDSHIELD.....	4
*	5	PFOZZ	5310015322541	54786 111403-1	.WASHER, ARMORED.....	2
	6	PFOZZ	5305000680509	80204 B1821BH025C125N	.SCREW, CAP, HEXAGON H.....	1
	7	PFOZZ	5310000806004	96906 MS27183-14	.WASHER, FLAT 0.375 ID PART OF KIT P/N 111444-1.....	13
*	8	PFOZZ	5310000614650	45152 114356A	.NUT, SELF-LOCKING, HE 0.250-20 PART OF KIT P/N 111444-1.....	13
*	9	PFOZZ	2540015328088	54786 106724-4	.ARMOR, SUPPLEMENTAL, REAR CAB ARMOR PANEL.....	1
	10	PFOZZ	5305002253843	80204 B1821BH025C100N	SCREW, CAP, HEXAGON H 0.25-20 X 1.00 PART OF KIT P/N 111444-1.....	5
*	11	PFOZZ	5310005825965	80063 104-1S12M	WASHER, FLAT 0.25 ID.....	28
*	12	PFOZZ	5310000614650	45152 114356A	NUT, SELF-LOCKING, HE 0.187-24.....	20
	13	PAOZZ	2540015265300	54786 106702-3	ARMOR SET, SUPPLEMEN REAR CAB.....	1
*	14	PFOZZ	5305000712509	80204 B1821BH025C150N	.SCREW, CAP, HEXAGON H 0.250-20 X 1.50	2
*	15	PAOZZ	5325015265340	54786 111444-1	.FASTENER KIT, EXTRA 0.250 ID PART OF KIT P/N 111444-1.....	1
*	16	PFOZZ	2540015329885	54786 106724-3	.ARMOR, SUPPLEMENTAL, REAR CAB ARMOR PANEL.....	1
*	17	PFOZZ	5310015322541	54786 111403-1	.WASHER, ARMORED.....	2
	18	PFOZZ	5305000680508	80204 B1821BH025C075N	.SCREW, CAP, HEXAGON H 0.250-20 X 0.750.....	12
	19	PFOZZ		54786 106734-4	.BRACKET, MOUNTING ARMOR MOUNTING BRACKET.....	4
*	20	PFOZZ	5310000614650	45152 114356A	.NUT, SELF-LOCKING, HE 0.250-20 PART OF KIT P/N 111444-1.....	14
	21	PFOZZ	5310000806004	96906 MS27183-14	.WASHER, FLAT 0.375 ID PART OF KIT P/N 111444-1.....	14

END OF FIGURE

1
2-34

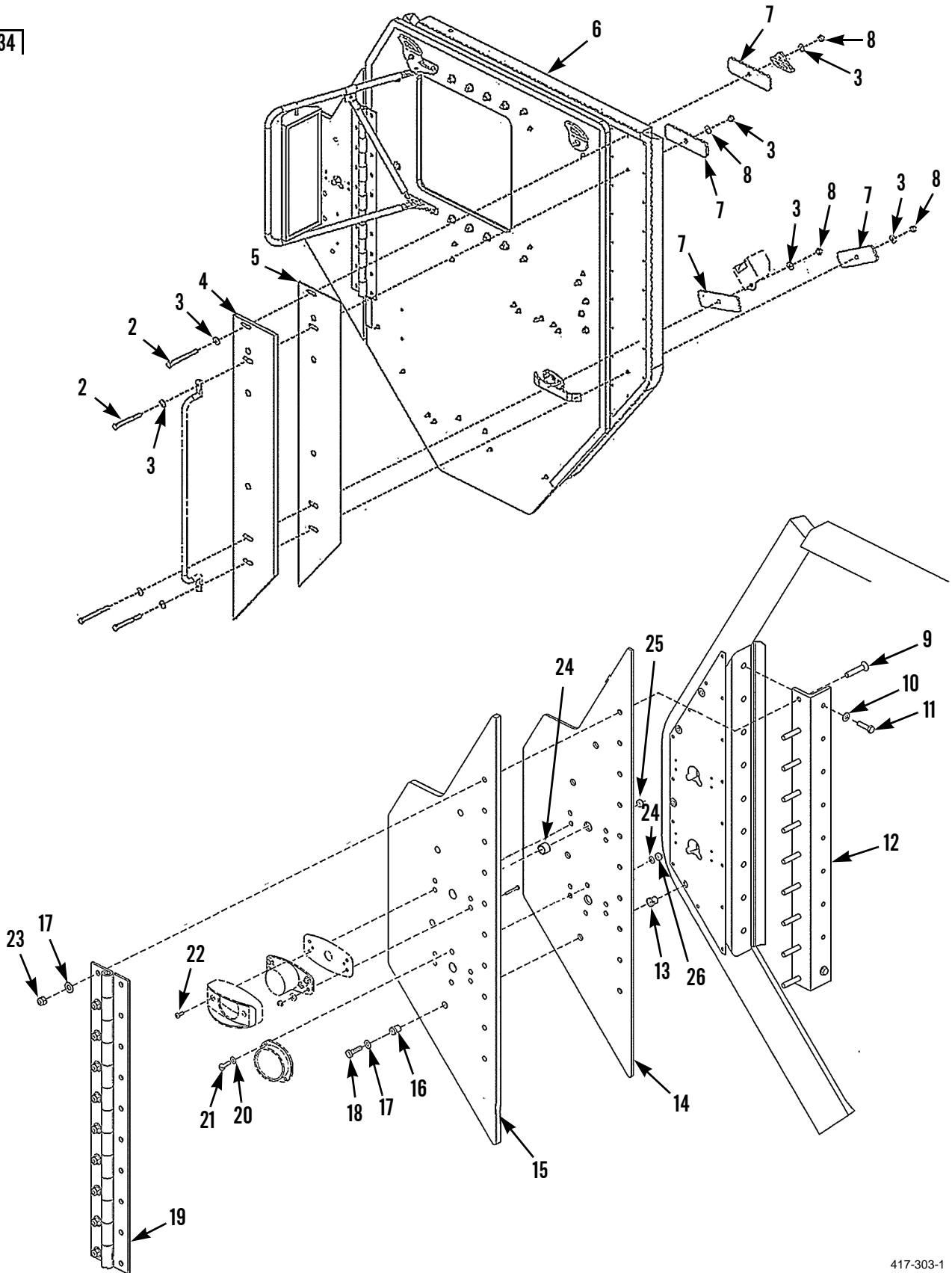

Figure 4. Side Armor Kit, Left and Right Sides (Sheet 1 of 2)

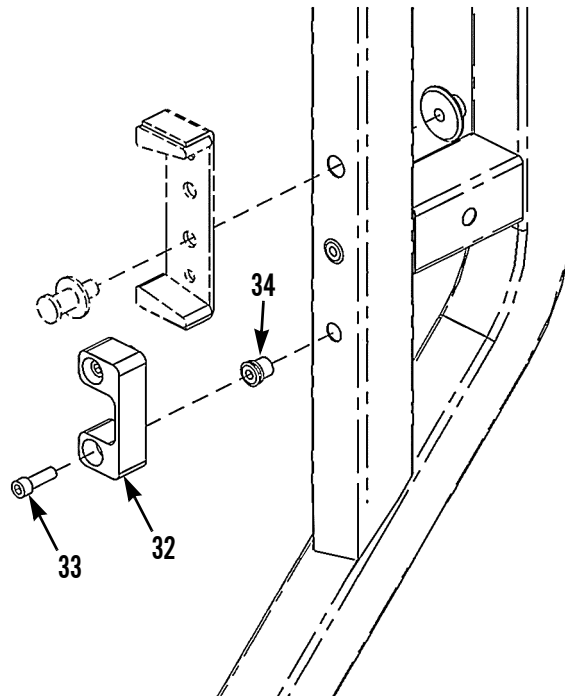
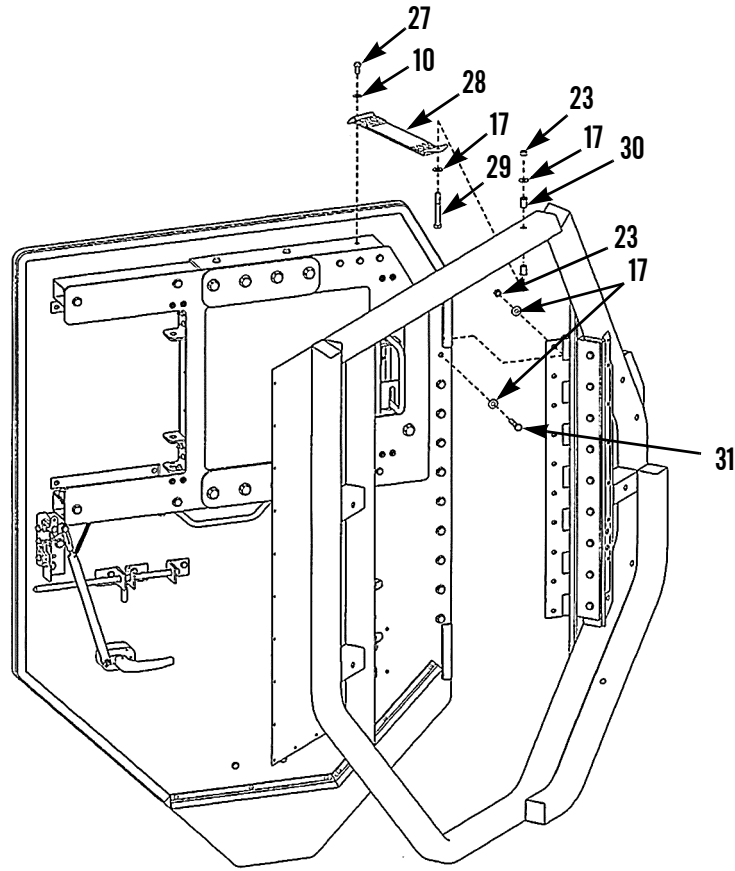

Figure 4. Side Armor Kit, Left and Right Sides (Sheet 2 of 2)

(1) ITEM NO	(2) SMR CODE	(3) NSN	(4) CAGEC	(5) PART NUMBER	(6) DESCRIPTION AND USABLE ON CODES (UOC)	(7) QTY
GROUP 3307 SPECIAL PURPOSE KITS						
FIG. 4 SIDE ARMOR KIT, LEFT AND RIGHT SIDES						
*	1	PAOZZ 2540015251203	54786	106703-9	ARMOR SET,SUPPLEMEN LEFT SIDE.....	1
	1	PAOZZ 2540015251202	54786	106703-10	ARMOR SET,SUPPLEMEN RIGHT SIDE.....	1
	2	PFOZZ	10001	3176207-C-216	.SCREW,CAP SOCKET HE 0.437-14 X 4.00.....	4
	3	PFOZZ 5310001770973	19207	11609221	.WASHER,FLAT 0.437 ID PART OF KIT P/N 111444-1.....	9
*	4	PFOZZ 2540015329883	54786	106729-5	.ARMOR,SUPPLEMENTAL, CAB ARMOR, REAR PANEL.....	1
*	5	PFOZZ 2540015330497	54786	106729-3	.ARMOR,SUPPLEMENTAL, REAR PANEL....	1
*	6	PFOZZ 2540015330492	54786	111430-1-103	.ARMOR,SUPPLEMENTAL,.....	1
*	6	PFOZZ 2540015328103	54786	111430-2-103	.ARMOR,SUPPLEMENTAL, RH.....	1
*	7	PFOZZ 2540015328901	54786	113316-1	.ARMOR,SUPPLEMENTAL,.....	4
*	8	PFOZZ 5310002416659	81349	M45913/3-7CG8C	.NUT,SELF-LOCKING,HE 0.437-14.....	5
	9	PFOZZ 5305011262322	80205	MS24667-56	.SCREW,CAP,SOCKET HE 0.375-16 X 2.0 PART OF KIT P/N 111444-1.....	10
*	10	PFOZZ 5310000097682	19207	7535871	.WASHER,FLAT 0.31 ID PART OF KIT P/N 111444-1.....	22
	11	PFOZZ 5305002264831	80204	B1821BH031C150N	.SCREW,CAP,HEXAGON H PART OF KIT P/N 111444-1.....	10
*	12	PFOZZ 2590015317232	54786	113314-1-103	.BRACKET,VEHICULAR C.....	1
*	13	PFOZZ 5365015330222	54786	113318-1	.SPACER,RING.....	4
*	14	PFOZZ 2540015328101	54786	111432-3	.ARMOR,SUPPLEMENTAL, CAB ARMOR, FRONT PANEL.....	1
*	15	PFOZZ 2540015328868	54786	111432-1	.ARMOR,SUPPLEMENTAL, FRONT PANEL...	1
	16	PFOZZ 5325014837480	78276	ALS4-616-150	.INSERT,SCREW THREAD 0.375-16 PART OF KIT P/N 111444-1.....	4
	17	PFOZZ 5310000806004	96906	MS27183-14	.WASHER,FLAT 0.375 ID PART OF KIT P/N 111444-1.....	44
*	18	PFOZZ 5305007829489	80204	B1821BH038C200N	.SCREW,CAP,HEXAGON H 0.375-16 X 2.00.....	4
*	19	PFOZZ 2510015327384	54786	113313-1	.HINGE,DOOR.....	1
	20	PFOZZ 5310005825965	80063	104-1S12M	.WASHER,LOCK 1/4 ID PART OF KIT P/N 111444-1.....	10
	21	PFOZZ 5305000712506	80204	B1821BH025C050N	.SCREW,CAP,HEXAGON H 0.25-20 X 0.50	2
	22	PFOZZ 5305009846213	80205	MS35457-28	.SCREW,CAP,SOCKET HE.....	4
	23	PFOZZ 5310009359021	96906	MS51943-35	.NUT,SELF-LOCKING,HE 3/8-16 PART OF KIT P/N 111444-1.....	25
*	24	PFOZZ 5325015322185	54786	111453-1	.GROMMET,NONMETALLIC.....	1
	25	PFOZZ 5310009349760	80205	MS35649-204	.NUT,PLAIN,HEXAGON 0.190-24.....	4
*	26	PFOZZ 5310000614650	45152	114356A	.NUT,SELF-LOCKING,HE PART OF KIT P/N 111444-1.....	2
	27	PFOZZ 5306002264825	80204	B1821BH031C075N	.BOLT,MACHINE 0.312-18 X 0.750 PART OF KIT P/N 111444-1.....	2

(1)	(2)	(3)	(4)	(5)	(6)	(7)
ITEM	SMR			PART		
NO	CODE	NSN	CAGEC	NUMBER	DESCRIPTION AND USABLE ON CODES (UOC)	QTY
*	28	PFOZZ 5340015325381	54786	113386-1	.STRAP,RETAINING.....	1
*	29	PFOZZ 5305008465703	80204	B1821BH038C300N	.SCREW,CAP,HEXAGON H 0.375-16 X 3.00.....	3
*	30	PFOZZ 3120015325228	54786	111411-1	.BUSHING,SLEEVE.....	2
	31	PFOZZ 5305007252317	80204	B1821BH038C150N	.SCREW,CAP,HEXAGON H 0.375-16 X 1.50.....	14
	32	PFOZZ 5340015315029	54786	113327-1	.PLATE,MOUNTING STRIKER.....	1
	33	PFOZZ 5305000341212	10001	1611203PC15	.SCREW,CAP,SOCKET HE 0.312-18 X 1.00.....	2
	34	PFOZZ 5310014133276	78276	ALS4-518-150	.NUT,PLAIN,BLIND RIV 0.312-18 PART OF KIT P/N 111444-1.....	3

END OF FIGURE

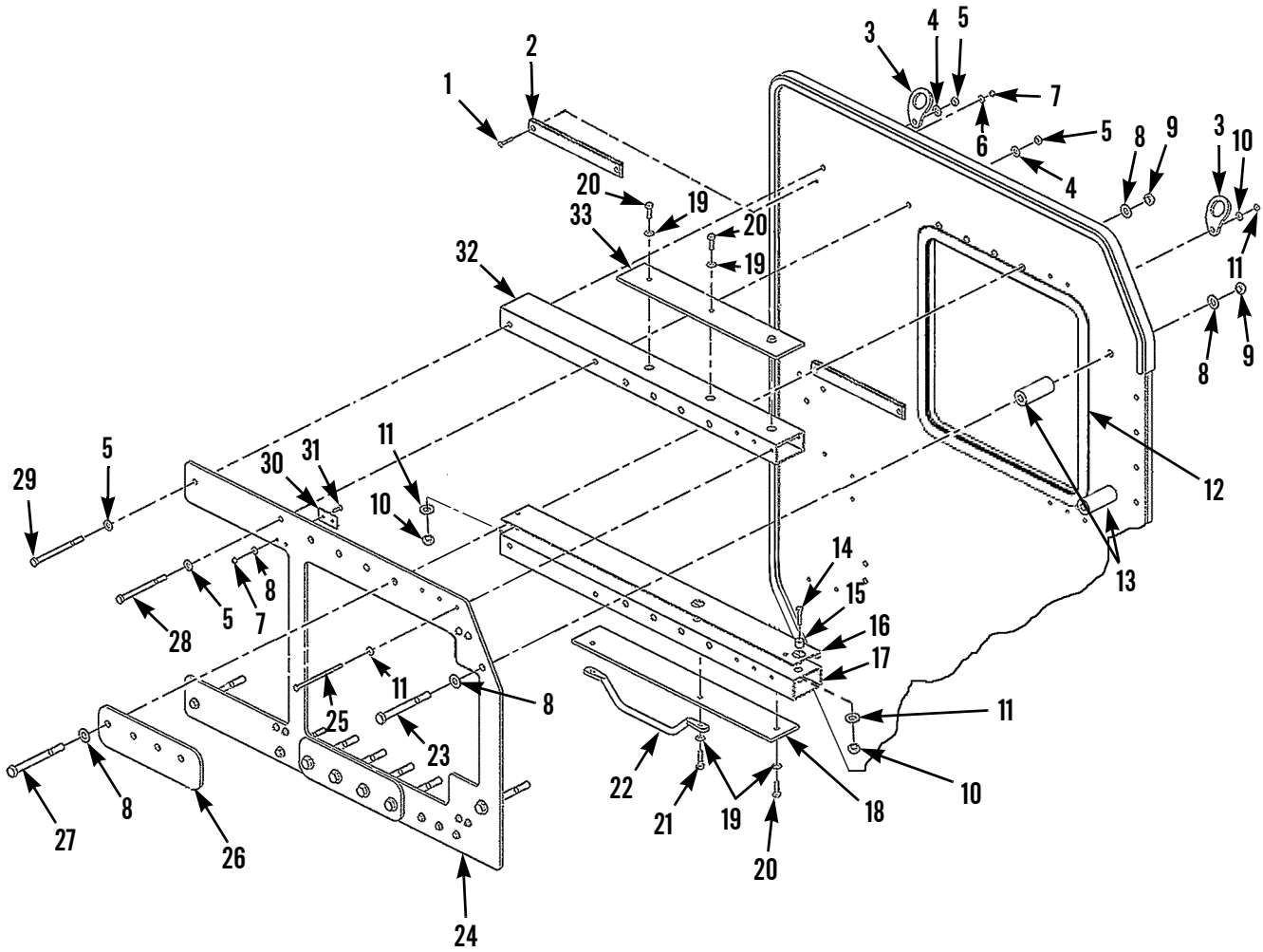

Figure 5. Armored Door Assembly, Left and Right Sides (Model A) (Sheet 1 of 3)

35
36-37

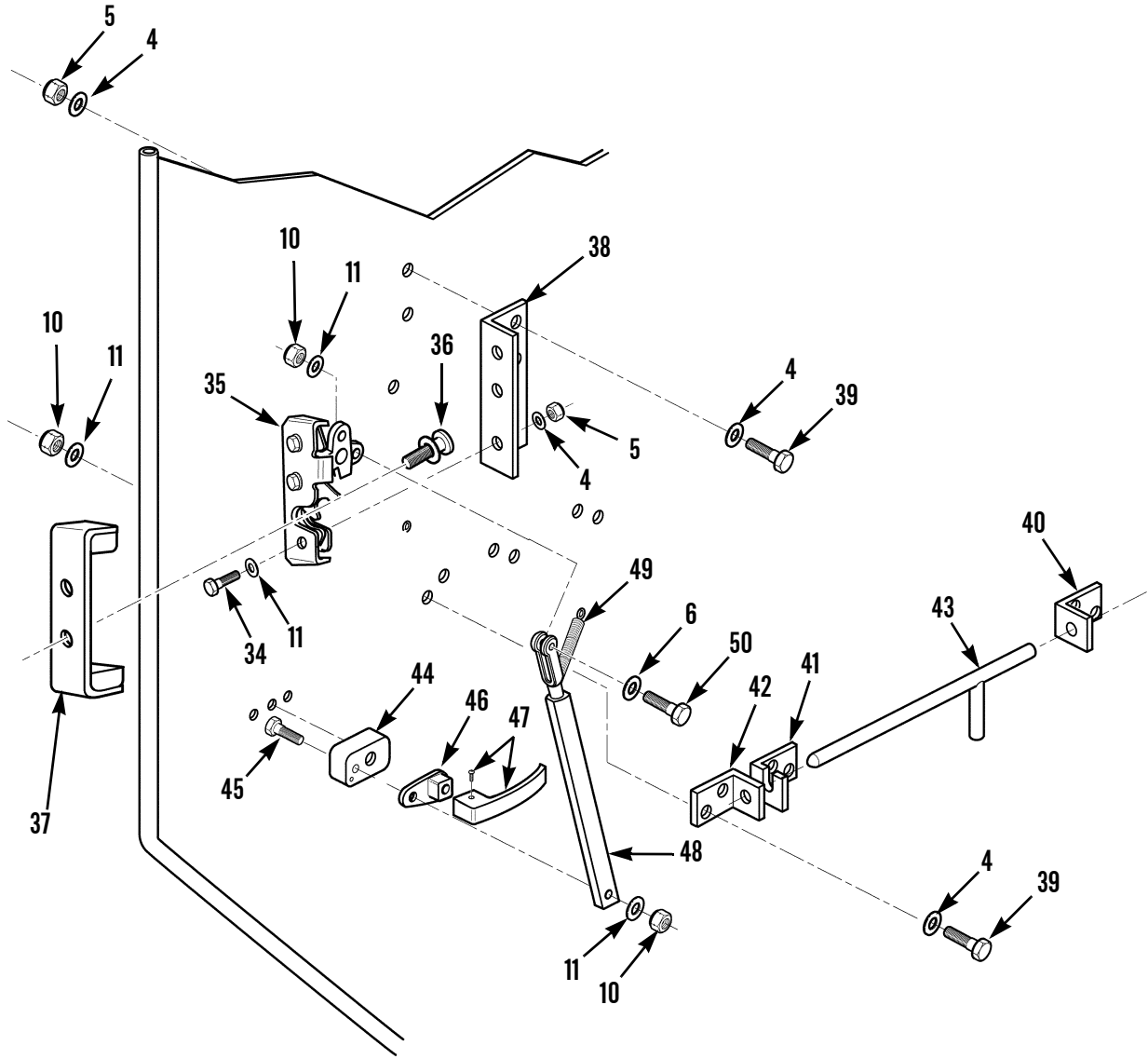

Figure 5. Armored Door Assembly, Left and Right Sides (Model A) (Sheet 2 of 3)

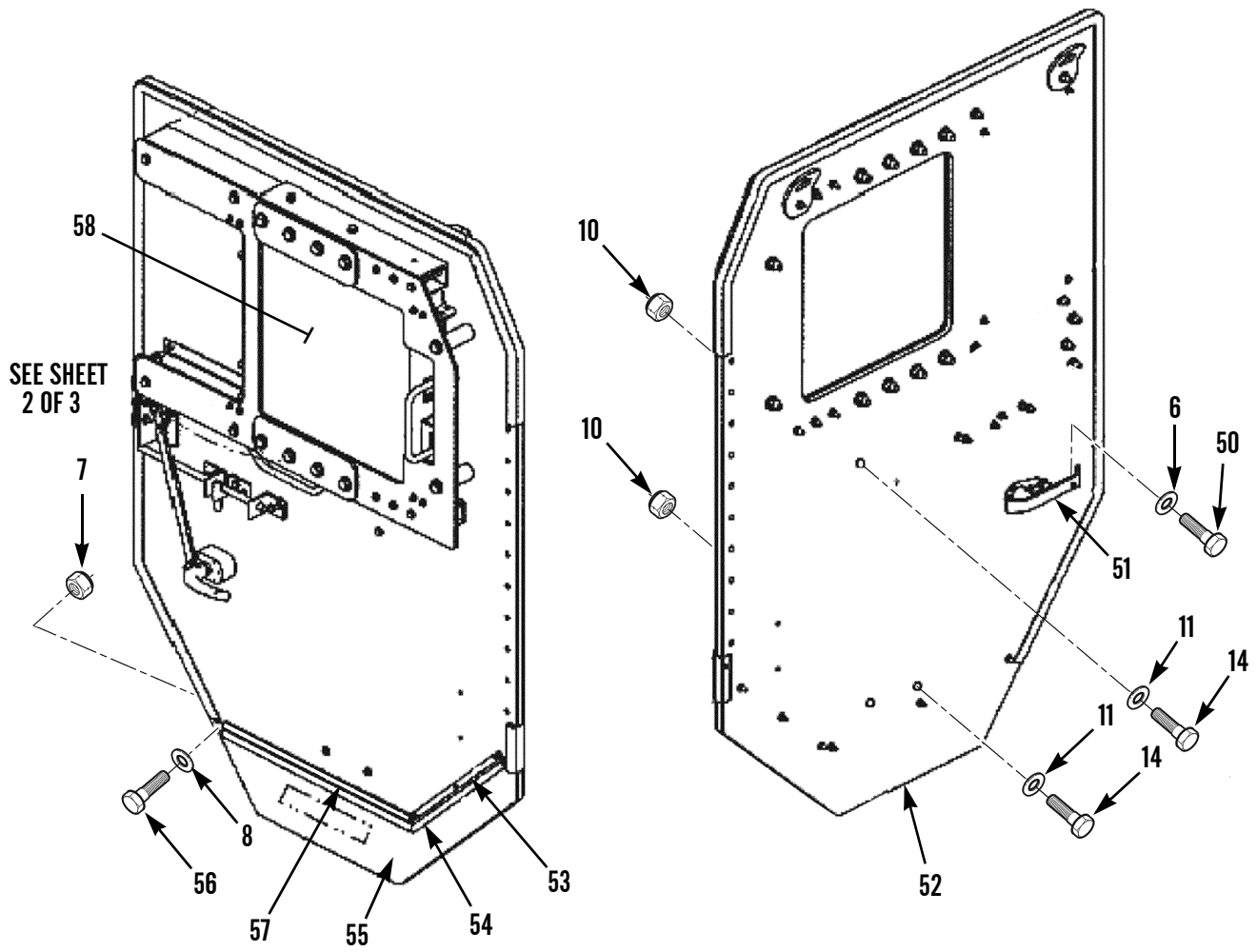

Figure 5. Armored Door Assembly, Left and Right Sides (Model A) (Sheet 3 of 3)

(1) ITEM NO	(2) SMR CODE	(3) NSN	(4) CAGEC	(5) PART NUMBER	(6) DESCRIPTION AND USABLE ON CODES (UOC)	(7) QTY
GROUP 3307 SPECIAL PURPOSE KITS						
FIG. 5 ARMORED DOOR ASSEMBLY, LEFT AND RIGHT SIDES - MODEL A						
*	1	PFOZZ 5305000227242	96906	MS35249-75	SCREW, MACHINE 0.190-24 X 1.250 PART OF KIT P/N 111444-1.....	4
*	2	PFOZZ 5365015330525	54786	113338-3	SPACER, PLATE.....	2
*	3	PFOZZ 2590015330188	54786	113354-1-103	BRACKET, VEHICULAR C.....	2
	4	PFOZZ 5310011013374	80063	SM-C-617837-2	WASHER, FLAT 0.375 ID X 0.44 THK....	14
*	5	PFOZZ 5310001834421	82458	WLA3816GRB	NUT, SELF-LOCKING, HE 0.375-15.....	7
	6	PFOZZ 5310011109790	18876	12294116-1	WASHER, FLAT 0.190 ID X 0.44 THK....	22
*	7	PFOZZ 5310014151314	80205	MS17829Z3C	NUT, SELF-LOCKING, HE 0.190-24.....	18
	8	PFOZZ 5310011124390	13499	542-1564-003	WASHER, FLAT 0.50 X 0.78 THK.....	20
	9	PFOZZ 5310000443339	19207	443339	NUT, SELF-LOCKING, HE 0.50-13.....	10
	10	PFOZZ 5310000145847	80063	SM-D-450462-4	NUT, SELF-LOCKING, HE 0.25-20.....	23
	11	PFOZZ 5310001060535	80063	104-1S12M	WASHER, FLAT 0.25 ID X 0.45 THK....	43
	12	PFOZZ 5330015319639	54786	113337-1	SEAL, NONMETALLIC SP.....	1
*	13	PFOZZ 5365015322251	54786	113317-1	SPACER, SLEEVE.....	2
	14	PFOZZ 5305000712509	80204	B1821BH025C150N	SCREW, CAP, HEXAGON H 0.25-20 X 1.5..	7
*	15	PFOZZ 5365015322111	54786	8060R D.51	SPACER 0.281 ID X 0.625 OD X 0.50..	2
	16	PFOZZ 2540015315026	54786	113328-1	ARMOR, SUPPLEMENTAL,.....	1
	17	PFOZZ 2510015315993	54786	113389-1	FRAME SECTION, WINDO LH.....	1
	17	PFOZZ 2590015317198	54786	113389-2	BRACKET, VEHICULAR C RH.....	1
	18	PFOZZ 2590015315146	54786	113387-5	BRACKET, VEHICULAR C.....	1
*	19	PFOZZ 5310001060535	57712	72579	WASHER, FLAT 0.312 ID X 0.045 THK...	5
	20	PFOZZ 5306002264827	80204	B1821BH031C100N	BOLT, MACHINE 0.31-18 X 1.00.....	3
	21	PFOZZ 5306002264829	80204	B1821BH031C125N	BOLT, MACHINE 0.312-18 X 1.25 PART OF KIT P/N 111444-1.....	2
*	22	PFOZZ 5340015326723	27182	31-8BLK	HANDLE, INSIDE, DOOR.....	1
	23	PFOZZ 5305000712083	80204	B1821BH050C500N	SCREW, CAP, HEXAGON H 0.500-13 X 5.00	2
*	24	PFOZZ 5340015329226	54786	113388-1	COVER STRIP.....	1
	25	PFOZZ 5305000712522	80204	B1821BH025C475N	SCREW, CAP, HEXAGON H PART OF KIT P/N 111444-1.....	6
	26	PFOZZ 2590015315145	54786	113387-1	BRACKET, VEHICULAR C.....	2
	27	PFOZZ 5306005544767	1TUY2	8288	BOLT, MACHINE 0.500-13 X 5.25.....	8
	28	PFOZZ 5305007813930	80204	B1821BH038C475N	SCREW, CAP, HEXAGON H 0.375-16 X 4.75 PART OF KIT P/N 111444-1.....	3
	29	PFOZZ 5305009640503	80204	B1821BH038C500N	SCREW, CAP, HEXAGON H 0.375-16 X 5.00	1
*	30	PFOZZ 5365015330924	54786	113338-1	SPACER, PLATE.....	4
	31	PFOZZ 5305000120620	96906	MS35241-72	SCREW, MACHINE 0.190-24 X 0.750.....	8
*	32	PFOZZ 2590015317198	54786	113389-2	SUPPORT, WINDOW, DOOR LH.....	1
	32	PFOZZ 2590015314966	54786	113389-4	BRACKET, VEHICULAR C RH.....	1
*	33	PFOZZ 2590015321054	54786	113387-3	BRACKET, VEHICULAR C.....	1
	34	PFOZZ 5305000680509	80204	B1821BH025C125N	SCREW, CAP, HEXAGON H 0.250-20 X 1.25	9
*	35	XDOZZ	19220	9D-400-UL	LATCH, DOOR, VEHICULA LH.....	1
*	35	PFOZZ 2540015327768	54786	9D-400URZINC	LATCH, DOOR, VEHICULA RH.....	1
*	36	PFOZZ 5340013650250	0FW39	12485124	.STRIKE, CATCH.....	1

(1) ITEM NO	(2) SMR CODE	(3) NSN	(4) CAGEC	(5) PART NUMBER	(6) DESCRIPTION AND USABLE ON CODES (UOC)	(7) QTY
*	37 PFOZZ	5340015127409	19220	D-400-53	.STRIKE, CATCH.....	1
*	37		19220	D400-53	.STRIKE, CATCH.....	1
*	38 PFOZZ	2590015315177	54786	113324-1	BRACKET, VEHICULAR C LEFT SIDE.....	1
*	38 PFOZZ	2590015320241	54786	113324-2	BRACKET, VEHICULAR C RIGHT SIDE.....	1
	39 PFOZZ	5305008213869	80204	B1821BH038C175N	SCREW, CAP, HEXAGON H 0.375-16 X 1.75	3
*	40 PFOZZ	2590015314649	54786	106783-3	BRACKET, VEHICULAR C DOOR LATCH, SECONDARY (LH).....	2
*	40 PFOZZ	2590015321404	54786	106783-4	BRACKET, MOUNTING DOOR LATCH, SECONDARY (RH).....	1
*	41 PFOZZ	2590015314959	54786	106783-2	BRACKET, VEHICULAR C SECONDARY (LH).	1
	42 PFOZZ	2590015315144	54786	106783-1	BRACKET, MOUNTING DOOR LATCH, SECONDARY (RH).....	1
*	43 PFOZZ	5315015325431	54786	106782-1	LOCK PIN ASSEMBLY.....	1
	44 PFOZZ	5365015320335	54786	113325-1	SPACER, STRAIGHT.....	1
*	45 PFOZZ	5305009901347	80205	MS35190-292	SCREW, MACHINE 0.250-20 X 1.25.....	1
*	46 PFOZZ	3040015320704	54786	113339-1	CAM, DOOR.....	1
*	47 PFOZZ		1E045	500-ZN	HANDLE, BOW.....	1
*	48 PFOZZ	3040015316706	54786	113315-1	CONNECTING LINK, RIG.....	1
*	49 PFOZZ	5360015319796	54786	LE-052D-11-S	SPRING, HELICAL, EXTE 0.375 DIA. X 3.00 LONG.....	1
*	50 PFOZZ	5305009789359	96906	MS16997-49	SCREW, CAP, SOCKET HE 0.190-24 X 1.250.....	4
*	51 PFOZZ	2540015315179	54786	113335-1	HANDLE, DOOR, VEHICUL.....	1
*	52 PFOZZ	2540015328865	54786	111451-3-103	ARMOR, SUPPLEMENTAL, DOOR PANEL (RH)	1
*	53 PFOZA	5340015315649	54786	113329-3	SEAL, NONMETALLIC SP.....	1
*	54 PFOZZ	5330015319636	54786	1120A49	SEAL, NONMETALLIC 12 FT.....	V
*	55 PFOZZ	2540015329880	54786	111451-1-103	ARMOR, SUPPLEMENTAL, DOOR PANEL (LH)	1
*	56 PFOZZ	5305001193571	96906	MS35239-76	SCREW, MACHINE 0.190-24 X 1.50.....	6
*	57 PFOZZ	5330015329133	54786	113329-5	PLATE, SEAL, DOOR.....	1
*	58 PFOZZ	2540015307454	54786	113330-1	ARMOR SET, SUPPLEMEN LH.....	1
*	59 PFOZZ	2540015307453	54786	113330-2	ARMOR SET, SUPPLEMEN RH.....	1

END OF FIGURE

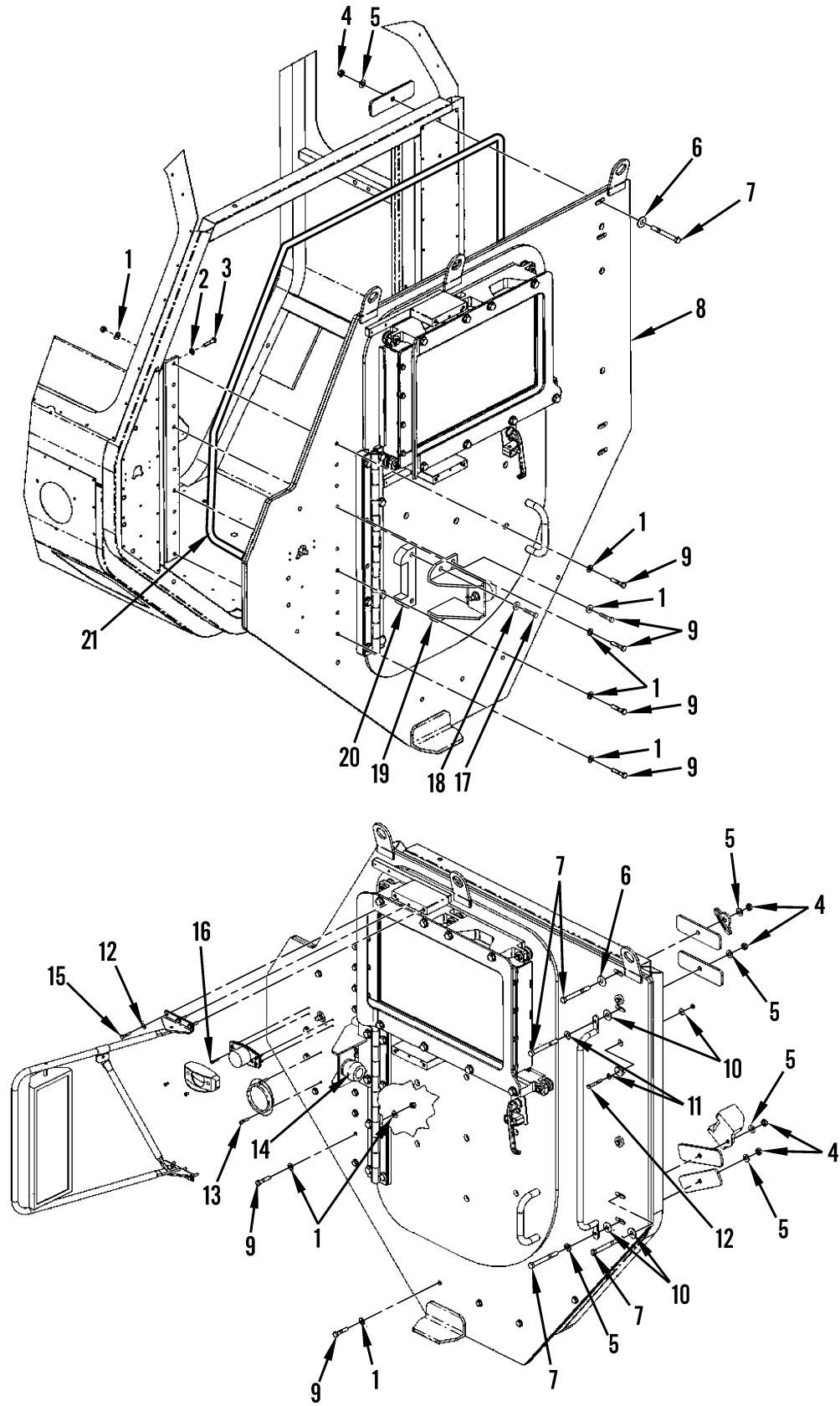

Figure 5A. Armor Door Assembly, Left and Right Side - Model B

(1) ITEM NO	(2) SMR CODE	(3) NSN	(4) CAGEC	(5) PART NUMBER	(6) DESCRIPTION AND USABLE ON CODES (UOC)	(7) QTY
GROUP 3307 SPECIAL PURPOSE KITS						
FIG. 5A ARMOR DOOR ASSEMBLY, LEFT AND RIGHT SIDES - MODEL B						
1	PAOZZ	5310000806004	96906	MS27183-14	WASHER, FLAT GR 8 (0.375" ID).....	29
2	PAOZZ	5310000814219	96906	MS27183-12	WASHER, FLAT GR 8 (0.312" ID).....	9
3	PAOZZ	5305002264831	80204	B1821BH031C150N	SCREW, CAP, HEXAGON H GR 8 (0.312-18 X 1.500").....	9
4	PAOZZ	5310002453423	80205	MS17829-7C	NUT, SELF-LOCKING, HE GR 8 (0.438-14").....	4
5	PAOZZ	5310008094061	96906	MS27183-15	WASHER, FLAT GR 8 (0.438" ID).....	5
6	PAOZZ		39428	98026A032	WASHER, FLAT GR 8, USS (0.438" ID)...	4
7	PAOZZ	5305000712063	80204	B1821BH044C400N	SCREW, CAP, HEXAGON H GR 8 (0.438-14 X 4.000").....	4
8	PAOZZ		54786	115506-1	PANEL, ARMOR LH.....	1
8	PAOZZ		54786	115506-2	PANEL, ARMOR RH.....	1
9	PAOZZ	5305011262322	80205	MS24667-56	SCREW, CAP, SOCKET HE GR 8 (0.375-16 X 1.750").....	10
10	PAOZZ		39428	98026A029	WASHER, FLAT GR 8, USS (0.250" ID)...	3
11	PAOZZ	5310008238804	96906	MS27183-9	WASHER, FLAT GR 8, SAE (0.250" ID)...	9
12	PAOZZ	5305000712511	80204	B1821BH025C200N	SCREW, CAP, HEXAGON H GR 8 (0.250-20 X 2.000").....	3
13	PAOZZ		39428	91251A440	BOLT, INTERNAL WRENC GR 8 (0.250-28 X 0.750").....	2
14	PAOZZ		54786	115563-1	BUMPER, NONMETALLIC DOOR STOP.....	1
15	PAOZZ	5305000680509	80204	B1821BH025C125N	SCREW, CAP, HEXAGON H GR 8 (0.250-20 X 1.250").....	6
16	PAOZZ		39428	92562A239	BOLT, INTERNAL WRENC GR 8 (0.190-24 X 1.000").....	4
17	PAOZZ	5305002253843	80204	B1821BH025C100N	SCREW, CAP, HEXAGON H.....	2
18	PAOZZ	5310008238804	96906	MS27183-9	WASHER, FLAT.....	2
19	PAOZZ		54786	115569-1	BRACKET, MOUNTING DOOR STOP.....	1
20	PAOZZ		54786	115571-1-103	SPACER.....	1
21	PAOZZ		54786	X-103	GASKET SIDE SEAL, 200 IN.....	1

END OF FIGURE

1	6
2-47	7-18

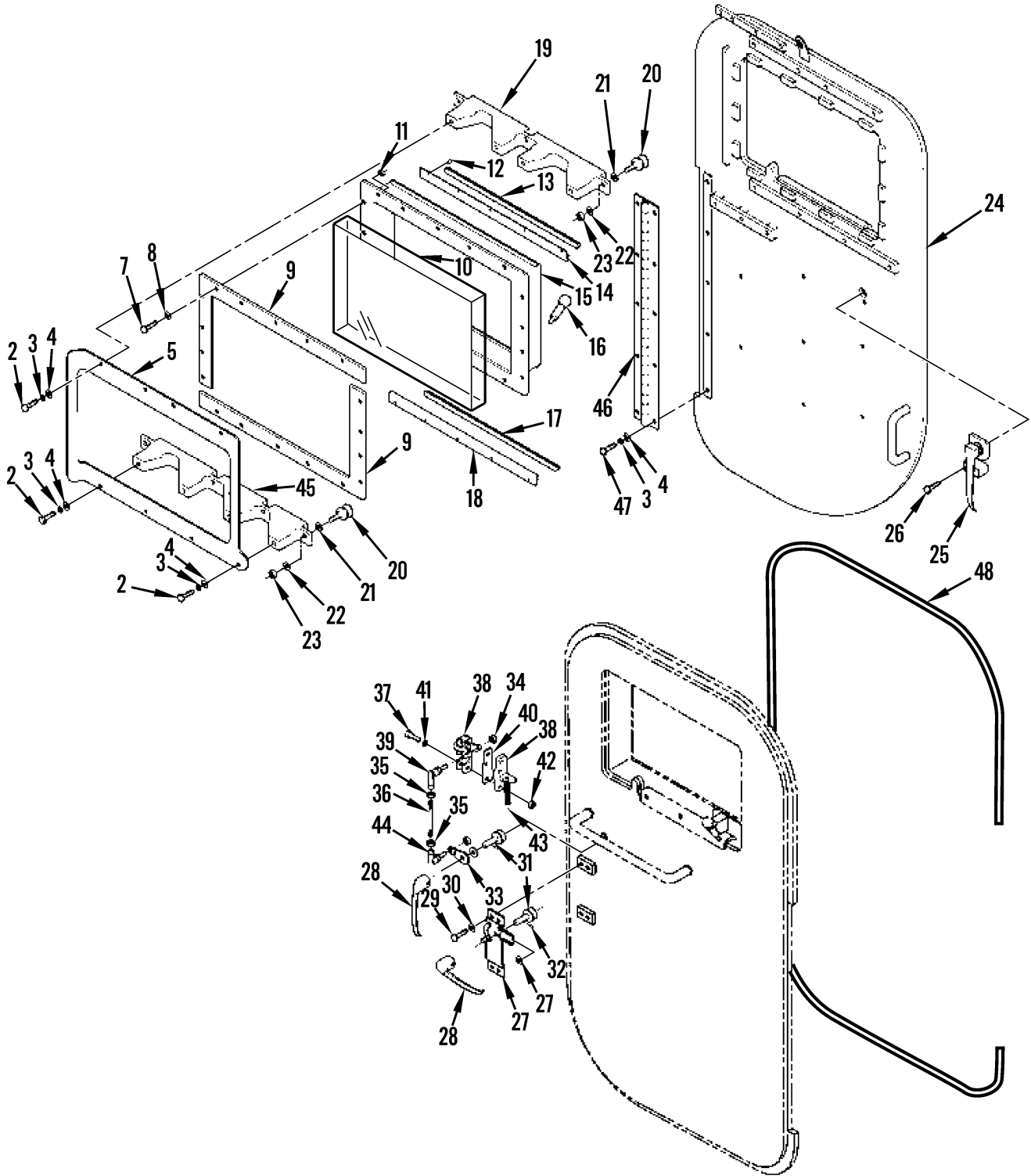

Figure 5B. Armor Door Assembly - Model B

(1) ITEM NO	(2) SMR CODE	(3) NSN	(4) CAGEC	(5) PART NUMBER	(6) DESCRIPTION AND USABLE ON CODES (UOC)	(7) QTY
GROUP 3307 SPECIAL PURPOSE KITS						
FIG. 5B ARMOR DOOR ASSEMBLY - MODEL B						
1	PAOZZ		54786	115512-1	DOOR ASSEMBLY, ARMOR LH ARMOR.....	1
1	PAOZZ		54786	115512-2	DOOR ASSEMBLY, ARMOR RH ARMOR.....	1
2	PAOZZ	5305000712082	80204	B1821BH050C475N	.SCREW, CAP, HEXAGON H.....	16
3	PAOZZ		96906	MS35338-48	.WASHER, LOCK.....	28
4	PAOZZ	5310008095998	96906	MS27183-18	.WASHER, FLAT.....	26
5	PFOZZ	2510015346917	19207	DTA182924-1	.FRAME SECTION, WINDO LH.....	1
5	PFOZZ	2510015347453	19207	DTA182924-2	.FRAME, WINDOW, VEHICU RH.....	1
6	PFOZZ	2510015344622	19207	DTA182944-1	.WINDOW, VEHICULAR LEFT SIDE.....	1
6	PFOZZ	2510015344631	19207	DTA182944-2	.WINDOW, VEHICULAR RIGHT SIDE.....	1
7	PAOZZ	5306002264826	80204	B1821BH031C088N	.BOLT, MACHINE.....	18
8	PAOZZ	5310000814219	96906	MS27183-12	.WASHER, FLAT.....	18
9	PFOZZ	2540015346972	19207	DTA182954	.ARMOR, SUPPLEMENTAL,.....	2
10	PFOZZ	2510015344638	19207	DTA182953	.WINDOW, VEHICULAR DOOR.....	1
11	PFOZZ	5310015313929	81349	M45913/2-5CG8Z	.NUT, SELF-LOCKING, HE.....	18
12	PFOZZ	5320015347031	39428	97447A025	.RIVET, BLIND.....	16
13	PFOZZ	5330015347015	19207	DTA182956-2	.SEAL, NONMETALLIC ST.....	1
14	PFOZZ	2590015346980	19207	DTA182955-2	.BRACKET, VEHICULAR C LH WINDOW WEATHERSEAL.....	2
14	PFOZZ	2590015346979	19207	DTA182955-1	.BRACKET, VEHICULAR C RH WINDOW WEATHERSEAL.....	2
15	PFOZZ	2510015408149	19207	DTA182945-1	.FRAME, WINDOW, VEHICU LEFT SIDE....	1
15	PFOZZ	2510015408129	19207	DTA182945-2	.FRAME, WINDOW, VEHICU RIGHT SIDE...	1
16	PFOZZ	5315015329119	39428	90222A419	.PIN, QUICK RELEASE.....	1
17	PFOZZ	5330015347000	19207	DTA182956-1	.SEAL, NONMETALLIC ST.....	1
18	PFOZZ	2590015346979	19207	DTA182955-1	.BRACKET, VEHICULAR C.....	2
19	PFOZZ	2590015347308	19207	DTA182854	.BRACKET, VEHICULAR C.....	1
20	PFOZZ	3040015347344	45092	VLRE-1.50-4	.CAM, CONTROL.....	14
21	PAOZZ	5365015347362	39428	94773A778	.SHIM.....	14
22	PAOZZ	5310015330278	39428	98023A032	.WASHER, FLAT.....	14
23	PAOZZ	5310015329640	39428	90636A057	.NUT, SELF-LOCKING, HE.....	14
24	PFOZZ	2510015346905	19207	DTA182838-1	DOOR, VEHICULAR LEFT SIDE.....	1
24	PFOZZ	2510015347451	19207	DTA182838-2	.DOOR, VEHICULAR RIGHT SIDE.....	1
25	PFOZZ		19220	67-5655-XPKL	.HANDLE ASSEMBLY RIGHT SIDE.....	1
25	PFOZZ		19220	67-5655-XPKR	.HANDLE ASSEMBLY RIGHT SIDE.....	1
26	PAOZZ	5305000712506	80204	B1821BH025C050N	.SCREW, CAP, HEXAGON H 0.250-20 X 0.50.....	2
27	PFOZZ	2540015347435	19220	5647-50	.LATCH, DOOR, VEHICULA COMBAT LATCH, DRIVER'S DOOR.....	2
28	PFOZZ	2540015175300	19220	53-5655X	.HANDLE, DOOR, VEHICUL.....	2
29	PAOZZ	5305000680508	80204	B1821BH025C075N	.SCREW, CAP, HEXAGON H 0.25-20 X 0.75	8
30	PAOZZ	5310005825965	80205	MS35338-44	.WASHER, LOCK 0.260 ID.....	10
31	PFOZZ	3040015347438	19207	DTA183072	.SHAFT, SHOULDERED.....	2
32	PFOZZ	5315015347440	39428	90692A700	.PIN, SPRING.....	4

(1)	(2)	(3)	(4)	(5)	(6)	(7)
ITEM	SMR			PART		
NO	CODE	NSN	CAGEC	NUMBER	DESCRIPTION AND USABLE ON CODES (UOC)	QTY
33	PFOZZ	5340015347369	19207	DTA182959	.PLATE, MOUNTING.....	2
34	PAOZZ	5310015313943	81349	M45913/2-4FG8Z	.NUT, SELF-LOCKING, HE.....	4
35	PAOZZ	5310015347396	39428	93839A805	.NUT, SELF-LOCKING, HE.....	4
36	PFOZZ	2510015347385	19207	DTA182960	.ROD, DOOR CHECK, VEHI.....	2
37	PAOZZ	5306002264832	80204	B1821BH031C175N	.BOLT, MACHINE.....	6
38	PFOZZ	2540011516209	19220	400-L	.CYLINDER, LOCK, VEHIC LH.....	1
38	PFOZZ	2540011515475	19220	400-R	.CYLINDER, LOCK, VEHIC RH.....	1
39	PFOZZ	3040015347399	6K430	EST250	.BALL JOINT.....	2
40	PFOZZ	5365015347367	19207	DTA182958	.SHIM.....	12
41	PAOZZ	5310000814219	96906	MS27183-12	.WASHER, FLAT 5/16.....	6
42	PAOZZ		81349	M45193/2-5CG8Z	.NUT, SELF-LOCKING.....	6
43	PAOZZ	5360012829316	19220	2-300-P5	.SPRING, HELICAL, EXTE.....	2
44	PFOZZ	3040015347401	6K430	ES250	.BALL JOINT ROD END.....	1
45	PFOZZ	2590015347310	19207	DTA182855-1	.BRACKET, VEHICULAR C LH.....	1
45	PFOZZ	2590015346980	19207	DTA182955-2	.BRACKET, VEHICULAR C RH.....	2
46	PFOZZ	2510015347342	39428	15665A637	.HINGE, DOOR, VEHICULA.....	2
47	PAOZZ	5305007320511	80204	B1821BH050C113N	.SCREW, CAP, HEXAGON H.....	10
48	PAOZZ		54786	437583X3/8A	GASKET, NONMETALLIC.....	1

END OF FIGURE

1
2-29

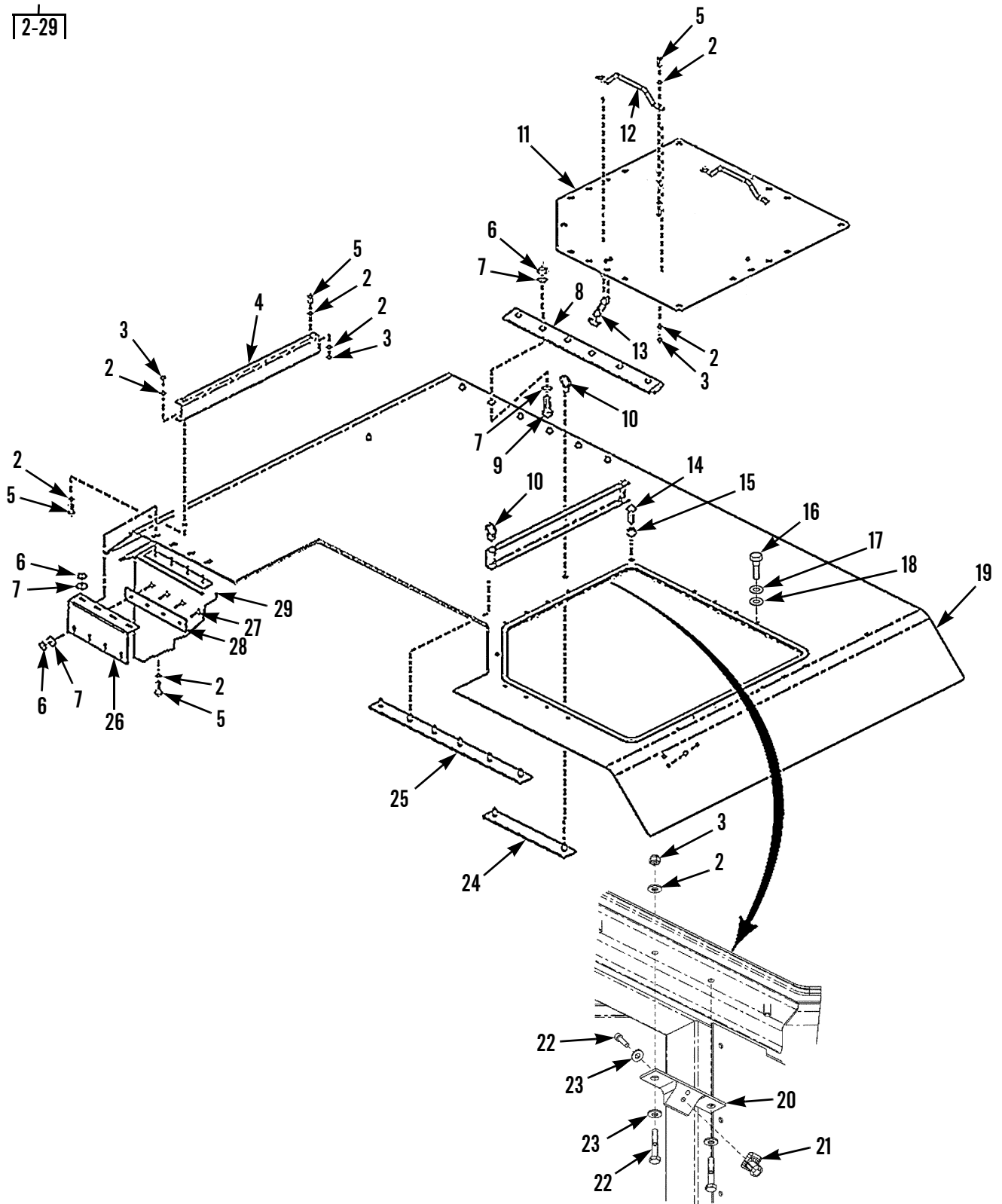

Figure 6. Roof Armor Protection Kit

(1) ITEM NO	(2) SMR CODE	(3) NSN	(4) CAGEC	(5) PART NUMBER	(6) DESCRIPTION AND USABLE ON CODES (UOC)	(7) QTY
GROUP 3307 SPECIAL PURPOSE KITS						
FIG. 6 ROOF ARMOR PROTECTION KIT						
1	PAOZZ	2540015265312	54786	106704-3	ARMOR SET,SUPPLEMEN ROOF.....	1
2	PFOZZ	5310005825965	80063	104-1S12M	.WASHER,FLAT 0.250 ID PART OF KIT P/N 111444-1.....	21
*	3	PFOZZ	5310000614650	45152 114356A	.NUT,SELF-LOCKING,HE 0.250-20 PART OF KIT P/N 111444-1.....	8
*	4	PFOZZ	9520015324130	54786 113347-1	.CHANNEL,ARMOR.....	2
5	PFOZZ	5305002253843	80204	B1821BH025C100N	.SCREW,CAP,HEXAGON H 0.250-20 X 1.00 PART OF KIT P/N 111444-1.....	13
6	PFOZZ	5310009359021	96906	MS51943-35	.NUT,SELF-LOCKING,HE 0.375-16 PART OF KIT P/N 111444-1.....	15
7	PFOZZ	5310000806004	96906	MS27183-14	.WASHER,FLAT 0.375 ID PART OF KIT P/N 111444-1.....	19
8	PFOZZ	2540015319644	54786	106735-1-103	.ARMOR PLATE ROOF PANEL FRONT BRACKET.....	1
*	9	PFOZZ	5305012705365	39428 90086A545	.SCREW,TAPPING 0.25-20 X 1.250 PART OF KIT P/N 111444-1.....	5
10	PFOZZ	5310015314881	54786	106795-1	.NUT,EYE PART OF KIT P/N 111444-1...	2
*	11	PFOZZ	2540015328874	54786 113346-1	.ARMOR,SUPPLEMENTAL, ESCAPE HATCH..	1
*	12	PFOZZ	5340015326723	27182 S31-8XXBPS2H	.HANDLE,BOW.....	2
13	PFOZZ	5340014684593	94222	F7-51	.CATCH,CLAMPING.....	4
14	PFOZZ		54786	TBD-012	.SCREW,SELF-DRILLING 0.312-18 X 1.75.....	6
*	15	PFOZZ	5365015330220	51506 8080R S.53 5	.SPACER,RING.....	2
16	PFOZZ	5306002264829	80204	B1821BH031C125N	.BOLT,MACHINE 0.312-18 X 1.25 PART OF KIT P/N 111444-1.....	14
17	PFOZZ	5310000814219	96906	MS27183-12	.WASHER,FLAT 0.312 ID PART OF KIT P/N 111444-1.....	20
18	PFOZZ	5310004079566	80205	MS35338-45	.WASHER,LOCK 0.312 ID.....	12
*	19	PFOZZ	2540015330491	54786 106781-3	.ARMOR,SUPPLEMENTAL, ROOF ARMOR PANEL.....	1
20	PFOZZ	2590015316883	54786	113357-1	.BRACKET,VEHICULAR C.....	4
*	21	PFOZZ	5360015330285	39428 3126A84	.SPRING,HELICAL,TORS 0.190-32.....	4
*	22	PFOZZ	5305005794576	96906 MS35265-65	.SCREW,MACHINE 0.190-24 X 0.750....	12
*	23	PFOZZ	5310001884185	19207 7402857	.WASHER,FLAT 0.190 ID.....	12
*	24	PFOZZ	2540015315214	54786 106780-3-103	.ARMOR,SUPPLEMENTAL, ROOF ARMOR STUD PLATE.....	1
*	25	PFOZZ	2590015317281	54786 106780-1-103	.ARMOR,SUPPLEMENTAL, ROOF ARMOR STUD PLATE.....	1
*	26	PFOZZ	2590015325767	54786 106736-1	.ARMOR,SUPPLEMENTAL, ROOF PANEL REAR BRACKET.....	1
27	PFOZZ	5305007252317	80204	B1821BH038C150N	.SCREW,CAP,HEXAGON H 0.375-16 X 1.50.....	4
*	28	PFOZZ	5365015322255	54786 106796-1	.SPACER,STRAIGHT ROOF BRACKET SHIM.	1

(1)	(2)	(3)	(4)	(5)	(6)	(7)	
ITEM	SMR			PART			
NO	CODE	NSN	CAGEC	NUMBER	DESCRIPTION AND USABLE ON CODES (UOC)	QTY	
*	29	PFOZZ	2540015330490	54786	106780-2	.ARMOR,SUPPLEMENTAL, ROOF ARMOR STUD PLATE.....	1

END OF FIGURE

1
2-28

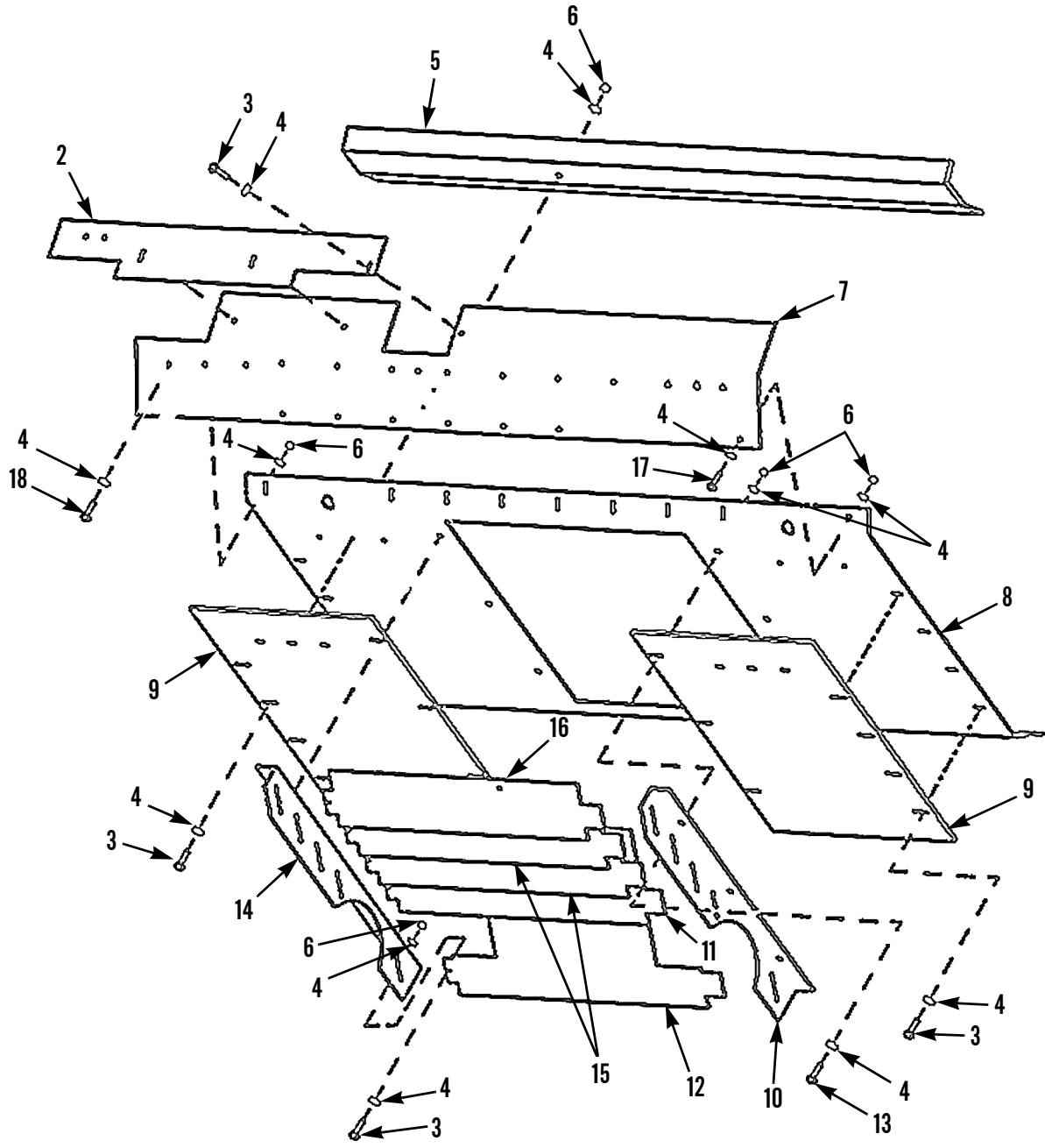

Figure 7. Front Armor Protection Kit (Sheet 1 of 2)

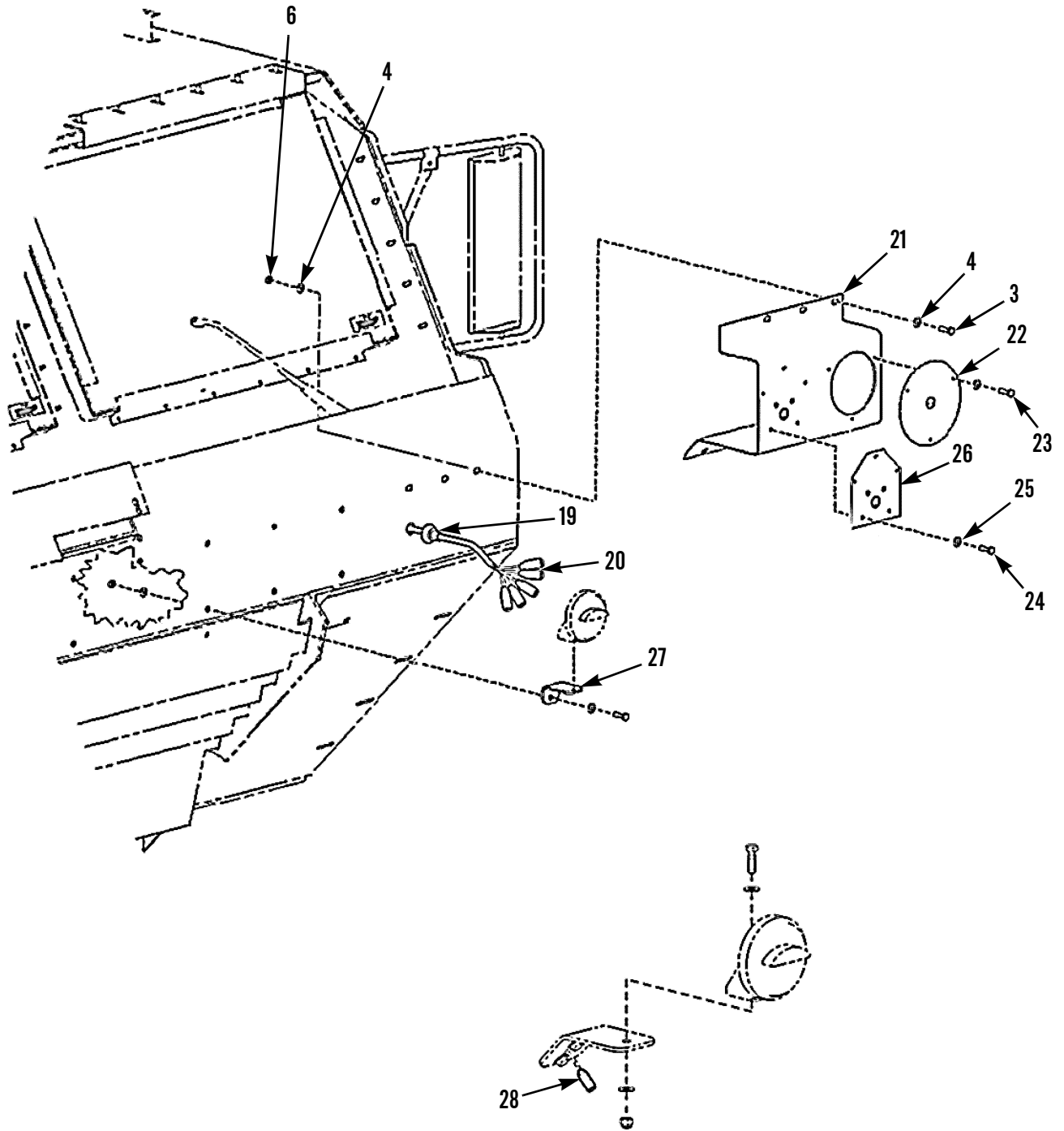

Figure 7. Front Armor Protection Kit (Sheet 2 of 2)

(1) ITEM NO	(2) SMR CODE	(3) NSN	(4) CAGEC	(5) PART NUMBER	(6) DESCRIPTION AND USABLE ON CODES (UOC)	(7) QTY
GROUP 3307 SPECIAL PURPOSE KITS						
FIG. 7 FRONT ARMOR PROTECTION KIT						
*	1	PAOZZ 2540015265320	54786	106705-3	ARMOR SET,SUPPLEMEN FRONT ARMOR PROTECTION.....	1
*	2	PFOZZ 2540015328080	54786	111437-1	.ARMOR,SUPPLEMENTAL, UPPER BRUSH GUARD.....	1
	3	PFOZZ 5305007252317	80204	B1821BH038C150N	.SCREW,CAP,HEXAGON H 0.375-16 X 1.50.....	29
*	4	PFOZZ 5310000806004	96906	MS27183-14	.WASHER,FLAT 0.375 ID PART OF KIT P/N 111444-1.....	79
*	5	PFOZZ 2540015329891	54786	106759-1	.ARMOR,SUPPLEMENTAL, UPPER BRUSH GUARD SHIM.....	1
*	6	PFOZZ 5310009359021	96906	MS51943-35	.NUT,SELF-LOCKING,HE 0.375-16 PART OF KIT P/N 111444-1.....	31
*	7	PFOZZ 2540015328870	54786	111407-1	.ARMOR,SUPPLEMENTAL, UPPER BRUSH GUARD.....	1
	8	PFOZZ 2540015328109	54786	111496-1	.ARMOR,SUPPLEMENTAL, LOWER BRUSH GUARD.....	1
*	9	PFOZZ 2540015328073	54786	111426-1	.ARMOR,SUPPLEMENTAL, BRUSH GUARD...	2
*	10	PFOZZ 2540015327378	54786	106772-1	.ARMOR,SUPPLEMENTAL, DRIVER'S SIDE LOUVERED GRILL BRACKET.....	1
*	11	PFOZZ 2540015330546	54786	111457-3-103	.ARMOR,SUPPLEMENTAL, LOUVERED GRILL PANEL (NEXT TO BOTTOM).....	1
*	12	PFOZZ 2540015330637	54786	111457-4-103	.ARMOR,SUPPLEMENTAL, LOUVERED GRILL PANEL (BOTTOM).....	1
	13	PFOZZ 5305000680511	80204	B1821BH038C125N	.SCREW,CAP,HEXAGON H 0.375-16 X 1.25.....	9
*	14	PFOZZ 2540015322578	54786	106772-2	.ARMOR,SUPPLEMENTAL, PASSENGER LOUVERED GRILL BRACKET.....	1
*	15	PFOZZ 2540015330496	54786	111457-2	.ARMOR,SUPPLEMENTAL, LOUVERED GRILL, MIDDLE.....	2
*	16	PFOZZ 2540015328873	54786	111457-1	.ARMOR,SUPPLEMENTAL, LOUVERED GRILL, TOP.....	1
	17	PFOZZ 5305008213869	80204	B1821BH038C175N	.SCREW,CAP,HEXAGON H 0.375-16 X 1.75.....	6
*	18	PFOZZ 5305008576886	80204	B1821BH038C450N	.SCREW,CAP,HEXAGON H 0.375-16 X 4.50 PART OF KIT P/N 111444-1.....	2
*	19	PFOZZ 5325015322185	54786	111453-1	.GROMMET,NONMETALLIC.....	6
*	20	PFOZZ 6150015326616	54786	111438-4	.HARNESSE,ELECTRICAL 7-WIRE PIGTAIL.	2
*	21	PFOZZ 2590015321826	54786	111418-1	.BRACKET,VEHICULAR C HEADLIGHT.....	1
*	21	PFOZZ 2590015327371	54786	111418-2	.BRACKET,VEHICULAR C HEADLIGHT.....	1
*	22	PFOZZ 5340015330295	54786	113379-1	.COVER,ACCESS HEADLIGHT.....	2
	23	XDOZZ	25795	11SMPPCAK-025005 0	.SCREW,SELF-DRILLING #14-0.500.....	6
	24	PFOZZ 5305002253843	80204	B1821BH025C100N	.SCREW,CAP,HEXAGON H 1/4-20 X 1.00 PART OF KIT P/N 111444-1.....	10

(1) ITEM NO	(2) SMR CODE	(3) NSN	(4) CAGEC	(5) PART NUMBER	(6) DESCRIPTION AND USABLE ON CODES (UOC)	(7) QTY
25	PFOZZ	5310005825965	80205	MS35338-44	.WASHER, LOCK 1/4 ID PART OF KIT P/N 111444-1.....	20
* 26	PFOZZ	2590015325773	54786	111442-1	.BRACKET, MOUNTING MARKER LIGHT ADAPTER.....	2
* 27	PFOZZ	2590015330494	54786	111459-1	.ARMOR, SUPPLEMENTAL, BLACKOUT LIGHT BRACKET.....	1
* 28	PFOZZ	6150015326696	54786	111438-3	.PIGTAIL WIRE 1-WIRE.....	3

END OF FIGURE

(1) ITEM NO	(2) SMR CODE	(3) NSN	(4) CAGEC	(5) PART NUMBER	(6) DESCRIPTION AND USABLE ON CODES (UOC)	(7) QTY
GROUP 94 REPAIR KITS						
GROUP 9401 REPAIR KITS						
FIG. KITS						
*	PAOZZ	2540015265298	54786	106707-1	TEMPLATE KIT, BRUSH.....	1
					ARMOR, SUPPLEMENTAL, (V)	1-19
					GUIDE, DRILL (V)	2-2
					TEMPLATE, ARMOR ()	2-1
*	PAOZZ	5325015265340	54786	111444-1	FASTENER KIT, EXTRA.....	1
					BOLT, MACHINE (2)	5-21
					BOLT, MACHINE (2)	4-27
					BOLT, MACHINE (14)	6-16
					FASTENER KIT, EXTRA (1)	3-15
					INSERT, SCREW THREAD (4)	4-16
					NUT, EYE (2)	6-10
					NUT, PLAIN, BLIND RIV (3)	4-34
					NUT, SELF-LOCKING, HE (31)	7-6
					NUT, SELF-LOCKING, HE (2)	4-26
					NUT, SELF-LOCKING, HE (25)	4-23
					NUT, SELF-LOCKING, HE (13)	3-8
					NUT, SELF-LOCKING, HE (15)	6-6
					NUT, SELF-LOCKING, HE (8)	6-3
					NUT, SELF-LOCKING, HE (14)	3-20
					NUT, SELF-LOCKING, HE (96)	2-7
					NUT, SELF-LOCKING, HE (2)	2-21
					NUT, SELF-LOCKING, HE (20)	1-12
					SCREW, CAP, HEXAGON H (5)	3-10
					SCREW, CAP, HEXAGON H (2)	7-18
					SCREW, CAP, HEXAGON H (10)	7-24
					SCREW, CAP, HEXAGON H (10)	4-11
					SCREW, CAP, HEXAGON H (6)	5-25
					SCREW, CAP, HEXAGON H (3)	5-28
					SCREW, CAP, SOCKET HE (1)	5-45
					SCREW, CAP, SOCKET HE (10)	4-9
					SCREW, CAP, HEXAGON H (13)	6-5
					SCREW, CAP, HEXAGON H (32)	2-9
					SCREW, CAP, HEXAGON H (4)	1-17
					SCREW, MACHINE (4)	5-1
					SCREW, TAPPING (5)	6-9
					WASHER, FLAT (79)	7-4
					WASHER, FLAT (22)	4-10
					WASHER, FLAT (44)	4-17
					WASHER, FLAT (9)	4-3
					WASHER, FLAT (13)	3-7
					WASHER, FLAT (20)	6-17
					WASHER, FLAT (19)	6-7

(1) ITEM NO	(2) SMR CODE	(3) NSN	(4) CAGEC	(5) PART NUMBER	(6) DESCRIPTION AND USABLE ON	(7) CODES (UOC) QTY
					WASHER, FLAT	(21) 6-2
					WASHER, FLAT	(14) 3-3
					WASHER, FLAT	(14) 3-21
					WASHER, FLAT	(133) 2-8
					WASHER, FLAT	(2) 2-20
					WASHER, FLAT	(8) 1-8
					WASHER, FLAT	(38) 1-4
					WASHER, LOCK	(20) 7-25
					WASHER, LOCK	(10) 4-20

END OF FIGURE

CROSS-REFERENCE INDEXES

NATIONAL STOCK NUMBER INDEX

STOCK NUMBER	FIG.	ITEM	STOCK NUMBER	FIG.	ITEM
5310-00-009-7682	4	10	5305-00-225-3843	6	5
5305-00-012-0620	5	31		7	24
5310-00-014-5847	5	10		5A	17
5305-00-022-7242	5	1	5306-00-226-4825	4	27
5305-00-034-1212	4	33	5306-00-226-4826	5B	7
5310-00-044-3339	5	9	5306-00-226-4827	5	20
5310-00-061-4650	2	7	5306-00-226-4829	5	21
	3	8		6	16
	3	12	5305-00-226-4831	4	11
	3	20		5A	3
	4	26	5306-00-226-4832	5B	37
	6	3	5310-00-241-6659	4	8
5305-00-068-0508	2	22	5310-00-245-3423	5A	4
	3	2	5310-00-285-8124	2	8
	3	18	5310-00-407-9566	6	18
	5B	29	5310-00-409-3333	1	12
5305-00-068-0509	3	6	5306-00-554-4767	5	27
	5	34	5305-00-579-4576	6	22
	5A	15	5310-00-582-5965	7	25
5305-00-068-0511	7	13		5B	30
5305-00-071-2063	5A	7	5310-00-685-8308	3	3
5305-00-071-2069	1	9		3	11
5305-00-071-2082	5B	2		4	20
5305-00-071-2083	5	23		5	11
5305-00-071-2506	4	21		6	2
	5B	26	5305-00-725-2317	4	31
5305-00-071-2509	3	14		6	27
	5	14		7	3
5305-00-071-2510	2	16	5305-00-732-0511	5B	47
5305-00-071-2511	5A	12	5305-00-781-3930	5	28
5305-00-071-2522	5	25	5305-00-782-9489	4	18
5310-00-080-6004	2	20	5310-00-809-4061	5A	5
	3	7	5310-00-809-5997	1	8
	3	21	5310-00-809-5998	5B	4
	4	17	5310-00-809-8533	1	4
	6	7	5305-00-821-3869	5	39
	7	4		7	17
	5A	1	5310-00-823-8804	5A	11
5310-00-081-4219	6	17		5A	18
	5A	2	5305-00-846-5703	4	29
	5B	8	5305-00-857-6886	7	18
	5B	41	5305-00-922-7994	1	16
5305-00-119-3571	5	56	5310-00-934-9760	4	25
5310-00-177-0973	4	3	5310-00-935-9021	2	21
5310-00-180-0277	2	3		4	23
5310-00-183-4421	5	5		6	6
5310-00-188-4185	6	23		7	6
			5305-00-938-1539	1	3
5305-00-225-3843	2	9	5305-00-947-4360	1	17
	3	10	5305-00-964-0503	5	29

CROSS-REFERENCE INDEXES

NATIONAL STOCK NUMBER INDEX

STOCK NUMBER	FIG.	ITEM	STOCK NUMBER	FIG.	ITEM
5305-00-978-9359	5	50	2510-01-531-5993	5	17
5305-00-990-1347	5	45	3040-01-531-6706	5	48
5310-01-101-3374	5	4	2590-01-531-6883	6	20
5310-01-110-9790	5	6	2590-01-531-7198	5	17
5310-01-112-4390	5	8		5	32
5305-01-126-2322	4	9	2590-01-531-7232	4	12
	5A	9	2510-01-531-7235	2	14
2540-01-151-5475	5B	38	2590-01-531-7281	6	25
2540-01-151-6209	5B	38	2590-01-531-7282	2	5
5310-01-232-7702	5A	10	3465-01-531-9566	2	2
5305-01-270-5365	6	9	5330-01-531-9636	5	54
5360-01-282-9316	5B	43	5330-01-531-9639	5	12
5310-01-413-3276	4	34	2540-01-531-9644	6	8
5310-01-415-1314	5	7	5360-01-531-9796	5	49
5340-01-468-4593	6	13	2590-01-532-0241	5	38
5325-01-483-7480	4	16	2590-01-532-0269	2	6
2540-01-511-9859	5	36	5365-01-532-0335	5	44
5340-01-512-7409	5	37	2590-01-532-0577	2	15
2540-01-517-5300	5B	28	3040-01-532-0704	5	46
2540-01-525-1202	4	1	2590-01-532-1054	5	33
2540-01-525-1203	4	1	2590-01-532-1404	5	40
2540-01-525-1204	2	4	2590-01-532-1423	2	23
2540-01-526-5296	1	1	2590-01-532-1826	7	21
2540-01-526-5298	KITS		2540-01-532-1831	1	15
2540-01-526-5300	3	13	5306-01-532-1851	2	19
2540-01-526-5303	3	1	5365-01-532-2111	5	15
2540-01-526-5312	6	1	5325-01-532-2185	4	24
2540-01-526-5320	7	1		7	19
5325-01-526-5340	3	15	5365-01-532-2251	5	13
	KITS		5365-01-532-2255	6	28
2540-01-530-7355	2	12	5310-01-532-2541	3	5
2540-01-530-7453	5	58		3	17
2540-01-530-7454	5	58	2540-01-532-2578	7	14
5310-01-531-3929	5B	11	9520-01-532-4130	6	4
5310-01-531-3943	5B	34	3120-01-532-5228	4	30
2540-01-531-4364	5B	25	5340-01-532-5381	4	28
2540-01-531-4369	5B	25	5315-01-532-5431	5	43
2590-01-531-4649	5	40	2590-01-532-5767	6	26
5310-01-531-4881	6	10	2590-01-532-5773	7	26
2590-01-531-4959	5	41	3040-01-532-6610	2	11
2590-01-531-4966	5	32	6150-01-532-6616	7	20
2540-01-531-5026	5	16	6150-01-532-6696	7	28
5340-01-531-5029	4	32	5340-01-532-6723	5	22
2590-01-531-5106	2	13		6	12
2590-01-531-5144	5	42	2540-01-532-7364	1	7
2590-01-531-5145	5	26	2590-01-532-7371	7	21
2590-01-531-5146	5	18	2540-01-532-7378	7	10
2540-01-531-5179	5	51	2510-01-532-7384	4	19
2540-01-531-5214	6	24	2540-01-532-7768	5	35
5340-01-531-5649	5	53	2540-01-532-8073	7	9

CROSS-REFERENCE INDEXES

NATIONAL STOCK NUMBER INDEX

STOCK NUMBER	FIG.	ITEM	STOCK NUMBER	FIG.	ITEM
2540-01-532-8080	7	2	2540-01-533-9242	2	15
2540-01-532-8088	3	9	2510-01-534-4622	5B	6
2540-01-532-8101	4	14	2510-01-534-4631	5B	6
2540-01-532-8103	4	6	2510-01-534-4638	5B	10
2540-01-532-8109	7	8	2510-01-534-6905	5B	24
2540-01-532-8865	5	52	2510-01-534-6917	5B	5
2540-01-532-8866	2	23	2540-01-534-6972	5B	9
2540-01-532-8868	4	15	2590-01-534-6979	5B	14
2540-01-532-8870	7	7		5B	18
2540-01-532-8873	7	16	2590-01-534-6980	5B	14
2540-01-532-8874	6	11		5B	45
2540-01-532-8901	4	7	5330-01-534-7000	5B	17
2540-01-532-8904	1	5	5330-01-534-7015	5B	13
2540-01-532-8905	1	13	5320-01-534-7031	5B	12
5315-01-532-9119	5B	16	2590-01-534-7308	5B	19
5305-01-532-9127	2	10	2590-01-534-7310	5B	45
5330-01-532-9133	5	57	2510-01-534-7342	5B	46
5340-01-532-9226	5	24	3040-01-534-7344	5B	20
5310-01-532-9640	5B	23	5365-01-534-7362	5B	21
2540-01-532-9880	5	55	5365-01-534-7367	5B	40
2540-01-532-9883	4	4	5340-01-534-7369	5B	33
2540-01-532-9885	3	16	2510-01-534-7385	5B	36
2540-01-532-9888	1	6	5310-01-534-7396	5B	35
2540-01-532-9891	7	5	3040-01-534-7399	5B	39
2590-01-533-0188	5	3	3040-01-534-7401	5B	44
5365-01-533-0220	6	15	2540-01-534-7435	5B	27
5365-01-533-0222	4	13	3040-01-534-7438	5B	31
5310-01-533-0278	5B	22	5315-01-534-7440	5B	32
5360-01-533-0285	6	21	2510-01-534-7451	5B	24
5340-01-533-0295	7	22	2510-01-534-7453	5B	5
2540-01-533-0490	6	29	2510-01-540-8129	5B	15
2540-01-533-0491	6	19	2510-01-540-8149	5B	15
2540-01-533-0492	4	6			
2540-01-533-0493	1	18			
2590-01-533-0494	7	27			
2540-01-533-0496	7	15			
2540-01-533-0497	4	5			
2540-01-533-0505	1	11			
2540-01-533-0508	1	19			
5365-01-533-0520	1	14			
5365-01-533-0525	5	2			
2540-01-533-0546	7	11			
2540-01-533-0547	2	18			
2540-01-533-0549	1	2			
2590-01-533-0551	2	17			
2540-01-533-0637	7	12			
2540-01-533-0865	1	10			
2540-01-533-0868	2	1			
5365-01-533-0924	5	30			
2540-01-533-9230	2	13			

CROSS-REFERENCE INDEXES

CAGEC	PART NUMBER	PART NUMBER INDEX		FIG.	ITEM
			STOCK NUMBER		
78276	ALS4-518-150		5310-01-413-3276	4	34
78276	ALS4-616-150		5325-01-483-7480	4	16
80204	B1821BH025C050N		5305-00-071-2506	4	21
				5B	26
80204	B1821BH025C075N		5305-00-068-0508	2	22
				3	2
				3	18
				5B	29
80204	B1821BH025C100N		5305-00-225-3843	2	9
				3	10
				6	5
				7	24
				5A	17
80204	B1821BH025C125N		5305-00-068-0509	3	6
				5	34
				5A	15
80204	B1821BH025C150N		5305-00-071-2509	3	14
				5	14
80204	B1821BH025C175N		5305-00-071-2510	2	16
80204	B1821BH025C200N		5305-00-071-2511	5A	12
80204	B1821BH025C475N		5305-00-071-2522	5	25
80204	B1821BH031C075N		5306-00-226-4825	4	27
80204	B1821BH031C088N		5306-00-226-4826	5B	7
80204	B1821BH031C100N		5306-00-226-4827	5	20
80204	B1821BH031C125N		5306-00-226-4829	5	21
				6	16
80204	B1821BH031C150N		5305-00-226-4831	4	11
				5A	3
80204	B1821BH031C175N		5306-00-226-4832	5B	37
80204	B1821BH038C125N		5305-00-068-0511	7	13
80204	B1821BH038C150N		5305-00-725-2317	4	31
				6	27
				7	3
80204	B1821BH038C175N		5305-00-821-3869	5	39
				7	17
80204	B1821BH038C200N		5305-00-782-9489	4	18
80204	B1821BH038C300N		5305-00-846-5703	4	29
80204	B1821BH038C450N		5305-00-857-6886	7	18
80204	B1821BH038C475N		5305-00-781-3930	5	28
80204	B1821BH038C500N		5305-00-964-0503	5	29
80204	B1821BH044C400N		5305-00-071-2063	5A	7
80204	B1821BH050C113N		5305-00-732-0511	5B	47
80204	B1821BH050C150N		5305-00-071-2069	1	9
80204	B1821BH050C475N		5305-00-071-2082	5B	2
80204	B1821BH050C500N		5305-00-071-2083	5	23
80204	B1821BH075C200N		5305-00-938-1539	1	3
80204	B1821BH075C250N		5305-00-922-7994	1	16
80204	B1821BH075C450N		5305-00-947-4360	1	17
19220	D-400-53		5340-01-512-7409	5	37
19207	DTA182838-1		2510-01-534-6905	5B	24
19207	DTA182838-2		2510-01-534-7451	5B	24

CROSS-REFERENCE INDEXES

CAGEC	PART NUMBER	PART NUMBER INDEX		FIG.	ITEM
			STOCK NUMBER		
19207	DTA182854		2590-01-534-7308	5B	19
19207	DTA182855-1		2590-01-534-7310	5B	45
19207	DTA182924-1		2510-01-534-6917	5B	5
19207	DTA182924-2		2510-01-534-7453	5B	5
19207	DTA182944-1		2510-01-534-4622	5B	6
19207	DTA182944-2		2510-01-534-4631	5B	6
19207	DTA182945-1		2510-01-540-8149	5B	15
19207	DTA182945-2		2510-01-540-8129	5B	15
19207	DTA182953		2510-01-534-4638	5B	10
19207	DTA182954		2540-01-534-6972	5B	9
19207	DTA182955-1		2590-01-534-6979	5B	14
				5B	18
19207	DTA182955-2		2590-01-534-6980	5B	14
				5B	45
19207	DTA182956-1		5330-01-534-7000	5B	17
19207	DTA182956-2		5330-01-534-7015	5B	13
19207	DTA182958		5365-01-534-7367	5B	40
19207	DTA182959		5340-01-534-7369	5B	33
19207	DTA182960		2510-01-534-7385	5B	36
19207	DTA183072		3040-01-534-7438	5B	31
19220	D400-53			5	37
6K430	EST250		3040-01-534-7399	5B	39
6K430	ES250		3040-01-534-7401	5B	44
94222	F7-51		5340-01-468-4593	6	13
54786	LE-052D-11-S		5360-01-531-9796	5	49
96906	MS16997-49		5305-00-978-9359	5	50
80205	MS17829-7C		5310-00-245-3423	5A	4
80205	MS17829Z3C		5310-01-415-1314	5	7
80205	MS24667-56		5305-01-126-2322	4	9
				5A	9
96906	MS27183-12		5310-00-081-4219	6	17
				5A	2
				5B	8
				5B	41
96906	MS27183-14		5310-00-080-6004	2	20
				3	7
				3	21
				4	17
				6	7
				7	4
				5A	1
96906	MS27183-15		5310-00-809-4061	5A	5
96906	MS27183-17		5310-00-809-5997	1	8
96906	MS27183-18		5310-00-809-5998	5B	4
96906	MS27183-23		5310-00-809-8533	1	4
96906	MS27183-50		5310-00-285-8124	2	8
96906	MS27183-9		5310-00-823-8804	5A	11
				5A	18
80205	MS35190-292		5305-00-990-1347	5	45
96906	MS35239-76		5305-00-119-3571	5	56

CROSS-REFERENCE INDEXES

CAGEC	PART NUMBER	PART NUMBER INDEX		FIG.	ITEM
			STOCK NUMBER		
96906	MS35241-72		5305-00-012-0620	5	31
96906	MS35249-75		5305-00-022-7242	5	1
96906	MS35265-65		5305-00-579-4576	6	22
80205	MS35333-76		5310-00-180-0277	2	3
80205	MS35338-44		5310-00-582-5965	7	25
				5B	30
80205	MS35338-45		5310-00-407-9566	6	18
96906	MS35338-48			5B	3
80205	MS35457-28			4	22
80205	MS35649-204		5310-00-934-9760	4	25
96906	MS51943-35		5310-00-935-9021	2	21
				4	23
				6	6
				7	6
96906	MS51943-45		5310-00-409-3333	1	12
81349	M45193/2-5CG8Z			5B	42
81349	M45913/2-4FG8Z		5310-01-531-3943	5B	34
81349	M45913/2-5CG8Z		5310-01-531-3929	5B	11
81349	M45913/3-7CG8C		5310-00-241-6659	4	8
80063	SM-C-617837-2		5310-01-101-3374	5	4
80063	SM-D-450462-4		5310-00-014-5847	5	10
27182	S31-8XXBPS2H		5340-01-532-6723	6	12
54786	TBD-012			6	14
45092	VLRE-1.50-4		3040-01-534-7344	5B	20
82458	WLA3816GRB		5310-00-183-4421	5	5
54786	X-103			5A	21
54786	103255CFP-019003		5305-01-532-9127	2	10
	1				
80063	104-1S12M		5310-00-685-8308	3	3
				3	11
				4	20
				5	11
				6	2
54786	106701-4		2540-01-525-1204	2	4
54786	106702-3		2540-01-526-5300	3	13
54786	106702-4		2540-01-526-5303	3	1
54786	106703-10		2540-01-525-1202	4	1
54786	106703-9		2540-01-525-1203	4	1
54786	106704-3		2540-01-526-5312	6	1
54786	106705-3		2540-01-526-5320	7	1
54786	106706-3		2540-01-526-5296	1	1
54786	106707-1		2540-01-526-5298		
				KITS	
54786	106715-1		2540-01-532-1831	1	15
54786	106717-1		2540-01-532-7364	1	7
54786	106717-2-103		2540-01-533-0549	1	2
54786	106719-1		2540-01-533-0493	1	18
54786	106721-1-103		2510-01-531-7235	2	14
54786	106724-3		2540-01-532-9885	3	16
54786	106724-4		2540-01-532-8088	3	9
54786	106729-3		2540-01-533-0497	4	5
54786	106729-5		2540-01-532-9883	4	4

CROSS-REFERENCE INDEXES

CAGEC	PART NUMBER	PART NUMBER INDEX		FIG.	ITEM
			STOCK NUMBER		
54786	106733-1-103		2540-01-533-0547	2	18
54786	106734-1-103		2540-01-533-9230	2	13
54786	106734-2-103		2540-01-533-9242	2	15
54786	106734-3-103		2540-01-532-8866	2	23
54786	106734-4			3	4
				3	19
54786	106734-5-103		2590-01-531-5106	2	13
54786	106734-6-103		2590-01-532-0577	2	15
54786	106734-7-103		2590-01-532-1423	2	23
54786	106735-1-103		2540-01-531-9644	6	8
54786	106736-1		2590-01-532-5767	6	26
54786	106746-1-103		2590-01-533-0551	2	17
54786	106753-1		2540-01-532-8905	1	13
54786	106754-1		2540-01-532-8904	1	5
54786	106759-1		2540-01-532-9891	7	5
54786	106772-1		2540-01-532-7378	7	10
54786	106772-2		2540-01-532-2578	7	14
54786	106777-1		5365-01-533-0520	1	14
54786	106778-1		2540-01-532-9888	1	6
54786	106780-1-103		2590-01-531-7281	6	25
54786	106780-2		2540-01-533-0490	6	29
54786	106780-3-103		2540-01-531-5214	6	24
54786	106781-3		2540-01-533-0491	6	19
54786	106782-1		5315-01-532-5431	5	43
54786	106783-1		2590-01-531-5144	5	42
54786	106783-2		2590-01-531-4959	5	41
54786	106783-3		2590-01-531-4649	5	40
54786	106783-4		2590-01-532-1404	5	40
54786	106795-1		5310-01-531-4881	6	10
54786	106795-2		5306-01-532-1851	2	19
54786	106796-1		5365-01-532-2255	6	28
54786	107405-1		3465-01-531-9566	2	2
54786	107405-2		2540-01-533-0868	2	1
54786	107406-1		2540-01-533-0508	1	19
25795	11SMPPCAK-025005			7	23
	0				
54786	111403-1		5310-01-532-2541	3	5
				3	17
54786	111407-1		2540-01-532-8870	7	7
54786	111408-1		3040-01-532-6610	2	11
54786	111411-1		3120-01-532-5228	4	30
54786	111418-1		2590-01-532-1826	7	21
54786	111418-2		2590-01-532-7371	7	21
54786	111426-1		2540-01-532-8073	7	9
54786	111430-1-103		2540-01-533-0492	4	6
54786	111430-2-103		2540-01-532-8103	4	6
54786	111432-1		2540-01-532-8868	4	15
54786	111432-3		2540-01-532-8101	4	14
54786	111437-1		2540-01-532-8080	7	2
54786	111438-3		6150-01-532-6696	7	28
54786	111438-4		6150-01-532-6616	7	20

CROSS-REFERENCE INDEXES

CAGEC	PART NUMBER	PART NUMBER INDEX		FIG.	ITEM
			STOCK NUMBER		
54786	111442-1		2590-01-532-5773	7	26
54786	111444-1		5325-01-526-5340	3	15
				KITS	
54786	111451-1-103		2540-01-532-9880	5	55
54786	111451-3-103		2540-01-532-8865	5	52
54786	111453-1		5325-01-532-2185	4	24
				7	19
54786	111457-1		2540-01-532-8873	7	16
54786	111457-2		2540-01-533-0496	7	15
54786	111457-3-103		2540-01-533-0546	7	11
54786	111457-4-103		2540-01-533-0637	7	12
54786	111458-1		2540-01-533-0865	1	10
54786	111459-1		2590-01-533-0494	7	27
54786	111493-1		2540-01-533-0505	1	11
54786	111496-1		2540-01-532-8109	7	8
54786	1120A49		5330-01-531-9636	5	54
54786	113313-1		2510-01-532-7384	4	19
54786	113314-1-103		2590-01-531-7232	4	12
54786	113315-1		3040-01-531-6706	5	48
54786	113316-1		2540-01-532-8901	4	7
54786	113317-1		5365-01-532-2251	5	13
54786	113318-1		5365-01-533-0222	4	13
54786	113324-1			5	38
54786	113324-2		2590-01-532-0241	5	38
54786	113325-1		5365-01-532-0335	5	44
54786	113327-1		5340-01-531-5029	4	32
54786	113328-1		2540-01-531-5026	5	16
54786	113329-3		5340-01-531-5649	5	53
54786	113329-5		5330-01-532-9133	5	57
54786	113330-1		2540-01-530-7454	5	58
54786	113330-2		2540-01-530-7453	5	58
54786	113335-1		2540-01-531-5179	5	51
54786	113337-1		5330-01-531-9639	5	12
54786	113338-1		5365-01-533-0924	5	30
54786	113338-3		5365-01-533-0525	5	2
54786	113339-1		3040-01-532-0704	5	46
54786	113346-1		2540-01-532-8874	6	11
54786	113347-1		9520-01-532-4130	6	4
54786	113354-1-103		2590-01-533-0188	5	3
54786	113357-1		2590-01-531-6883	6	20
54786	113379-1		5340-01-533-0295	7	22
54786	113381-1		2540-01-530-7355	2	12
54786	113383-1-103		2590-01-532-0269	2	6
54786	113383-3-103		2590-01-531-7282	2	5
54786	113386-1		5340-01-532-5381	4	28
54786	113387-1		2590-01-531-5145	5	26
54786	113387-3		2590-01-532-1054	5	33
54786	113387-5		2590-01-531-5146	5	18
54786	113388-1		5340-01-532-9226	5	24
54786	113389-1		2510-01-531-5993	5	17
54786	113389-2		2590-01-531-7198	5	17

CROSS-REFERENCE INDEXES

CAGEC	PART NUMBER	PART NUMBER INDEX		FIG.	ITEM
			STOCK NUMBER		
54786	113389-2		2590-01-531-7198	5	32
54786	113389-4		2590-01-531-4966	5	32
45152	114356A		5310-00-061-4650	2	7
				3	8
				3	12
				3	20
				4	26
				6	3
54786	115506-1			5A	8
54786	115506-2			5A	8
54786	115512-1			5B	1
54786	115512-2			5B	1
54786	115563-1			5A	14
54786	115569-1			5A	19
54786	115571-1-103			5A	20
19207	11609221		5310-00-177-0973	4	3
18876	12294116-1		5310-01-110-9790	5	6
0FW39	12485124		2540-01-511-9859	5	36
39428	15665A637		2510-01-534-7342	5B	46
10001	1611203PC15		5305-00-034-1212	4	33
19220	2-300-P5		5360-01-282-9316	5B	43
27182	31-8BLK		5340-01-532-6723	5	22
39428	3126A84		5360-01-533-0285	6	21
10001	3176207-C-216			4	2
19220	400-L		2540-01-151-6209	5B	38
19220	400-R		2540-01-151-5475	5B	38
54786	437583X3/8A			5B	48
19207	443339		5310-00-044-3339	5	9
1E045	500-ZN			5	47
19220	53-5655X		2540-01-517-5300	5B	28
13499	542-1564-003		5310-01-112-4390	5	8
19220	5647-50		2540-01-534-7435	5B	27
19220	67-5655-XPKL		2540-01-531-4369	5B	25
19220	67-5655-XPKR		2540-01-531-4364	5B	25
57712	72579			5	19
19207	7402857		5310-00-188-4185	6	23
19207	7535871		5310-00-009-7682	4	10
54786	8060R D.51		5365-01-532-2111	5	15
51506	8080R S.53 5		5365-01-533-0220	6	15
1TUY2	8288		5306-00-554-4767	5	27
19220	9D-400-UL			5	35
54786	9D-400URZINC		2540-01-532-7768	5	35
39428	90086A545		5305-01-270-5365	6	9
39428	90222A419		5315-01-532-9119	5B	16
39428	90636A057		5310-01-532-9640	5B	23
39428	90692A700		5315-01-534-7440	5B	32
39428	91251A440			5A	13
39428	92562A239			5A	16
39428	93839A805		5310-01-534-7396	5B	35
39428	94773A778		5365-01-534-7362	5B	21
39428	97447A025		5320-01-534-7031	5B	12

CROSS-REFERENCE INDEXES

CAGEC	PART NUMBER	PART NUMBER INDEX		FIG.	ITEM
			STOCK NUMBER		
39428	98023A032		5310-01-533-0278	5B	22
39428	98026A029		5310-01-232-7702	5A	10
39428	98026A032			5A	6

**EQUIPMENT INSTALLATION INSTRUCTIONS AND PARTS LIST
FOR THE
HEAVY EXPANDED MOBILITY TACTICAL TRUCK (HEMTT)
CREW PROTECTION ARMOR KIT**

Contract No. W56HZV-04-C-0259
CDRL Items A001 and A002

Prepared for:

U.S. Army Tank – Automotive Command (TACOM)
AMSTA-AQ-ATBC
Warren, MI 48397-5000

Prepared by:

Simula Aerospace and Defense Group, Inc.
7822 South 46th Street
Phoenix, AZ 85044-5354
(602) 643-7233

Prepared by:	Approved by:	Approved by:
<i>/s/Quentin Jacobson 05-02-15</i>	<i>/s/George Sprague 05-02-15</i>	<i>/s/Frederick Mehtens 05-02-29</i>
Quentin Jacobson Date Project Engineer	George Sprague Date ILS / R&M Engineer	Frederick Mehtens Date Program Manager, HTV

REVISIONS				
REV	CHANGED BY	DESCRIPTION	CM RELEASE	DATE
-		Initial Release ECO 484924	/s/ Jen Celis	10-Jun-04
A	G. Sprague	Revised Per ECO 485046 Incorporated customer-requested changes to improve sealing of windows	/s/ Jen Celis	22-Jun-04
B	G. Sprague	Revised Per ECO 486385	/s/ Jen Celis	29-Mar-05

TABLE OF CONTENTS

1. INTRODUCTION	1
1.1 GENERAL.....	1
1.2 VERIFICATION OF TECHNICAL DATA	2
1.3 CRATING / UNCRATING	2
1.4 SAFETY CONSIDERATIONS	2
1.5 WARNINGS, CAUTIONS, AND NOTES	2
2. DESCRIPTION AND OPERATION.....	6
2.1 GENERAL	6
3. REMOVE EXISTING HEMTT COMPONENTS	8
4. HEMTT CREW PROTECTION ARMOR KIT INSTALLATION.....	21
4.1 EQUIPMENT AND MATERIALS	21
4.2 GENERAL INSTALLATION INSTRUCTIONS.....	21
4.3 PERSONNEL SKILL LEVEL	22
4.4 PARTS LIST	22
CREW PROTECTION ARMOR KIT ASSEMBLY PROCEDURES.....	30
5.1 INSTALL ARMOR PANELS	30
5.1.1 Install Armor Kit, Windshield, HEMTT, P/N 106701-4	30
5.1.2 Install Side Armor Protection Kit (RH), P/N 106703-10	40
5.1.3 Install the Front Armor Protection Kit, P/N 106705-3.....	43
5.1.4 Install the Headlights	46
5.1.5 Install the Armored Louvered Grille	47
5.1.6 Install the Rear Cab Armor Panels – Kit P/N 106702-3.....	48
5.1.7 Install the LH and RH Armored Door Assembly – Side Armor Kit P/N 106703-9 (Driver’s-side) and P/N 106703-10 (Passenger-side).....	51
5.1.8 Install the LH and RH Rear Side Cab Armor Panel, Kit P/N 106703-9 (LH) and P/N 106703-10 (RH).....	57
5.1.9 Install the Blast Deflectors, Kit P/N 106706-3 (see Figure 36)	60
5.1.10 Install the Roof Armor, Kit P/N 106704-3.....	70
5.1.11 Re-Install the LH and RH Door-Mounted Outside Mirrors	79
5.1.12 Re-Install the Cab Steps (with the Internal Clearance Light).....	79
5.1.13 Re-install the Blackout Light	79

5.1.14 Re-Install the Bridge Weight Sign.....	79
5.1.15 Re-install the Tow Shackles	80
5.1.16 Re-install the Machine-Gun Mount (if required).....	81
APPENDIX A	82

LIST OF ACRONYMS AND ABBREVIATIONS

ft-lb	foot-pounds
HEMTT	Heavy Expanded Mobility Tactical Truck
IED	Improvised Explosive Device
in.	inch
mm	millimeter
MIL-SPEC	Military Specification
P/N	Part Number

1. INTRODUCTION

1.1 GENERAL

This document provides the Installation Instructions for the Crew Protection Armor Kit for the M977 Series, 8 X 8 Heavy Expanded Mobility Tactical Truck (HEMTT). This Kit, which was manufactured by Simula Aerospace and Defense Group, Inc. (Simula), is composed of various armor panels that can be easily attached and detached from the HEMTT and stored in dedicated storage containers when they are not required.

This Kit provides the HEMTT with improved ballistic protection against mines, improvised explosive devices (IEDs), light artillery fragments, and 7.62-mm Ball projectiles. The Kit consists of Right, Left, and Center Blast Deflectors; Front, Side, Rear, and Roof Cab Armor Panels; Armored Doors; Radiator Grille Armor; Windshield and Side Window Armor, and an Armored Escape Hatch (See Figure 1).

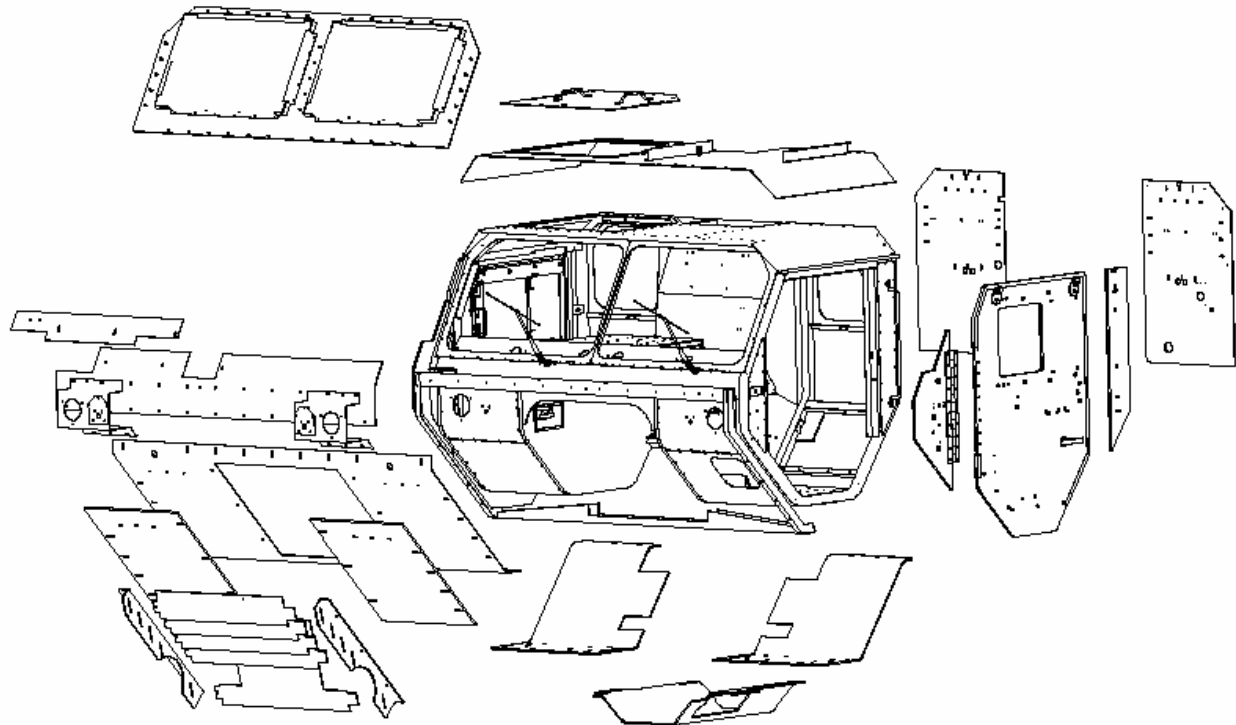

Figure 1. HEMTT Crew Protection Armor Kit component location.

1.2 VERIFICATION OF TECHNICAL DATA

This Manual's procedures have been validated by field installation of the Armor Kit on HEMTT vehicles accomplished in December of 2004.

1.3 CRATING / UNCRATING

Each Kit will be contained within approved shipping containers. These containers will provide the Kit's armor panels with protection and security when they are not installed on the HEMTT. Because of the weight of the specific armor panels within the Kit, care should be taken during removal of the panels from the containers or replacement of the panels back into the containers. Two personnel and mechanical aids (hoist, forklift, etc.) are required during the removal / installation of the armor panels.

1.4 SAFETY CONSIDERATIONS

The weights of the majority of the components within the Kit are heavier than allowable for one or two personnel, and the metal armor components may have sharp edges. Appropriate lifting and safety equipment, manpower, and safety precautions shall be utilized to ensure that no injuries are incurred during the installation or removal of the armor panels onto the HEMTT or during the removal or replacement of the panels into the shipping containers. Warnings, Cautions, and Notes are provided in these Installation Instructions, as appropriate, to advise the maintenance personnel of information necessary for the installation or removal of Kit components (see Figures 1-1 and 1-2).

1.5 WARNINGS, CAUTIONS, AND NOTES

Warnings, Cautions, and Notes are included in these Installation Instructions to provide short, concise statements that emphasize critical or important information. Warnings, Cautions, and Notes precede the text that they affect, but follow the paragraph headings to which they apply. Warnings precede Cautions, and Cautions, in turn, precede Notes. A format example and an explanation of the function of each are provided below.

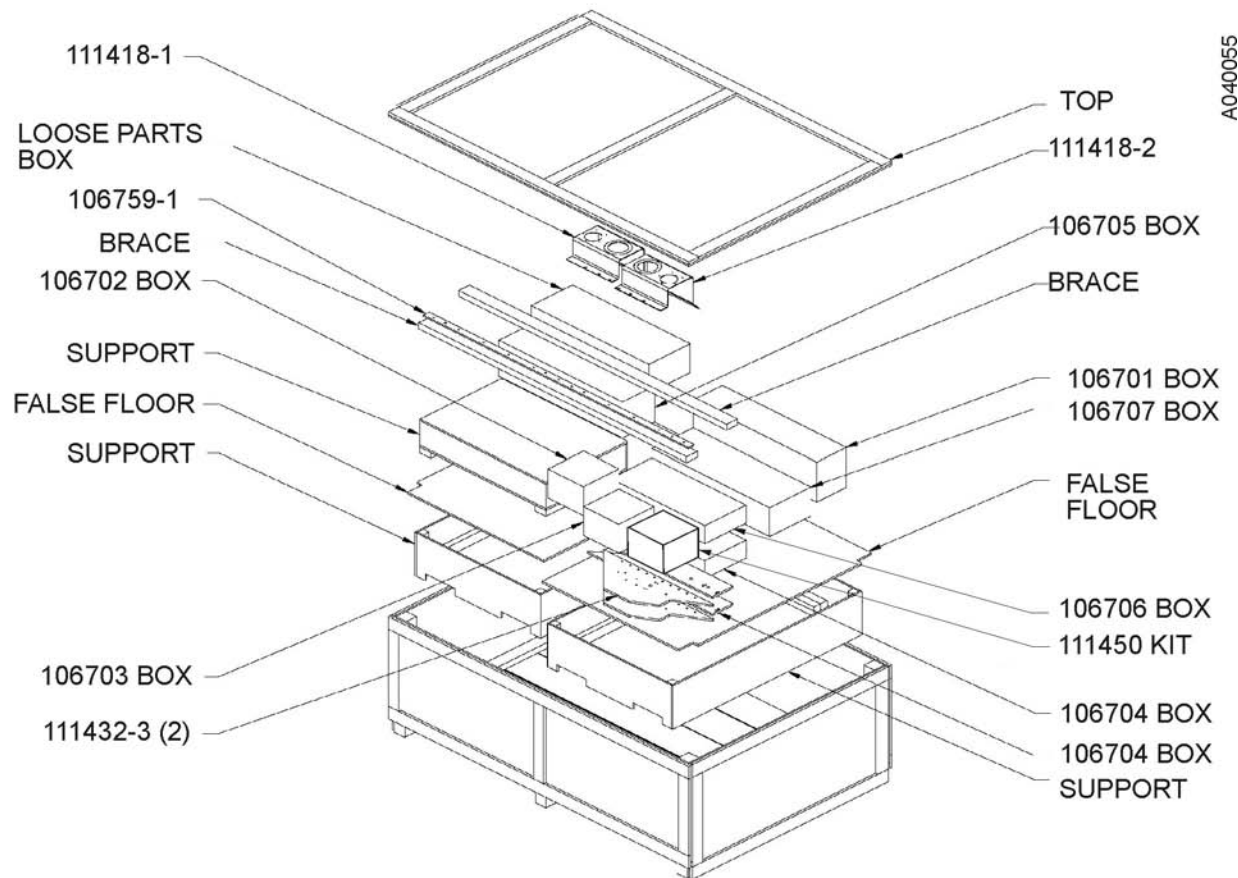

Figure 1-1. Crate No. 1 layout.

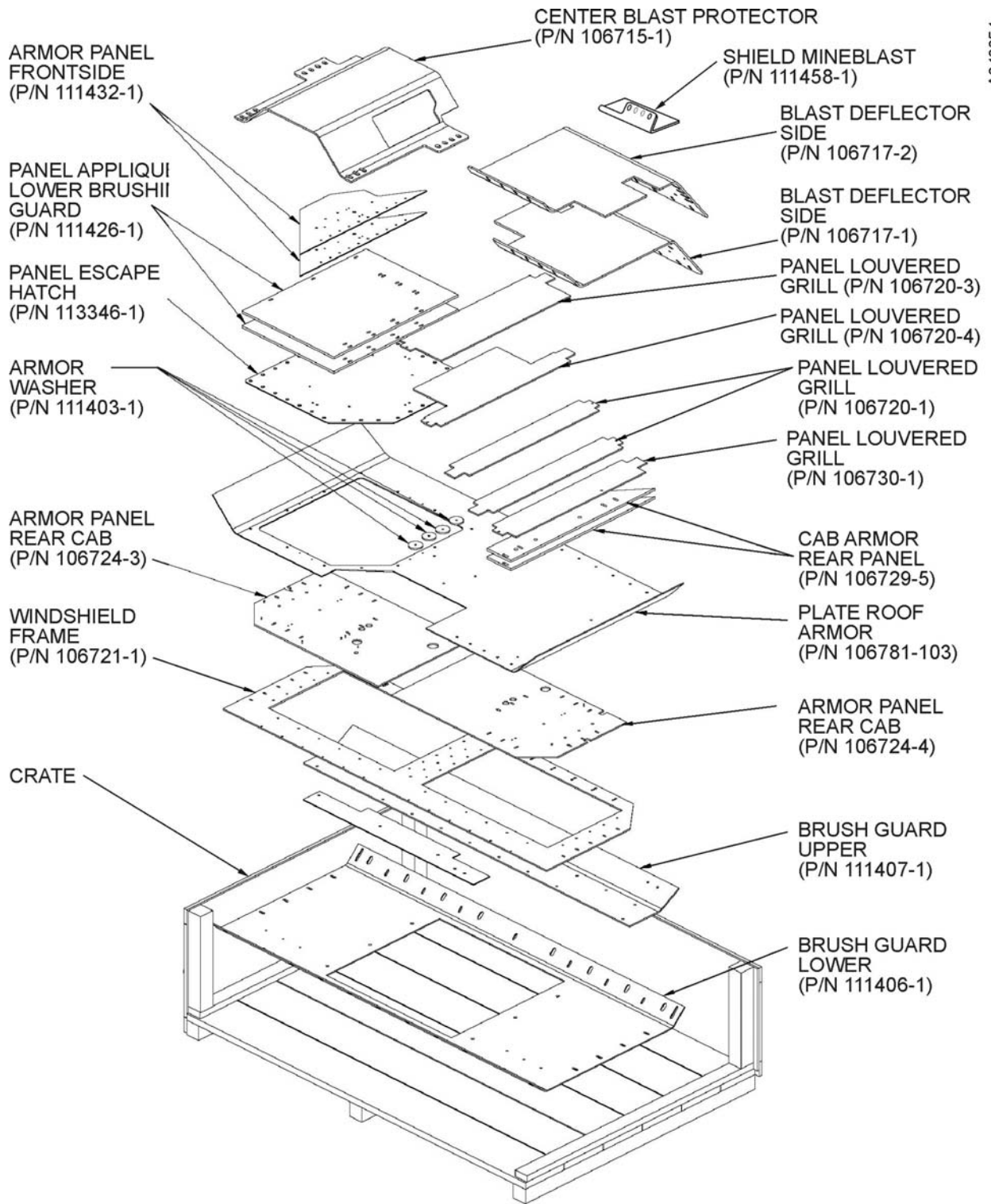

Figure 1-2. Crate No. 2 layout.

WARNING

WARNINGS HIGHLIGHT AN OPERATING OR MAINTENANCE PROCEDURE, PRACTICE, CONDITION, STATEMENT, ETC., WHICH, IF NOT STRICTLY OBSERVED, COULD RESULT IN INJURY TO PERSONNEL OR LOSS OF LIFE.

CAUTION

Cautions highlight an operating or maintenance procedure, practice, condition, statement, etc., which, if not strictly observed, could result in damage to, or destruction of, equipment, loss of mission effectiveness, or long-term health hazards to personnel.

NOTE

Notes highlight an essential operating or maintenance procedure, condition, or statement.

2. DESCRIPTION AND OPERATION

The physical characteristics of the HEMTT Crew Protection Armor Kit are listed in Table 1.

Table 1. HEMTT Crew Protection Armor Kit components				
Part Description	Part Number (P/N)	Weight of Part (lb)	Quantity Per Vehicle	Total Weight Per Vehicle (lb)
Windshield Frame	106721-1	123.00	1	123.00
Windshield Assy	113381-1	112.87	2	225.74
Upper Brush Guard	111407-1	131.00	1	131.00
Lower Brush Guard	111496-1	219.00	1	219.00
Louvers	111457-1, -2, -3, -4	149.00	1	149.00
Front Side Panels	111432-1, -3	31.00	2	62.00
Door	111430-1, -2	336.40	2	672.80
Roof Armor	106781-3	166.00	1	166.00
Roof Hatch Armor	113342-1	61.00	1	61.00
Cab Rear Armor	106724-3, -4	100.20	2	200.40
Blast Deflector LHS	106717-1	145.00	1	145.00
Blast Deflector RHS	106717-2	145.00	1	145.00
Blast Deflector Center	106715-1	147.00	1	147.00
Cab Rear Side Armor	106729-3	27.00	2	54.00
Upper Brush Guard Shim	106759-1	6.55	1	6.55
Headlight Bracket	111418-1, -2	12.60	2	25.20
Brackets, Mounts, Etc.	MISC.	225.00	1 Lot	225.00
Cover, Upper Brush Guard	111437-1	26.50	1	26.50
Panel Applique Lower Brush Guard	111426-1	49.90	2	99.80
Total Kit Weight				2,883.99
PARTS TO BE REMOVED				
Doors	-	100.00	2	200.00
Brushguard	-	112.00	1	112.00
Rear Windows	-	8.50	2	17.00
Windshield (each)	-	32.10	2	64.20
Total Weight Removed				393.20
TOTAL WEIGHT IMPACT				+2,490.79

2.1 GENERAL

The HEMTT Crew Protection Armor Kit consists of two Armored Doors, Roof Armor, Transparent Windshield Armor, Three Blast Deflectors, One Upper and One Lower Brush Guard, Forward and Rear Side Armor Panels, Rear Cab Armor Panels, an Armored Louvered Grille Assembly, and an Armored Escape Hatch.

The Door Armor Attachment Assembly consists of an Armor Panel Bracket that is mounted to the existing door frame and is bolted in place of the existing door's hinge. The Armored Door Assembly (which incorporates a sliding armored window) is bolted to the Hinge Assembly on the Armor Panel. The Roof Armor Panel is installed using the existing bolt hole pattern (used for the Machine Gun Mount) on the roof on the passenger side and the Mounting Brackets (front

and rear) on the driver's side. The Roof Armor is a one-piece panel that requires material handling equipment (hoist, forklift, etc.) for installation due to its weight. The windshield and side windows are constructed of transparent armor. The remaining armor panels are fastened to the vehicle using attachment brackets and hardware.

NOTE: If the vehicle is equipped with, or will be equipped with, C4ISR gear, use the Installation Instruction II111450 contained in the C4ISR equipment box labeled 111450-KIT.

3. REMOVE EXISTING HEMTT COMPONENTS

WARNING

THE EXISTING HEMTT DRIVER AND PASSENGER DOORS, SKID PLATE, AND SPARE TIRE ARE HEAVY ITEMS THAT REQUIRE TWO PERSONNEL OR ONE PERSONNEL AND APPROPRIATE MATERIAL HANDLING EQUIPMENT (HOIST, FORKLIFT, ETC.) FOR HANDLING. THE WEIGHTS OF THE COMPONENTS TO BE REMOVED ARE SUFFICIENT TO CAUSE SERIOUS INJURY OR LOSS OF LIFE. CARE MUST BE TAKEN DURING REMOVAL TO PREVENT INJURY.

HOISTING OPERATIONS HAVE INHERENT HAZARDS THAT CANNOT BE MECHANICALLY SAFE-GUARDED. PERSONNEL ARE REQUIRED TO WEAR HARD HATS AND SAFETY SHOES DURING THE USE OF MATERIAL HANDLING EQUIPMENT TO PREVENT PERSONAL INJURY.

NOTE

Bag and tag all removed hardware to contain it and aid in re-installation of the removed components. See Figure 2 and the accompanying table for the existing HEMTT components that need to be removed and retained for either re-use with the new armor kit or replacement when the armor kit is removed.

1. Remove the Machine-Gun Mount.
 - a. Attach material handling equipment (hoist, forklift, etc.) to the top ring.
 - b. Remove the two nuts, bolts, and washers from the mounting brackets (two front and one rear bracket).
 - c. Remove the Machine-Gun Mount from the vehicle.
2. Remove the Driver-Side and Passenger-Side Doors.
 - a. Attach material handling equipment (hoist, forklift, etc.) to the top of the Door to support its weight during the removal process.
 - b. Remove two screws (Item 4 in Figure 3) two washers (5), and the spacer (7) securing the Doorstrap (2) to the Door Frame (6). It is not necessary to remove the two screws (1) that secure the Doorstrap (2) to the cab.
 - c. While one person holds the door, have another person remove the ten bolts (9) from the hinge point on the vehicle.
 - d. Remove the Door (8) and the Door Hinge (10) from the vehicle.



Figure 2. Existing HEMTT components that are removed and retained.

Removed HEMTT components to be retained	
Item Removed	Number of Items
Headlights	2 ea
Front Marker Lights	2 ea
Grab Handles – Side Cab	2 ea
Side Mirrors	2 ea
Clevis	2 ea
Steps – Cab	2 ea
Cab Step Lights	2 ea
Bridge Weight Sign	1 ea
Side Cab Reflector	2 ea
Windshield Wiper	2 ea
VIN / Weight Plates	1 ea (Driver's door)
Gun Ring Components	(If equipped)
Blackout Light / Bracket	1 ea

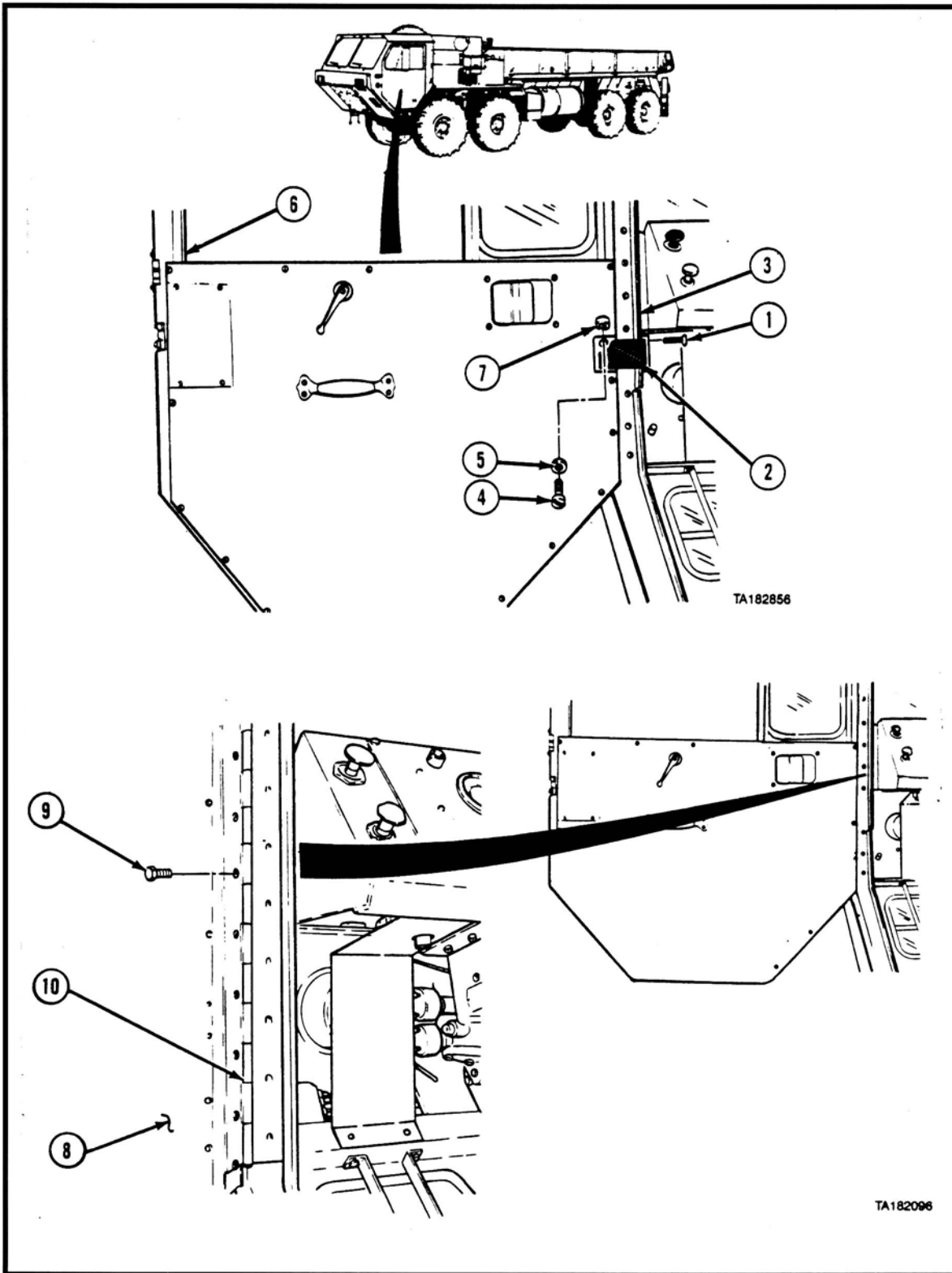

Figure 3. HEMTT Door removal.

3. Remove the Male Dovetail and the Striker from the Door Frame of the Driver-Side and Passenger-Side Doors.
 - a. Remove the two screws (Item 18 in Figure 4) that secure the Male Dovetail (19) to the Door Frame (3), and then remove the Male Dovetail from the Door Frame.
 - b. Remove the nut (16) and remove the Striker (17).

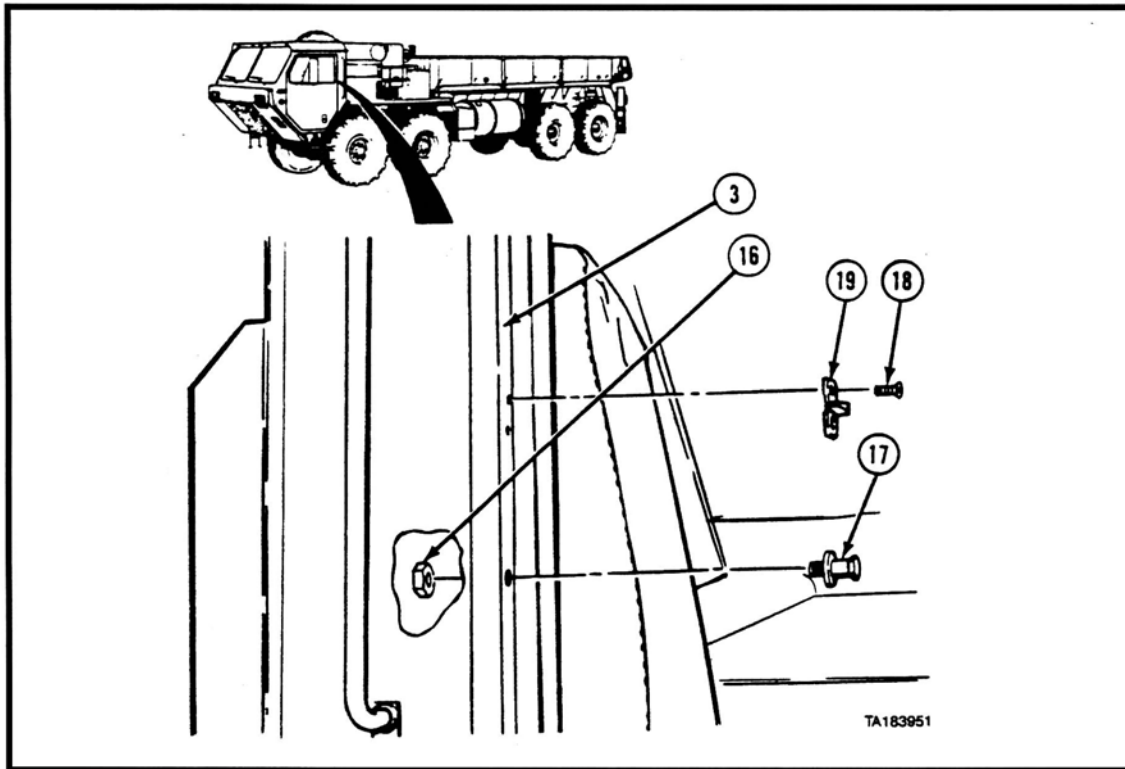

Figure 4. Remove the Male Dovetail and the Striker from the Door Frame.

4. Remove the door-mounted Outside Mirrors from the Driver's-Side and Passenger-Side Doors.
 - a. Remove the six bolts, flat washers, and nuts that secure the mirror and frame to both the Driver-Side and Passenger-Side Doors and remove the Outside Mirror from the Door.
5. Remove the Towing Shackles.
 - a. Remove the cotter pins and retaining pins that attach the Towing Shackles to the frame ends, and then remove the Towing Shackles.
6. Remove the Skid Plate from the lower front portion of the cab.
 - a. Remove nine screws (Item 1 in Figure 5) and nuts (2) from the Skid Plate.

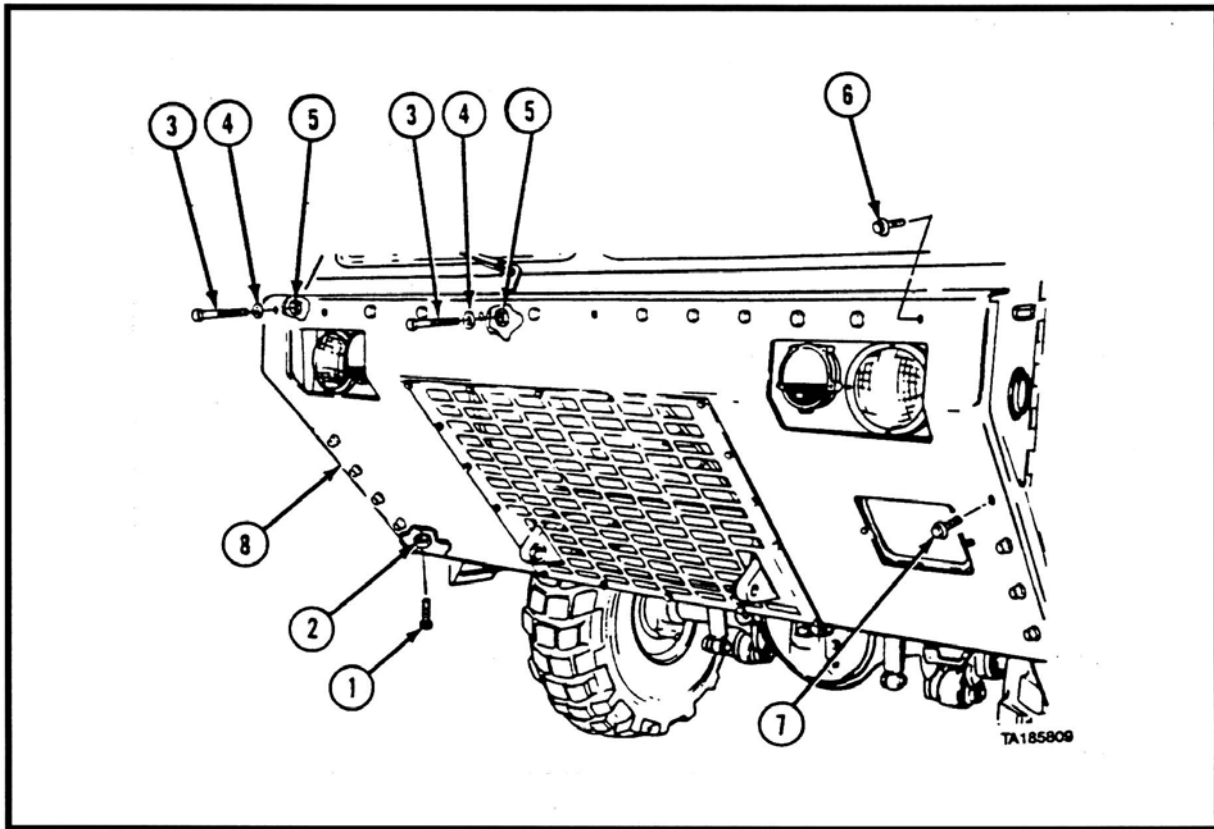

Figure 5. Removing the Skid Plate.

- c. Remove two screws (3), washers (4), and nuts (5) from the Skid Plate.
 - d. Remove 15 of the 17 screws (6, 7) from the Skid Plate (8), loosening but leaving in two screws (6), one on each side, at the top edge of the Skid Plate (8).
 - e. While two personnel hold the Skid Plate, remove the two remaining screws (6), and remove the Skid Plate (8).
7. Remove the Blackout Light and Bracket.
 - a. Remove mounting bolt, nut, and washer.
 - b. Unplug wire and remove the Blackout Light and Mounting Bracket.
 8. Remove the Bridge Weight Sign from the Skid Plate.
 - a. Working from the back surface of the Skid Plate, remove the two bolts, lockwashers, and flat washers that secure the Bridge Weight Sign to the skid plate, and then remove the Bridge Weight Sign from the Skid Plate.
 9. Remove the Side Grab Handle from each side of the cab.

- a. Remove the two nuts (Item 6 in Figure 6), lockwashers (7), flat washers (8), and bolts (9) that secure the Side Grab Handle to the cab, and then remove the Side Grab Handle from the cab.

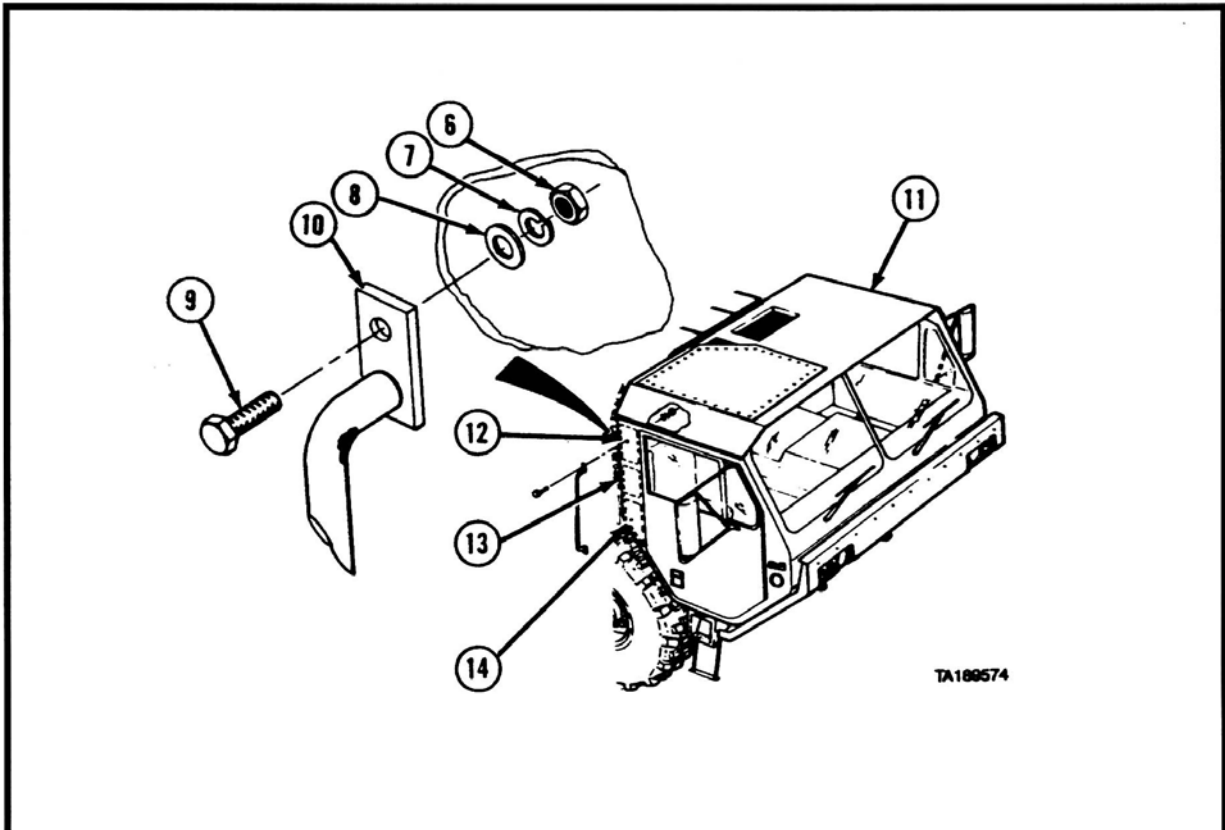

Figure 6. Remove the Side Grab Handles.

10. Remove the Headlights (LH, RH).
 - a. Remove the three screws (8) that secure the Headlights to the cab (LH, RH). Retain the hardware for the re-installation of the Headlights.
 - b. Unplug the Headlights from the wiring harness, and retain the Headlights for subsequent re-installation.
11. Remove the Marker Lights (LH, RH).
 - a. Remove the five screws (9) that secure the Marker Lights to the cab (LH, RH). Retain the hardware for the re-installation of the Marker Lights.
 - b. Unplug the Marker Lights from the Wiring Harness, and retain the Marker Lights for subsequent re-installation.
12. Remove the Cab Step (with the integral Clearance Light) from both sides of the cab.
 - a. Remove the four screws (Item 5 in Figure 7) and lockwashers (6) from the Cab Step (4), and remove the Cab Step (4) from the bottom of the cab (7).

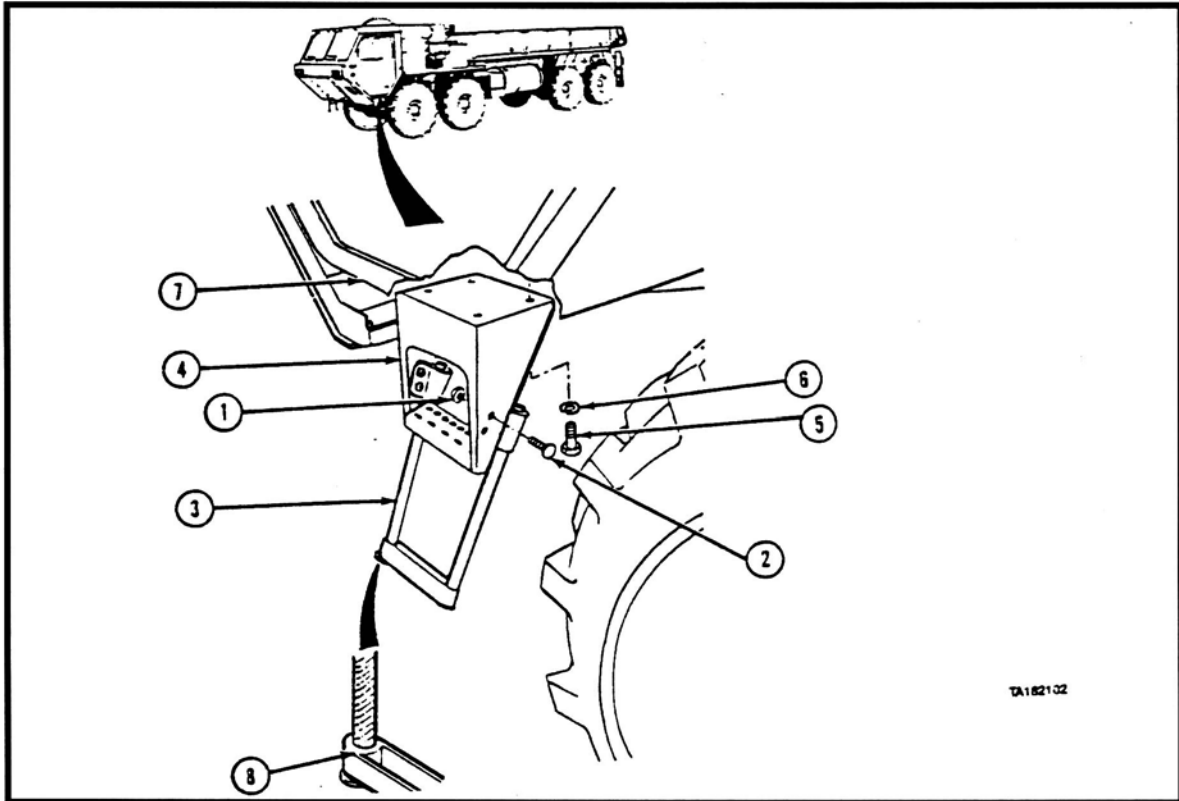

Figure 7. Remove the Cab Step.

- b. Unplug the integral Clearance Light from the wiring harness.
 - c. Remove the four nuts (1) and screws (2) and separate the flexible step (3) from the Cab Step (4).
13. Remove the Cab Side Clearance Lights and Reflectors from both sides of the cab.
- a. Remove the two screws that secure the amber lens of the Cab Side Clearance Light that is located on the front forward end of both sides of the cab.
 - b. Remove the four mounting screws of the Cab Side Clearance Light base and separate the Cab Step Clearance Light base from the Cab Step.
 - c. Position the Cab Step Clearance Light and wiring under the cab away from the cab armor installation areas.
 - d. Remove the two screws that secure the amber Reflectors located on the front forward sides of the cab. Remove the amber Reflectors.
14. Remove the Cab Top Clearance Light Bar.

- a. From the inside of the cab, cut the Cab Top Clearance Light Bar wire lead (Lead Number 12) 6 in. from the exit hole. Install a closed-end wire connector on the end of the wire (inside the cab), fold the wire inward, and secure it in place with a wire tie.
 - b. Remove the six screws holding the Cab Top Clearance Light Bar to the cab roof overhang at the top of the windshield, and remove the Cab Top Clearance Light Bar from the vehicle.
15. Loosen the Tire Carrier.
- a. Remove the spare tire (per TM 9-2320-279-10).
 - b. Remove the four screws (Item 22 in Figure 8), nuts (23), and lockwashers (24) from the Tire Carrier (18) and Fender (25).
 - c. Remove the two screws (26), nuts (27), and lockwashers (28).
 - d. Remove the mounting bolts, nuts, and washers from the fuel-air separator guard (See Figure 9).
 - e. Slide the tire carrier out to provide access to the rear window (See Figure 10).

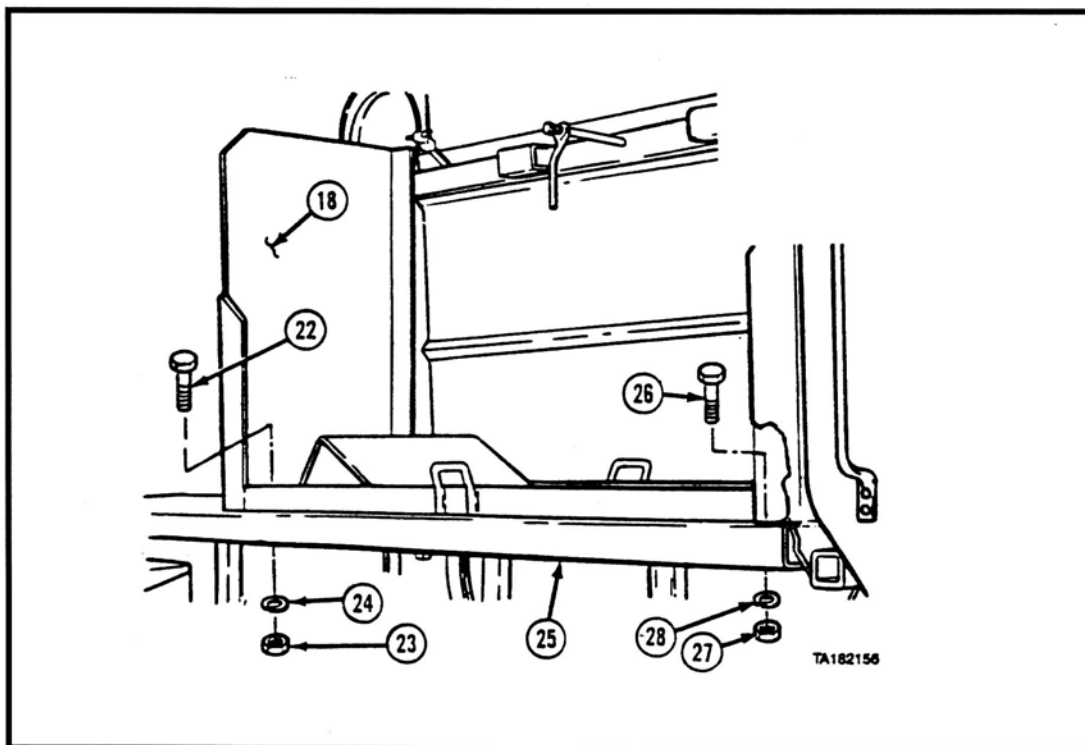

Figure 8. Loosen the Tire Carrier.

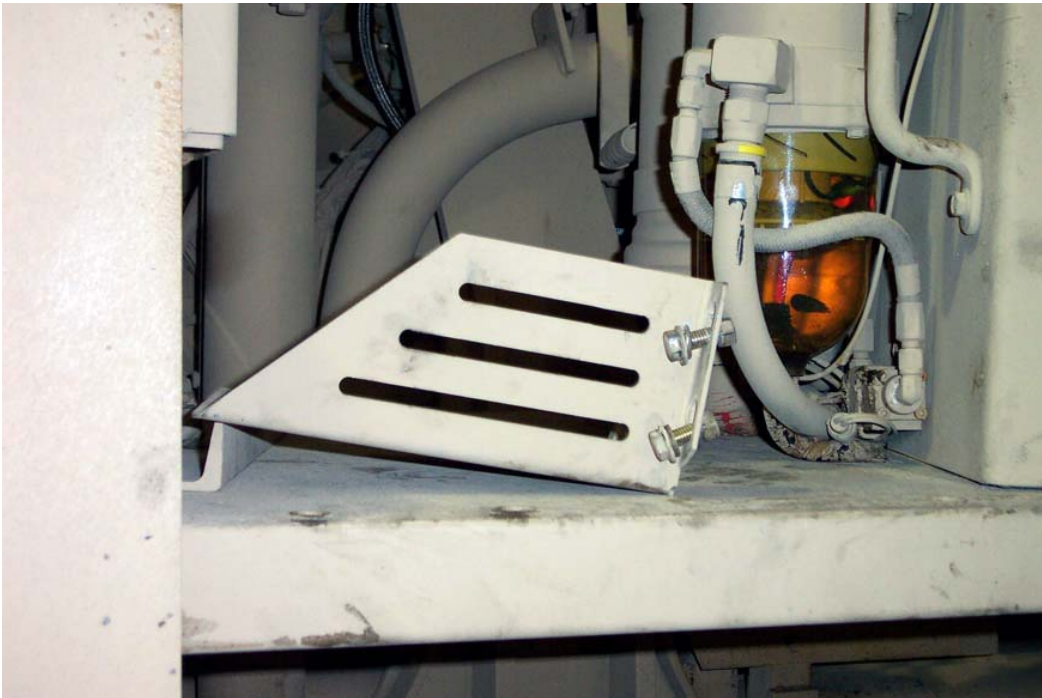

Figure 9. Remove the Fuel-Air Separator Guard.



Figure 10. Slide out the Tire Carrier.

16. Remove the windshield wipers and windshield halves.

WARNING

THE WINDSHIELD GLASS CAN BREAK UNEXPECTEDLY DURING THE REMOVAL / INSTALLATION PROCESS. PERSONNEL ARE REQUIRED TO WEAR A FACE SHIELD, APRON, AND GLOVES.

- a. Remove the nut (Item 7 in Figure 11) and lock washer (8) from the driver's-side windshield wiper drive shaft.

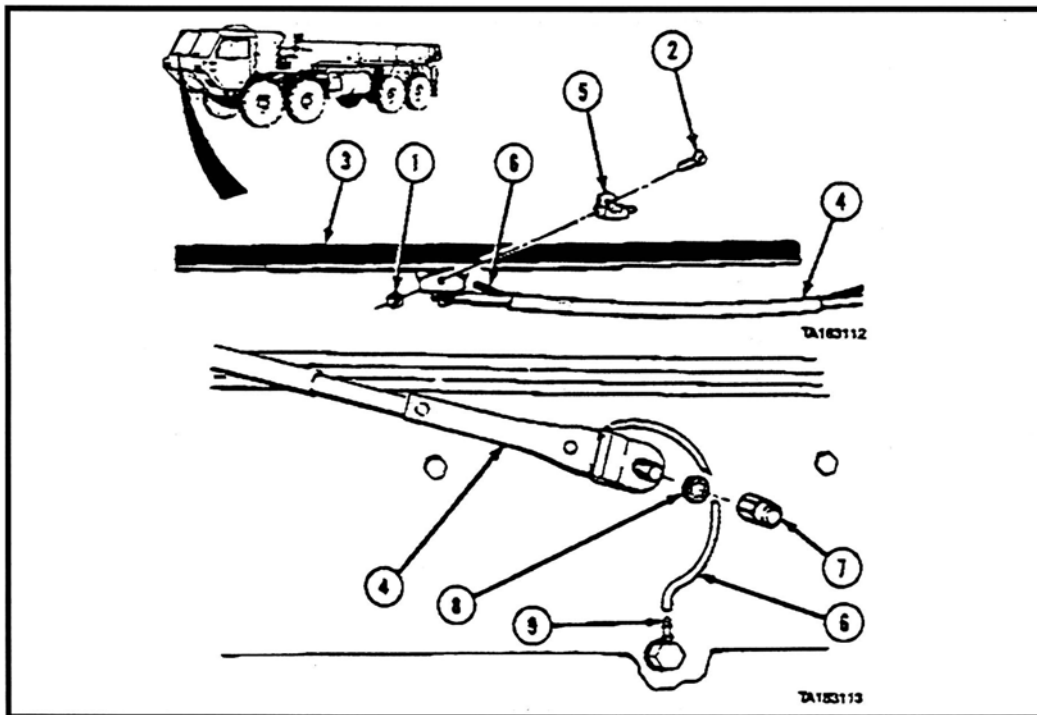

Figure 11. Remove the windshield wiper.

- b. Disconnect the hose (6) from the nipple (9) and then remove the driver's-side windshield wiper and arm from the vehicle.
- c. Remove the windshield weatherstripping locking strip from the center of the weatherstripping on the driver's-side windshield half.
- d. From the outside of the windshield, carefully fold the inside edge of the weatherstripping out around the driver's-side windshield half.
- e. With one person inside the vehicle pushing on the windshield half and one person on the outside to steady the windshield half, remove the driver's-side windshield half from the vehicle (see Figure 12).
- f. Repeat Steps 15a through 15e to remove the passenger-side windshield wiper and windshield half.



NN517

Figure 12. Remove the windshield half.

17. Remove the Rear Cab Windows.

WARNING

THE REAR CAB WINDOW GLASS CAN BREAK UNEXPECTEDLY DURING THE REMOVAL / INSTALLATION PROCESS. PERSONNEL ARE REQUIRED TO WEAR A FACE SHIELD, APRON, AND GLOVES.

- a. Remove the Rear Cab Window weatherstripping locking strip from the center of the weatherstripping on one of the Rear Cab Windows.
- b. From the outside of the Rear Cab Window, carefully fold the inside edge of the weatherstripping out around the Rear Cab Window.
- c. With one person inside the vehicle pushing on the Rear Cab Window and one person on the outside to steady the Rear Cab Window, remove the Rear Cab Window from the vehicle (See Figure 13).
- d. Repeat Steps 16a, 16b, and 16c to remove the remaining Rear Cab Window.



Figure 13. Remove the Rear Cab Window.

18. Remove the Passenger-Side Roof Panel (Machine-Gun Mount) Attachment Bolts.
 - a. Remove the 34 bolts (Item 1 in Figure 14) that secure the Passenger-Side Roof Panel to the HEMTT roof and remove the Passenger-Side Roof Panel.

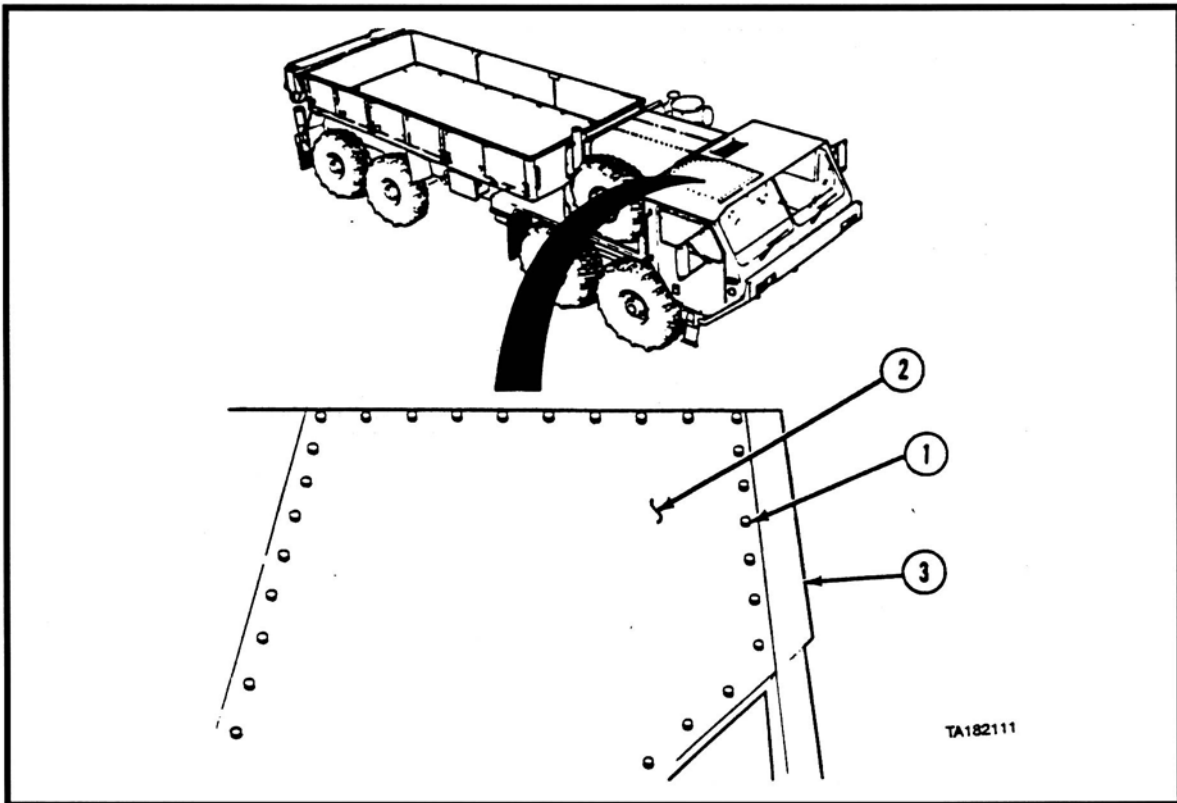

Figure 14. Remove the Passenger-Side Roof Panel (Machine-Gun Mount) Attachment Bolts.

4. HEMTT CREW PROTECTION ARMOR KIT INSTALLATION

4.1 EQUIPMENT AND MATERIALS

The equipment and materials required to install the Crew Protection Armor Kit onto the HEMTT are provided in Table 2.

Table 2. Equipment and Materials required to install the Crew Protection Kit	
Description	Part Number
Automotive General Mechanics Tool Kit	SC5180-90-N26
2.5-Ton Floor Jack	Commercially Available
8-in. C-Clamps	Commercially Available
Fork Lift / Overhead Hoist	Commercially Available
1/2-in. Drill	Commercially Available
1/2-in. Right-Angle Drill	Commercially Available
3/16-, 1/4-, 7/16-, 9/16-, 17/32-in. Drill Bits	Commercially Available
3/8-in. Drill Bit	Commercially Available
1/2-in., 5/8-in. Drill Bits	Commercially Available
Loctite 242 (Blue)	Commercially Available
Wire Ties	Commercially Available
Caulking Gun	Commercially Available
Lift Straps	Commercially Available
3/8-in.-Drive 0-90 ft-lb Torque Wrench	Commercially Available
1/2-in.-Drive 0-150 ft-lb Torque Wrench	Commercially Available
3/4-in.-Drive 0-280 ft-lb Torque Wrench	Commercially Available
5/16-in. – 18 Rivnut Installation Tool	AKPT518TAK or equivalent - Commercially Available
3/8-in. – 16 Rivnut Installation Tool	AKPT616TAK or equivalent - Commercially Available
1/4-in. – 3/4-in. Uni-Bit	Commercially Available
#50 Torx Socket	Commercially Available

4.2 GENERAL INSTALLATION INSTRUCTIONS

NOTE

These Installation Instructions will provide the illustration directly after that installation callout, and the text will be on either the same page or the facing page, where practical. All necessary information, torque values, tool numbers, and materials used will be provided so that the unit can be assembled without reference to another part of the installation instructions. **Prior to installation, check the envelope on the back cover for any supplemental instructions. Any variant configurations may require alternate fastener lengths. These fasteners are found in the Extra Fastener Kit, P/N 111444.**

- a. Before beginning the assembly of a part, remove all corrosion-preventative compound (if any) and any accumulated foreign matter.
- b. All nuts, bolts, and screws used in the installation of the Kit must be coated with Loctite 242 thread lock adhesive and tightened to standard torque values, unless otherwise stated. The locknuts supplied with the Kits do not require Loctite 242. A list of standard thread / pitch sizes and the corresponding torque values are provided in Appendix A.

- c. The following alphabetical characters are not used in this manual to eliminate their potential confusion with other numbers or letters: i, j, l, o, and q.

4.3 PERSONNEL SKILL LEVEL

The installation skill level required to complete the installation of the Kit shall be MOS 63S, Heavy Wheel Vehicle Mechanic.

4.4 PARTS LIST

The HEMTT Crew Protection Armor Kit, P/N 106700-5, is composed of 12 items as follows:

Item No.	Name	Part Number	Quantity
1	Underbody Armor Protection Kit	106706-3	1
2	Installation Kit	106707-2	1
3	Windshield Armor Protection Kit	106701-4	1
4	Rear Cab Armor Protection Kit	106702-3	1
5	Rear Cab Armor Protection Kit	106702-4	1
6	Side Armor Kit (LH)	106703-9	1
7	Side Armor Kit (RH)	106703-10	1
8	Roof Armor Protection Kit	106704-3	1
9	Front Armor Protection Kit	106705-3	1
10	Fastener Kit, Extra	111444-1	1
11	Installation Instructions	II106700-5	1
12	C4ISR Mounting Hardware Kit	111450-1	1

The Underbody Armor Protection Kit, P/N 106706-3, consists of the following parts:

Item No.	Name	Part Number	Quantity
1	Center Blast Deflector	106715-1	1
2	Blast Deflector, LH	106717-1	1
3	Blast Deflector, RH	106717-2	1
4	Doubler	106719-1	6
5	Bracket	106753-1	1
6	Bracket	106754-1	1
7	Spacer	106777-1	1
8	Threaded Plate	106778-1	2
9	Bolt, Hex Head, GR8, 5/16 - 18 x 1.500 LG	-	8
10	Bolt, Hex Head, GR8, 3/8 - 16 x 2.000 LG	-	9
11	Bolt, Hex Head, GR8, 1/2 - 13 x 1.500 LG	-	8
12	Bolt, Hex Head, GR8, 0.750 - 10 x 2.500 LG	-	6
13	Bolt, Hex Head, GR8, 0.750 - 10 x 4.500 LG	-	4
14	Nut, Hex, Self-Locking, GRC, 5/16 - 18	-	8
15	Nut, Hex, Self-Locking, GRC, 3/8 - 16	-	9
16	Washer, 5/16 ID	-	16
17	Washer, 3/8 ID	-	18
18	Washer, 1/2 ID	-	8
19	Washer, 0.750 ID	-	38
20	Nut, Hex, Self-Locking, GR8, 0.750-10	-	20
21	Bolt, Hex Head, GR8, 0.750 - 10 x 2.000 LG	-	8
22	Shield, Mine Blast	111458-1	1
23	Radius Block, Mine Blast	111493-1	1

The Installation Kit, P/N 106707-2, includes two alignment studs for the Brush Guard Armor, and consists of the following parts:

Item No.	Name	Part Number	Quantity
1	Stud	107430-1	2
2	Template, Side Blast Deflector	107406-1	1
3	Template, Side Windshield	107405-2	1
4	Template, Side Windshield	107405-1	1

The Windshield Armor Protection Kit, P/N 106701-4, consists of the following parts:

Item No.	Name	Part Number	Quantity
1	Decal	104301-1	2
2	Urethane, Sealant	104302-1	31.5 oz
3	Sealer, Ribbon	104303-1	15 ft
4	Frame, Windshield	106721-1	1
5	Bracket	106733-1	1
6	Bracket	106734-1, Alt. -5	2
7	Bracket	106734-2, Alt. -6	2
8	Bracket	106734-3, Alt. -7	2
9	Bracket	106746-1	2
10	Armor, Windshield Assembly	113381-1	2
11	Bolt, Hex Head, GR8, 1/4 - 20 x 1.750 LG	-	5
12	Bolt, Hex Head, GR8, 1/4 - 20 x 1.000 LG	-	32
13	Bolt, Hex Head, GR8, 1/4 - 20 x 0.750 LG	-	34
14	Nut, Hex, Self-Locking, GRC, 1/4 - 20	-	96
15	Washer, 1/4 ID	-	133
16	Bolt, Eye	106795-2	2
17	Washer, 3/8 ID	-	2
18	Nut, Hex, Self-Locking, GR8, 3/8 - 16	-	2
19	Extension, Windshield Wiper Shaft	111408-1	2
20	Z-Channel, Windshield Mount	113383-1	4
21	Z-Channel, Windshield Mount	113383-3	4
22	Set Screw, 10-32 x 313L	1032SSCFP-0190031	2

The Rear Cab Armor Protection Kit, P/N 106702-3, consists of the following parts:

Item No.	Name	Part Number	Quantity
1	Bracket	106734-4	4
2	Bolt, Hex Head, GR8, 1/4 - 20 x 0.750 LG	-	12
3	Nut, Hex, Self-Locking, GRC, 1/4 - 20	-	14
4	Washer, 1/4 ID	-	14
5	Washer, 3/8 ID	-	14
6	Armor Panel Assembly	106724-3	1
7	Washer, Armored	111403-1	2
8	Bolt, Hex Head, GR8, 1/4 - 20 x 1.500 LG	-	2
9	Washer, Fender, 1/4 x 1.500 O.D.	-	2

The Rear Cab Armor Protection Kit, P/N 106702-4, consists of the following parts:

Item No.	Name	Part Number	Quantity
1	Bracket	106734-4	4
2	Bolt, Hex Head, GR8, 1/4 - 20 x 0.750 LG	-	12
3	Nut, Hex, Self-Locking, GRC, 1/4 - 20	-	13
4	Washer, 1/4 ID	-	13
5	Washer, 3/8 ID	-	13
6	Armor Panel Assembly	106724-4	1
7	Washer, Armored	111403-1	1
8	Bolt, Hex Head, GR8, 1/4 - 20 x 1.500 LG	-	1
9	Washer, Fender, 1/4 x 1.500 O.D.	-	2

The C4ISR Mounting Hardware Kit, P/N 111450-1, consists of the following parts:

Item No.	Name	Part Number	Quantity
1	Plate Assembly, MTS Bracket	111449-1	1
2	Bracket, PLGR Antenna Mount	111452-1	1
3	Bolt, Hex Head, GR8, 1/4 - 28 x 1.000 LG	-	2
4	Nut, Self-Locking, GRC, 1/4 - 20	-	9
5	Nut, Self-Locking, 10 - 24	-	8
6	Washer, GR8, 1/4 ID	-	11
7	Washer, GR8, No. 10	-	8
8	Installation Instructions, C4ISR Mounting Hardware Kit	II111450-1	1
9	Nut, 1/4 - 28	-	2
10	Bolt, Hex Head, GR8, 1/4 - 20 x 0.750 LG	-	2

The Side Armor Kit (LH), P/N 106703-9, consists of the following parts:

Item No.	Name	Part Number	Quantity
1	Washer, 3/16 x 0.063T	-	8
2	Washer, Lock, 3/16 ID	-	4
3	Bolt, Hex Head, GR8, 1/4 - 20 x 1.000 LG	-	4
4	Nut, Hex, Self-Locking, GR8, 1/4 - 20	-	2
5	Nut, Hex, Self-Locking, GR8, 3/8 - 16	-	25
6	Washer, 1/4 ID	-	10
7	Screw, Socket Head, 3/16 - 24 x 1.250 LG	-	4
8	Nut, Plain, 3/16 - 24	-	4
9	Bolt, Hex Head, GR8, 1/4 - 20 x 1.750 LG	-	4
10	Bolt, Hex Head, GR8, 5/16 - 18 x 1.500 LG	-	10
11	Bolt, Hex Head, GR8, 3/8 - 16 x 2.000 LG	-	4
12	Bolt, Hex Head, GR8, 3/8 - 16 x 1.500 LG	-	14
13	Washer, 5/16 ID	-	21
14	Washer, 3/8 ID	-	46
15	Decal	104301-1	1
16	Spacer, 0.4 Thick	113318-1	4
17	Cab Armor, Rear Panel (AL)	106729-5	1
18	Cab Armor, Front Panel (AL)	111432-3	1
19	Bolt, Hex Head, GR8, 3/8 - 16 x 3.000 LG	-	4
20	Cab Armor, Front Panel (ST)	111432-1	1
21	Cab Armor, Rear Panel (ST)	106729-3	1
22	Bolt, Hex, Head, GR8, 3/8 - 16 x 2.000 LG	-	2
23	Armor Door Assembly, LH	111430-1	1
24	Rivnut, 3/8 - 16 (AVK)	ALS4-616-150	4
25	Support Striker Door	113327-1	1
26	Bolt, Countersunk, 3/8 - 16 x 2.000 LG	-	10
27	Bolt, Hex Head, GR8, 5/16 - 18 x 1.250 LG	-	9
28	Grommet	111453-1	1
29	Headed Press-Fit Bushing, 3/16 ID x 3/8 OD x 0.500 LG	-	1
30	Headed Press-Fit Bushing, 3/16 ID x 1/2 OD x 0.500 LG	-	1
31	Strap Assembly, Door	113386-1	1
32	Rivnut, 5/16-18 (AVK)	ALS4-518-150	2
33	Bolt, Hex Head, GR8, 5/16 - 18 x 0.750 LG	-	1
34	Hinge, Door	113313-1	1
35	Bracket, Hinge	113314-1	1
36	Bolt, Cap Head, Internal Hex, 5/16 - 18 x 1.000 LG	-	2
37	Bushing, Flanged	111411-1	2
38	Bolt, Cap Head, Internal Hex, 1/4 - 20 x 0.500	-	2
39	Pigtail, Wire (1-wire)	111438-3	1
40	Nut, Hex Head, Self-Locking, 7/16 - 14	-	5
41	Washer, 7/16 ID	-	9
42	Bolt, Hex Head, GR8, 7/16 - 14 x 4.000	-	4
43	Plate, Side-Aft, Panel	113316-1	4

The Side Armor Kit (RH), P/N 106703-10, consists of the following parts:

Item No.	Name	Part Number	Quantity
1	Washer, 3/16 x 0.063T	-	8
2	Washer, Lock, 3/16 ID	-	4
3	Bolt, Hex Head, GR8, 1/4 - 20 x 1.000 LG	-	4
4	Nut, Hex, Self-Locking, GRC, 1/4 - 20	-	2
5	Nut, Hex, Self-Locking, GRC, 3/8 - 16	-	25
6	Washer, 1/4 ID	-	10
7	Screw, Socket Head, 3/16 - 24 x 1.250 LG	-	4
8	Nut, Plain, 3/16 - 24	-	4
9	Bolt, Hex Head, GR8, 1/4 - 20 x 1.750 LG	-	4
10	Bolt, Hex Head, GR8, 5/16 - 18 x 1.500 LG	-	10
11	Bolt, Hex Head, GR8, 3/8 - 16 x 2.000 LG	-	4
12	Bolt, Hex Head, GR8, 3/8 - 16 x 1.500 LG	-	14
13	Washer, 5/16 ID	-	21
14	Washer, 3/8 ID	-	46
15	Decal	104301-1	1
16	Spacer, 0.4 Thick	113318-1	4
17	Cab Armor, Rear Panel (AL)	106729-5	1
18	Cab Armor, Front Panel (AL)	111432-3	1
19	Bolt, Hex Head, GR8, 3/8 - 16 x 3.000 LG	-	4
20	Cab Armor, Front Panel (ST)	111432-1	1
21	Cab Armor, Rear Panel (ST)	106729-3	1
22	Bolt, Hex, Head, GR8, 3/8 - 16 x 2.000 LG	-	2
23	Armor Door Assembly, RH	111430-2	1
24	Rivnut, 3/8 - 16 (AVK)	ALS4-616-150	4
25	Support Striker Door	113327-1	1
26	Bolt, Countersunk, 3/8 - 16 x 2.000 LG	-	10
27	Bolt, Hex Head, GR8, 5/16 - 18 x 1.250 LG	-	9
28	Grommet	111453-1	1
29	Headed Press-Fit Bushing, 3/16 ID x 3/8 OD x 0.500 LG	-	1
30	Headed Press-Fit Bushing, 3/16 ID x 1/2 OD x 0.500 LG	-	1
31	Strap Assembly, Door	113386-1	1
32	Rivnut, 5/16-18 (AVK)	ALS4-518-150	2
33	Bolt, Hex Head, GR8, 3/16 - 18 x 0.750 LG	-	1
34	Hinge, Door	113313-1	1
35	Bracket, Hinge	113314-1	1
36	Bolt, Cap Head, Internal Hex, 5/16 - 18 x 1.000 LG	-	2
37	Bushing, Flanged	111411-1	2
38	Bolt, Cap Head, Internal Hex, 1/4 - 20 x 0.500	-	2
39	Pigtail, Wire (1-wire)	111438-3	1
40	Nut, Hex Head, Self-Locking, 7/16 - 14	-	5
41	Washer, 7/16 ID	-	9
42	Bolt, Hex Head, GR8, 7/16 - 14 x 4.000	-	4
43	Plate, Side-Aft, Panel	113316-1	4

The Roof Armor Protection Kit, P/N 106704-3, consists of the following parts:

Item No.	Name	Part Number	Quantity
1	Bracket	106735-1	1
2	Bracket	106736-1	1
3	Stud Plate	106780-1	1
4	Stud Plate	106780-2	1
5	Shim, Roof Bracket	106796-1	1
6	Bolt, Hex Head, GR8, 1/4 - 20 x 1.000 LG	-	8
7	Bolt, Hex Head, GR8, 5/16 - 18 x 1.250 LG	-	14
8	Bolt, Hex Head, GR8, 3/8 - 16 x 1.500 LG	-	4
9	Nut, Hex, Self-Locking, GRC, 3/8 - 16	-	15
10	Washer, 5/16 ID	-	20
11	Washer, Lock, GR8, 5/16 ID	-	12
12	Washer, 3/8 ID	-	19
13	Armor Roof Assembly	106781-3	1
14	Handle, Grab	31-8-BLK	2
15	Spacer	8080R-S-5-35	2
16	Tap Bolt, Hex Head, GR8, 1/4 - 20 x 1.750 LG	-	5
17	Washer, 1/4 ID	-	21
18	Channel Roof Armor	113347-1	2
19	Nut, Hex, Self-Locking, 1/4 - 20	-	8
20	Bulb, Seal	103B375B3X3/16E	11 ft
21	Panel, Escape Hatch	113346-1	1
22	Plate, Stud Roof	106780-3	1
23	Nut, Eye	106795-1	2
24	Bracket, Escape Hatch	113357-1	4
25	Flexible Draw Latch, T-Handle	F7-51	4
26	Nut, Self-Locking, 5/16 - 18, GRC	-	4
27	Bolt, Cap Head, 3/16 - 24 x 0.750 LG	-	12
28	Washer, 0.19-in. ID	-	12
29	Tap Bolt, Hex Head, GR8, 5/16 - 18 x 1.750 LG	-	2
30	Tap Bolt, Hex Head, GR8, 1/4 - 20 x 1.500 LG	-	5

The Front Armor Protection Kit, P/N 106705-3, consists of the following parts:

Item No.	Name	Part Number	Quantity
1	Panel, Louvered Grille	111457-1	1
2	Panel, Louvered Grille	111457-2	2
3	Panel, Louvered Grille	111457-3	1
4	Panel, Louvered Grille	111457-4	1
5	Shim, Upper Brush Guard	106759-1	1
6	Bracket, Blackout Light	111459-1	1
7	Bolt, Hex Head, GR8, 3/8 - 16 x 1.500 LG	-	29
8	Bolt, Hex Head, GR8, 3/8 - 16 x 4.500 LG	-	4
9	Bolt, Hex Head, GR8, 3/8 - 16 x 1.250 LG	-	9
10	Nut, Hex, Self-Locking, GRC, 3/8 - 16	-	31
11	Washer, 3/8 ID	-	42
12	Brush Guard, Lower	111496-1	1
13	Brush Guard, Upper	111407-1	1
14	Bolt, Hex Head, GR8, 3/8 – 16 x 1.750 LG	-	6
15	Armor Panel, Brush Guard	111426-1	2
16	Cover, Upper Brush Guard	111437-1	1
17	Headlight Bracket	111418-1	1
18	Headlight Bracket	111418-2	1
19	Harness, Pigtail, 7-Wire	111438-4	2
20	Harness, Pigtail, 1-Wire	111438-3	1
21	Grommet	111453-1	2
22	Adapter, Marker Lamp Bracket	111442-1	2
23	Cover, Headlight	113379-1	2
24	Pan Head Sheet Metal Screw, No. 14 – 0.500 LG	-	6
25	Bolt, Hex Head, 1/4 – 20 x 1.000 LG	-	10
26	Washer, 1/4-in. ID	-	20
27	Nut, Hex, Self-Locking, 1/4 - 20	-	10

The Fastener Kit, Extra, P/N 111444-1, consists of the following parts:

NOTE

This Kit contains extra hardware to be used in place of lost or damaged hardware described in the previously-listed kits.

Item No.	Name	Part Number	Quantity
1	Bolt, Cap Head, Internal Hex, 3/16 - 24 x 0.750 LG	-	2
2	Bolt, Cap Head, Internal Hex, 1/4 - 20 x 1.250 LG	-	2
3	Bolt, Countersunk, 3/8 - 16 x 2.000 LG	-	4
4	Bolt, Hex Head, GR8, 1/4 - 20 x 1.000 LG	-	5
5	Tap Bolt, Hex Head, GR8, 1/4 - 20 x 1.250 LG	-	6
6	Tap Bolt, Hex Head, GR8, 1/4 - 20 x 1.500 LG	-	6
7	Tap Bolt, Hex Head, GR8, 1/4 - 20 x 1.750 LG	-	6
8	Bolt, Hex Head, GR8, 5/16 - 18 x 0.750 LG	-	2
9	Bolt, Hex Head, GR8, 5/16 - 18 x 1.250 LG	-	4
10	Tap Bolt, Hex Head, GR8, 3/8 - 16 x 1.250 LG	-	8
11	Tap Bolt, Hex Head, GR8, 3/8 - 16 x 1.500 LG	-	8
12	Tap Bolt, Hex Head, GR8, 3/8 - 16 x 2.000 LG	-	4
13	Tap Bolt, Hex Head, GR8, 3/8 - 16 x 2.500 LG	-	10
14	Bolt, Hex Head, GR8, 3/8 - 16 x 4.500 LG	-	3
15	Tap Bolt, Hex Head, GR8, 1/2 - 13 x 1.500 LG	-	2
16	Bolt, Hex Head, GR8, 0.750 - 10 x 4.500 LG	-	1
17	Nut, Hex, Self-Locking, GRC 3/16 - 24	-	6
18	Nut, Hex, Self-Locking, GRC 1/4 - 20	-	20
19	Nut, Hex, Self-Locking, GRC 5/16 - 18	-	4
20	Nut, Hex, Self-Locking, GRC 3/8 - 16	-	20
21	Nut, Hex, Self-Locking, GRC 0.750 - 10	-	2
22	Rivnut, 5/16 - 18 x 0.027 - 0.150 GRIP (AVK or Equivalent)	-	2
23	Rivnut, 3/8 - 16 x 0.027 - 0.150 GRIP (AVK or Equivalent)	-	3
24	Screw, Pan Head, 3/16 - 24 x 0.500 LG	-	2
25	Washer, Flat, 7/16 ID	-	2
26	Washer, Flat, GR8, Ø 3/16 ID	-	4
27	Set Screw, 10 - 32 x 0.310	-	2
28	Washer, Flat, Ø 1/4 ID	-	28
29	Washer, Flat, Ø 5/16 ID	-	8
30	Washer, Flat, Ø 3/8 ID	-	20
31	Washer, Flat, Ø 1/2 ID	-	2
32	Washer, Flat, Ø 0.750 ID	-	4
33	Bolt, Cap Head, Internal Hex, 3/16 - 24 x 1.250 LG	-	4
34	Nut Eye, 3/8 - 16	106795-1	1
35	Bolt, Hex Head, GR8, 3/4 - 10 x 2.500 LG	-	1
36	Bolt, Hex Head, GR8, 1/4 - 20 x 4.750 LG	-	2
37	Bolt, Hex Head, GR8, 5/16 - 18 x 1.500 LG	-	6
38	Bolt, Hex Head, GR8, 7/16 - 14 x 4.500 LG	-	2
39	Bolt, Hex Head, GR8, 3/8 - 16 x 4.750 LG	-	4
40	Bolt, Internal Hex, 1/4 - 20 x 0.500 LG	-	2
41	Nut, Hex, Self-Locking, 7/16 - 14	-	2

CREW PROTECTION ARMOR KIT ASSEMBLY PROCEDURES

WARNING

THE EDGES OF THE METAL ARMOR PANELS MAY BE SHARP. PROTECTIVE GLOVES SHOULD BE WORN BY THE INSTALLATION TEAM TO PREVENT PERSONAL INJURY.

THE HEMTT ARMOR COMPONENTS ARE HEAVY ITEMS THAT REQUIRE MORE THAN ONE PERSON AND / OR APPROPRIATE MATERIAL HANDLING EQUIPMENT (HOIST, FORKLIFT, ETC.) FOR HANDLING. THE WEIGHTS OF THE COMPONENTS BEING INSTALLED ARE SUFFICIENT TO CAUSE SERIOUS INJURY OR LOSS OF LIFE. CARE MUST BE TAKEN DURING INSTALLATION TO PREVENT INJURY.

HOISTING OPERATIONS HAVE INHERENT HAZARDS THAT CANNOT BE MECHANICALLY SAFE-GUARDED. PERSONNEL ARE REQUIRED TO WEAR HARD HATS AND SAFETY SHOES DURING INSTALLATION TO PREVENT PERSONAL INJURY.

CAUTION

During the application of paint or the re-application of paint, care must be taken to prevent covering up installation aid markings [**THIS SIDE OUT**, up arrows (↑), etc.]. These installation aid markings must be protected during paint application by using masking tape, paper, etc.

NOTE

Adjust the installed kit components, as necessary, prior to securing / tightening the attachment hardware.

5.1 INSTALL ARMOR PANELS

5.1.1 Install Armor Kit, Windshield, HEMTT, P/N 106701-4

CAUTION

The pressed studs used in various windshield mount components are subject to damage if proper precautions are not used. **DO NOT** hammer on the studs, as this may cause them to separate from the brackets. **DO NOT** use power impact wrenches to install locknuts on these parts; use light oil on the threads and hand tools to run the nuts down. **DO NOT** exceed Grade 5 torque values for these studs

Adjust the installed kit components, as necessary, prior to securing / tightening the attachment hardware.

NOTE

Torque fasteners to the values listed in Appendix A unless otherwise noted. The fasteners clamping the “J” brackets to the cab will require a torque wrench with a “crowsfoot” attachment. For windshield fastener brackets that cannot be accessed with a torque wrench, use the following guideline: Tighten the bolts to remove free play, mark the position, and turn the bolt clockwise an additional 1/2 to 3/4 of a turn.

- a) Locate and lay out all items listed in the parts list for the Windshield Armor Kit, P/N 106701-4, and the Windshield Fastener Kit, P/N 106701-904.
- b) Apply a small amount of Loctite to the 1/4 – 20 bolts and install them a few turns into the 0.250-in. threaded holes located in the Window Bracket Retainers (P/N 106734-1, -5-103, 106734-2, -6-103, and 106734-3, -7-103). The 1/4 – 20 bolts will be fully tightened once the brackets are placed on the vehicle.
- c) Place the Windshield Template (P/N 107405-1) on the vehicle, as shown in Figure 15. Place the Windshield Bracket (P/N 106734-3 or -7-103) on top of the template and against the window frame (see Figure 15). Once the bracket is located, tighten the upper and lower bolts so that the bracket clamps to the window frame of the vehicle. Do not tighten all of the bolts at this time, as adjustment may be required in the next steps. Using the same Template, install the other Windshield Bracket on the opposite side of the vehicle window frame. Remove the Template from the vehicle when complete.
- d) Place the Windshield Template (P/N 107405-3) on the vehicle, as shown in Figure 16. Place the Windshield Bracket (P/N 106734-1 or -5-103) against the Windshield Template, as shown in Figure 16. Tighten the bolts on both ends of the Windshield Bracket. Do not tighten all of the bolts at this time, as adjustment may be required in the next steps. Using the same Template, install the other Windshield Bracket on the opposite side of the window frame. Remove the Template from the vehicle when complete.

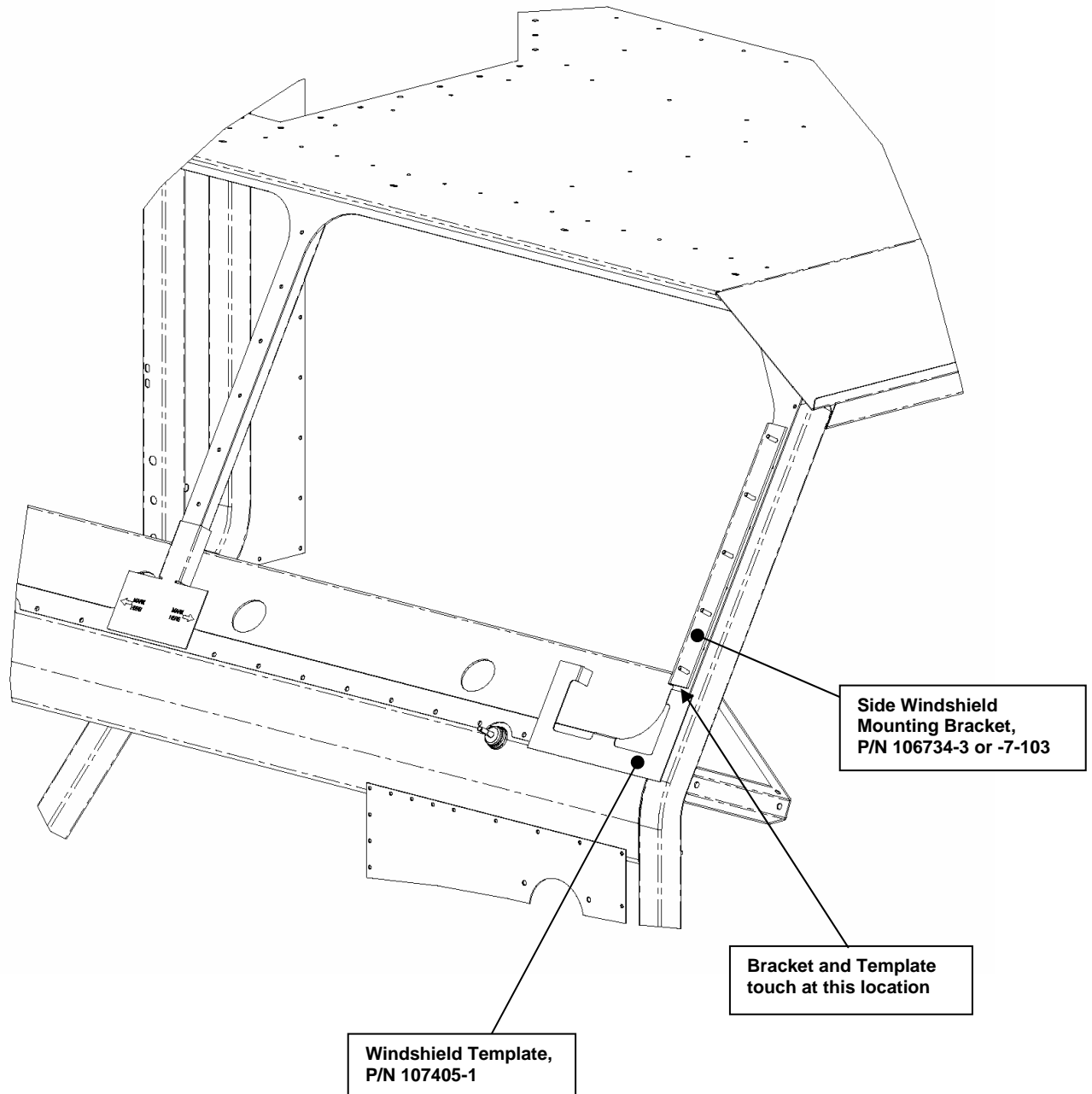

Figure 15. Windshield Bracket, Side Mounting.

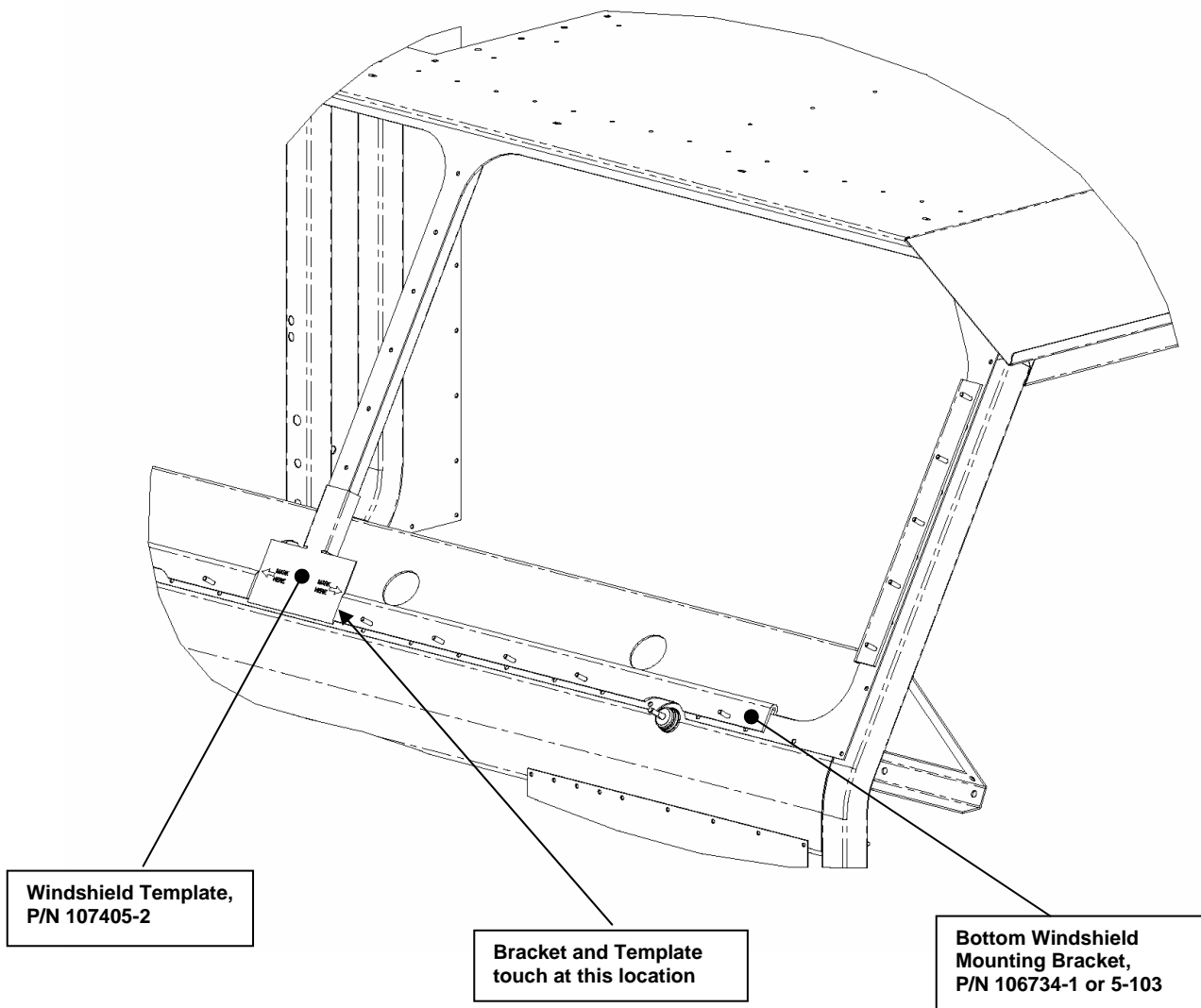

Figure 16. Windshield Bracket, Bottom Mounting.

- e) Attach the Top Windshield Brackets (P/N 106734-2 or -6-103) marked “**This Side Out**” to the **opposite** side of the Windshield Frame (P/N 106721-1-103) on the upper studs using twelve (12) 0.250-in. self-locking nuts and washers (see Figure 17). Verify that both brackets are parallel with the top edge of the windshield frame.
- f) Apply sealant (P/N 104302-1) to the windshield frame around the windshield stud plate mounting holes per Figure 17.
- g) Attach the Windshield Stud Plate, (P/N 106733-1-103) to the Windshield Frame using five (5) 0.250-in. self-locking screws and washers, as shown in Figure 18. Torque the nuts to 6 ft-lb.

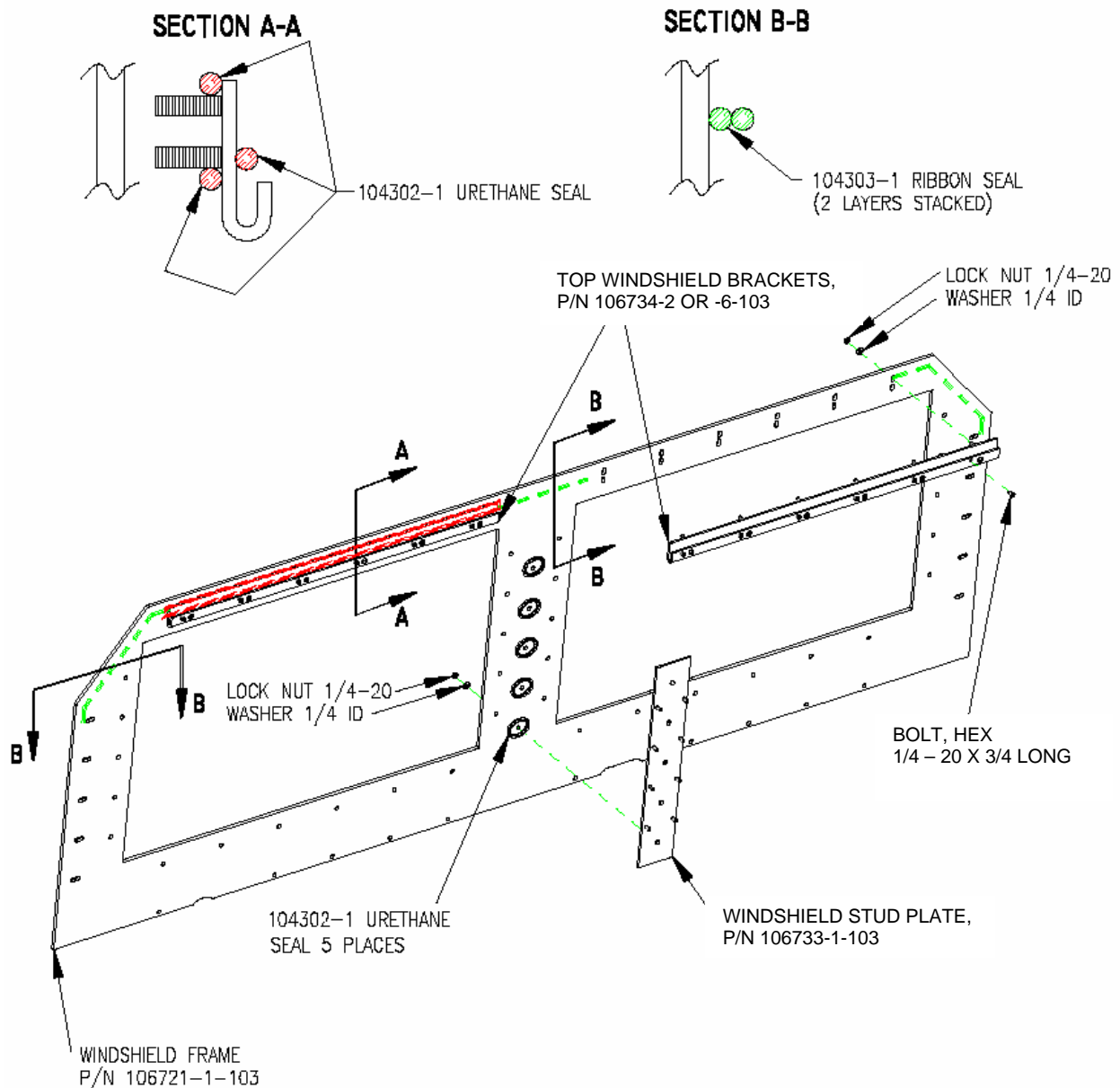

Figure 17. Windshield Frame pre-assembly.

- h) Pre-fit the Windshield Frame Assembly on the vehicle, as shown in Figure 18. Adjust the Side and Bottom Brackets as needed to line up the studs on the Windshield Frame. Use caution to avoid damage to the studs. DO NOT hammer the studs into position on the brackets. Remove the Windshield Frame Assembly and tighten the set screws in the Side and Bottom Windshield Brackets.



Figure 18. Position the Windshield Armor Frame into the cab windshield opening.

- i) To create an environmental seal between the Vehicle Cab and Windshield Frame apply the Urethane Sealant (P/N 104302-1) and the Ribbon Sealer (P/N 104303-1) as shown in Figure 19. If required, use additional sealant from the Front and Side Armor Kits.
- j) Attach the Windshield Frame Assembly to the vehicle as previously done in Step (g) using thirty-six (36) 0.250-in. self-locking nuts and thirty-six (36) 0.250-in. ID washers. Apply light oil to the studs prior to installation of the nuts. Torque to 6 ft-lb.
- k) From the inside of the cab, tighten the Set Screws on the Top Windshield Brackets (P/N 106734-2 or -6-103).
- l) Install the “L” Brackets (P/N 106746-1-103) using the fasteners, as shown in Figure 20. Apply light oil to the studs prior to installation of the nuts. Torque to 6 ft-lb.

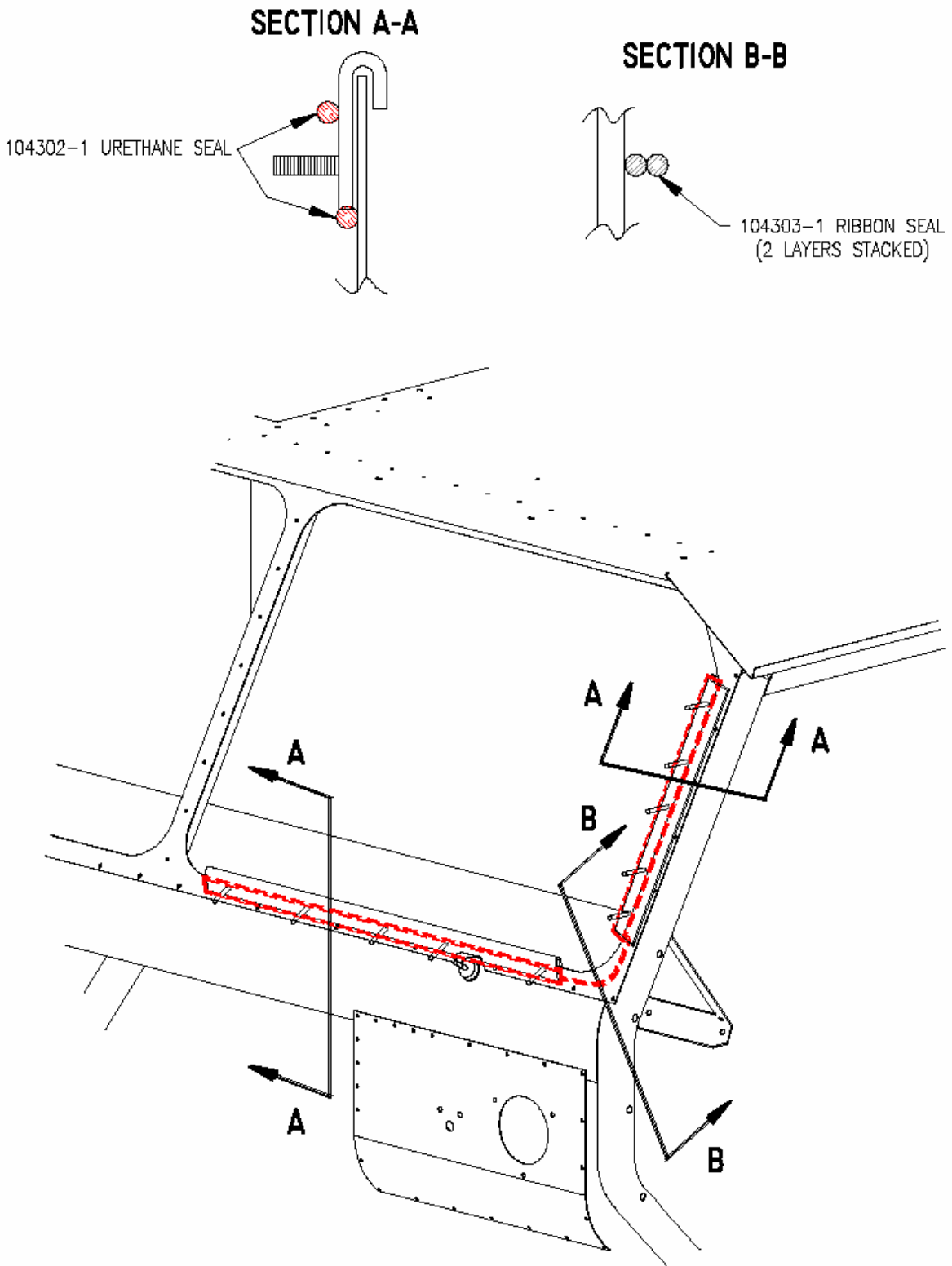

Figure 19. Urethane Sealant and Ribbon Sealer vehicle locations.

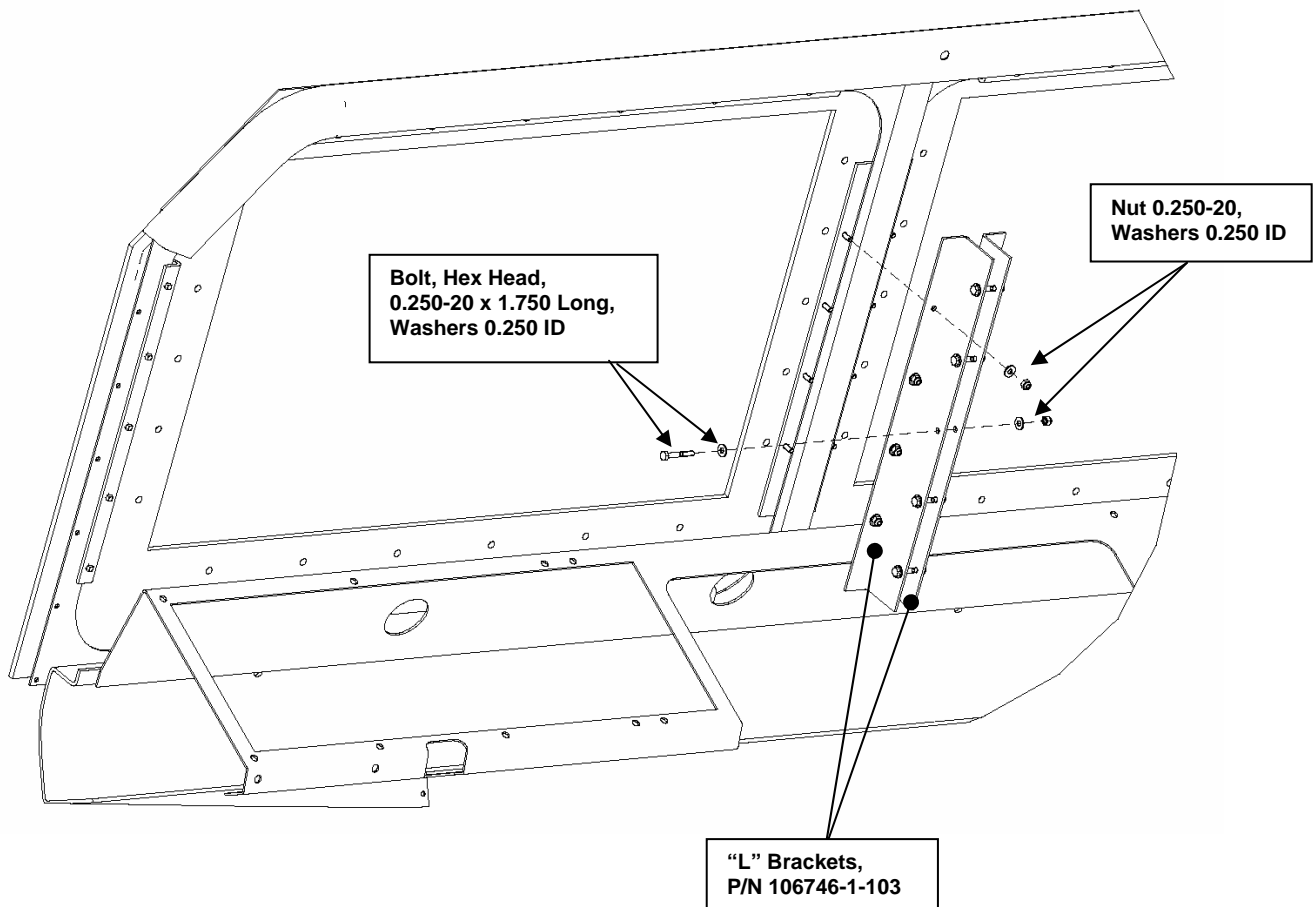

Figure 20. "L" Bracket Installation.

- m) Apply Urethane Sealant (P/N 104302-1) to the outside of the Windshield Frame (P/N 106721-1-103), as shown in Figure 21. This will provide a seal around the Windshield Armor (Glass) (P/N 113381-1) once it is installed.

WARNING

FOR PROPER THREAT PROTECTION, THE TRANSPARENT WINDSHIELD MUST BE CORRECTLY INSTALLED. ENSURE THAT THE STENCIL MARKING "INSIDE OF VEHICLE" IS LOCATED SO THAT THE IDENTIFIED SURFACE IS FACING THE INSIDE OF THE CAB. IMPROPERLY INSTALLED WINDSHIELD ARMOR WILL NOT PERFORM AS INTENDED AND MAY RESULT IN INJURY OR LOSS OF LIFE.

- n) Loosely attach the two lower Windshield Retaining Brackets (P/N 113383-1-103) using 0.250-in fasteners to the Windshield frame, see Figure 21. Set the Windshield Armor (P/N 113381-1) on the Retaining Brackets and over the openings of the Windshield Frame (P/N 106721-1). Complete the installation by securing the Windshield Armor in place, using the remaining Windshield Retaining Brackets (P/Ns 113383-1-103 and 113383-3-103), and tightening all the 0.250-in. fasteners, as shown in Figure 21.

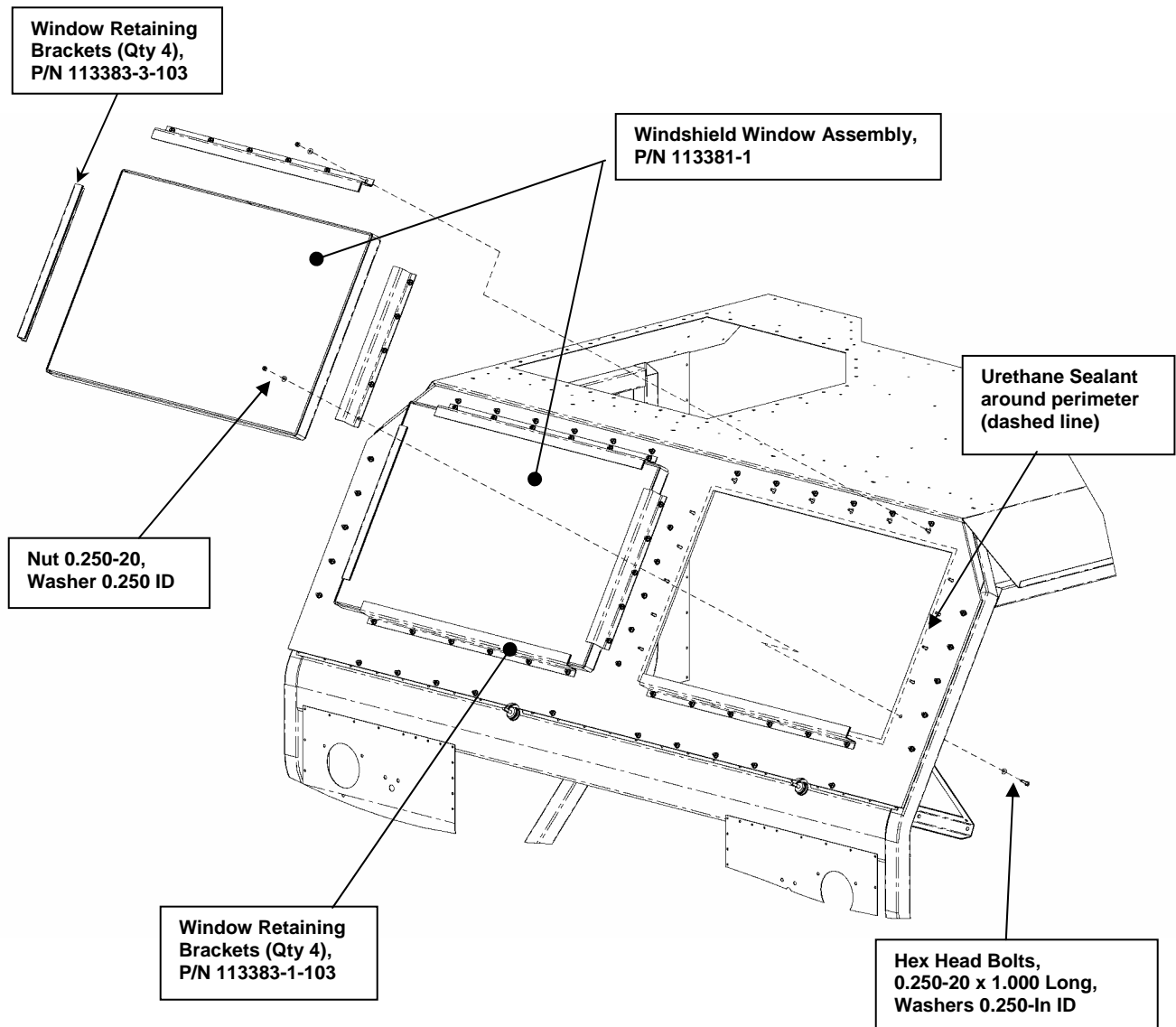

Figure 21. Armor Windshield installation.

- o) If this is the first time the Windshield Armor has been installed on a vehicle, apply the Cleaning Decal (P/N 104301-1) to the lower left hand corner of the Windshield Armor (see Figure 22) so that it does not obstruct the driver's / passenger's view. Remove the protective covers from the transparencies.
- p) Install the Wiper Extension (P/N 111408-3) by threading the part fully onto the wiper shaft and locking it in place using the set screw located on the side of the Wiper Extension (see Figure 22). Re-attach the Windshield Wiper and Hardware that was previously removed. Reconnect the wiper fluid hose to its nodule. Adjust the wiper as necessary for correct arm travel.
- q) It is recommended that leak check of the windshield be performed prior to returning the vehicle to service.

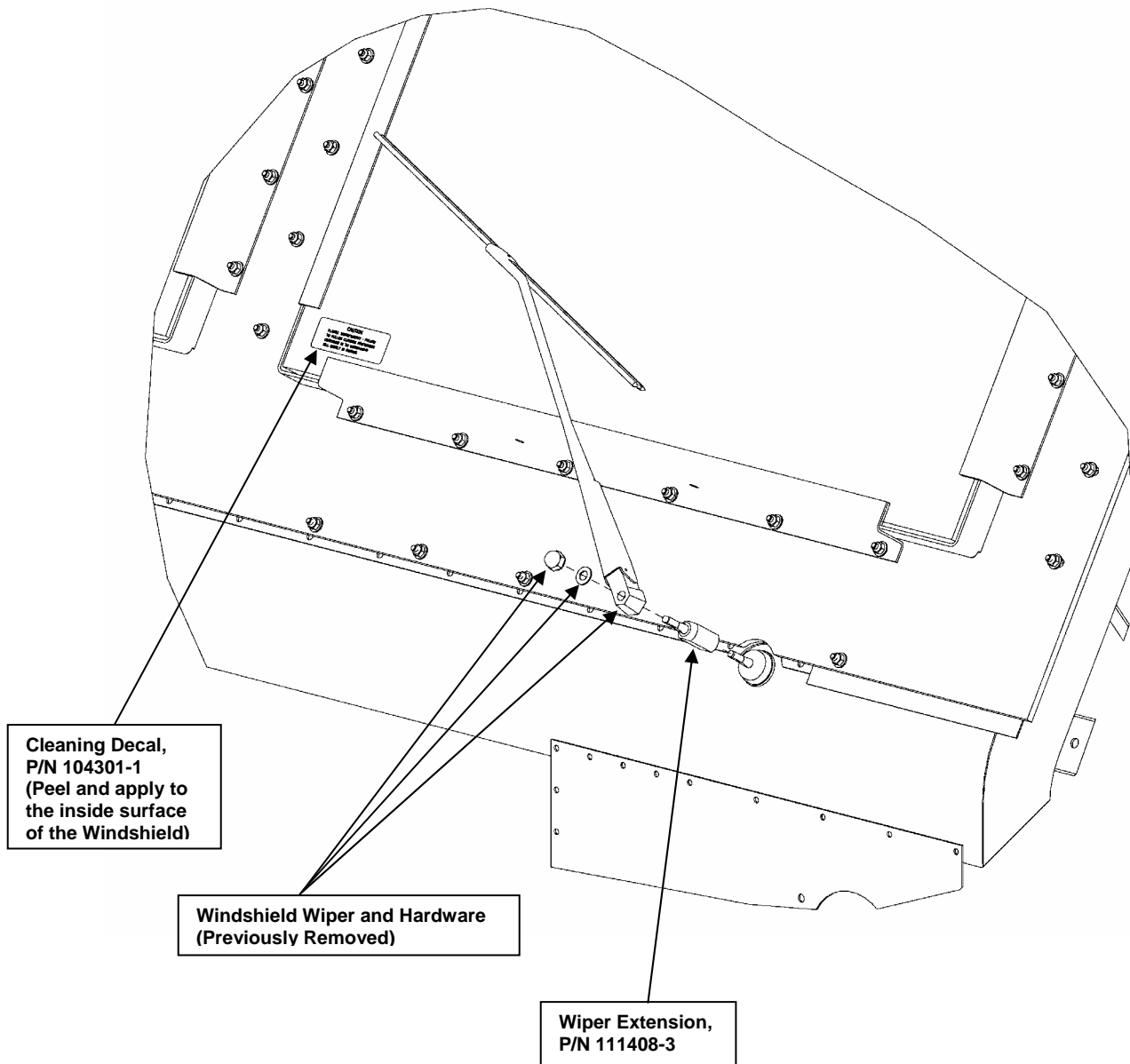

Figure 22. Windshield Wiper and Cleaning Decal installation.

5.1.2 Install Side Armor Protection Kit (RH), P/N 106703-10

- a. Install the Door Hinge (P/N 113313-1) and the Hinge Bracket (P/N 113314-1) onto the Front Cab Armor Panel (P/Ns 111432-1 and 111432-3 – the armor panel consists of two overlapping plates, with the thicker plate on the outside) using ten bolts (3/8 – 16 x 2.000 LG), ten washers (3/8 ID), and ten nuts (3/8 – 16) (See Figure 23).

NOTE

The Door Hinge knuckle must be at the top when the Front Cab Armor Panel is attached to the Bracket (See Figure 24).

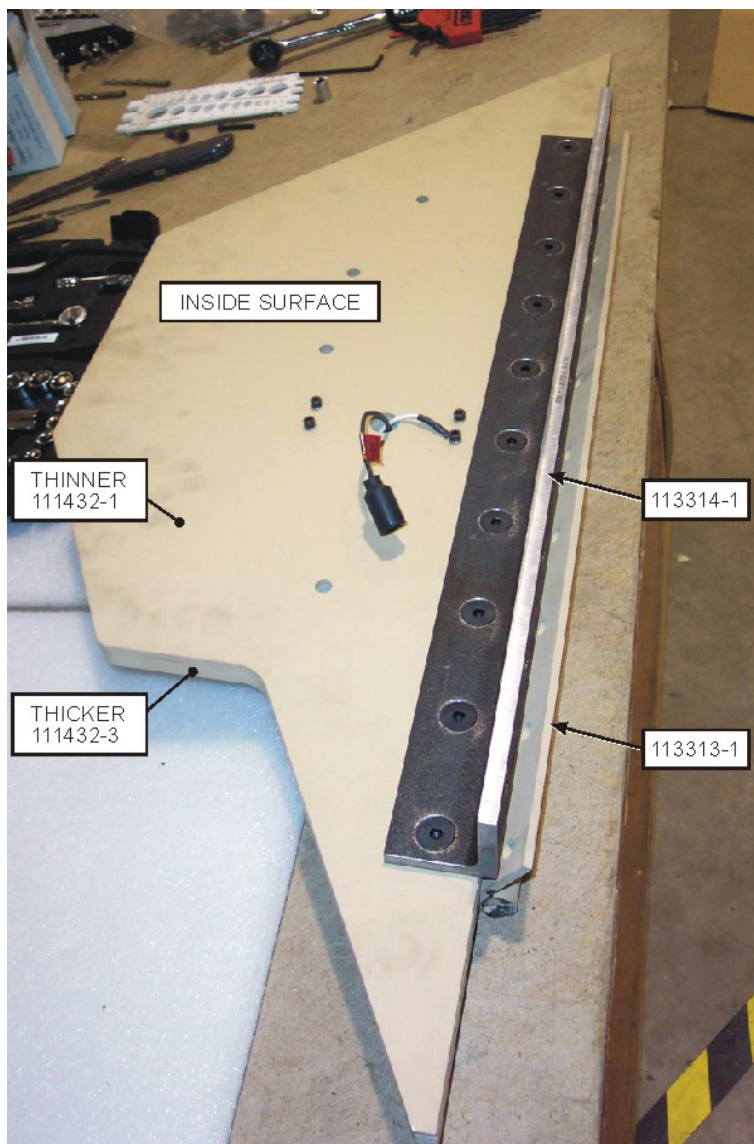

Figure 23. Installing the Door Hinge and Hinge Bracket on the Front Cab Armor Panel.

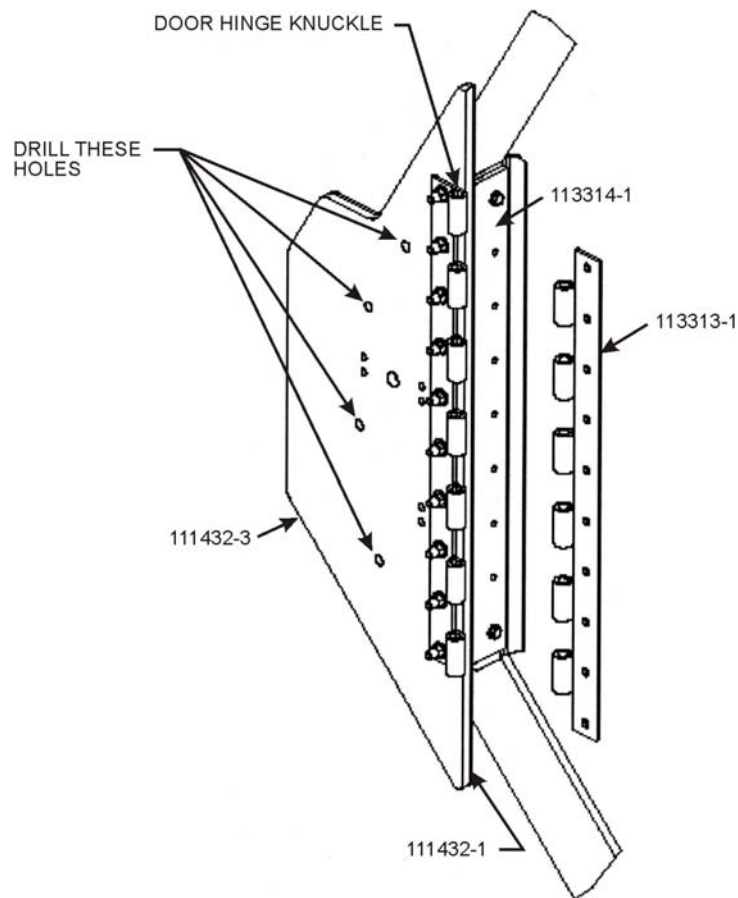

Figure 24. The correct Door Hinge orientation.

- b. Position the Front Side Cab Armor onto the side of the cab and secure the hinge bracket to the door pillar using four bolts (5/16 – 18 x 1.500 LG). Be sure it is tight, as this provides positions for other fasteners.
- c. Insert a drill bushing into the hole (X4) and match drill four 3/16-in. pilot holes.
- d. Remove the four mounting bolts securing the Front Side Cab Armor Plates to the Door Pillar and remove the Armor Plates from the vehicle.
- e. Using a drill and a 17/32-in. drill bit, drill through the four pilot holes.
- f. Install four Rivnuts [3/8 – 16 (AVK)] into the four holes drilled into the cab (Use the Rivnut Installation Tool, See Table 2).
- g. Install the existing clearance light gasket onto the amber clearance light, feed the clearance light wire through the appropriate hole in the Front Side Cab Armor Panel (P/Ns 111432-1 and 111432-3). Secure the amber clearance light onto the armor panel using four bolts (3/16 - 24 x 1.250 LG) and four nuts (3/16 - 24) (See Figure 25).

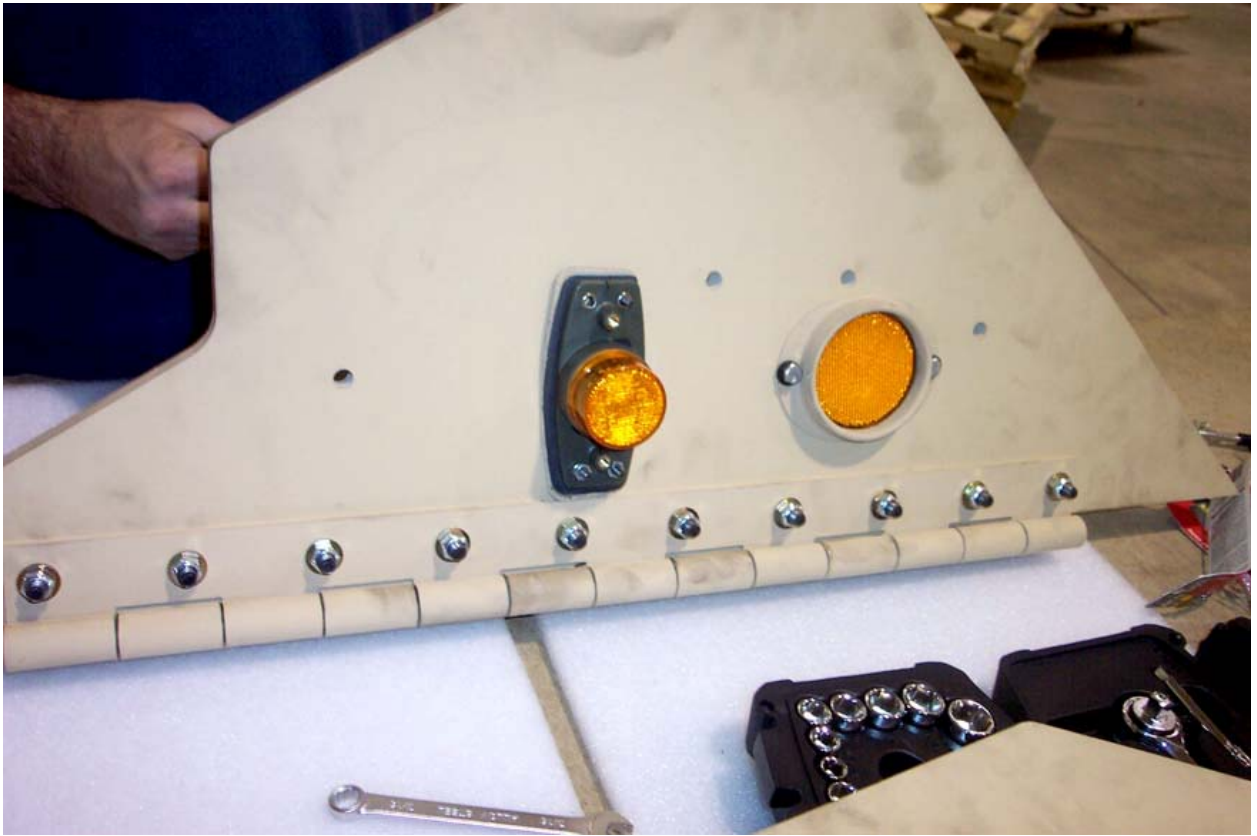

Figure 25. Install the amber clearance light and amber reflector onto the Front Side Cab Armor Panel.

- h. Attach the amber reflector to the Front Side Cab Armor Panel using two internal hex head bolts (1/4 - 20 x 0.500 LG) and two washers (1/4 ID).
- k. Feed the amber clearance light wire through the Slit Grommet (P/N 111453-1) (If the Grommet is not already slit, create the slit from the outer edge of the grommet into the center hole.) and press the Grommet into the hole in the cab side, and secure the Front Side Cab Armor Panels (P/Ns 111432-1 and 111432-3) to the cab using four bolts (3/8 - 16 x 2.000 LG), four flat washers (3/8 ID), and four spacers (P/N 113318-1) installed between the armor panels and the cab). Using a torque wrench, tighten each of the four bolts to 20 ft-lb.
- m. Connect the amber clearance light lead inside the cab using the Extension Pigtail (P/N 111438-3).
- n. Position the Front Side Cab Armor onto the side of the cab and secure the hinge to the door pillar using 9 bolts (5/16 – 18 x 1.500 LG).
- p. Secure the armor panel using four bolts (3/8 – 6 x 2.000 LG) into the previously installed rivnuts.
- r. Repeat Steps “a” through “p” for the Side Armor Kit (LH), P/N 106703-9.

5.1.3 Install the Front Armor Protection Kit, P/N 106705-3

- a. Install the LH and RH Seven-Wire Wiring Pigtail (P/N 111438-4) to extend the headlight and marker light wires (plug in).
- b. Insert the Seven-Wire Wiring Pigtail and the attached Grommet into the Headlight Cover (P/N 113379-1) on the LH and RH sides.
- c. Caulk the inside perimeter of the Headlight Covers with sealant (P/N 104302-1 of Kit P/N 106701-4).
- d. Attach the Headlight Covers (LH and RH) using three screws (No. 14 - 0.500 LG) for each cover (See Figure 26). Start the screws from inside the cab. The cover's holes are threaded for the No. 14 screw.



Figure 26. Install the Headlight Covers.

- e. Using a lift sling and material handling equipment (hoist, forklift, etc.), position the Lower Brush Guard (P/N 111406-) over the grille area of the front of the cab, and position the two armor panels (P/N 111426-1) on the Lower Brush Guard, and then attach the items to the cab using eight bolts (3/8 - 16 x 1.500 LG) and eight washers (3/8 ID); four bolts and washers are installed on each side of the Lower Brush Guard. Hand-tighten the eight bolts. Remove the material handling equipment and lift sling from the Lower Brush Guard (See Figure 27).
- f. Install the Upper Brush Guard Installation Guides (studs) (P/N 107430-1 of Kit P/N 106707-1) into the second threaded bolt hole from each outside end of the upper skid plate mounting frame. Hand-tighten the studs in place.

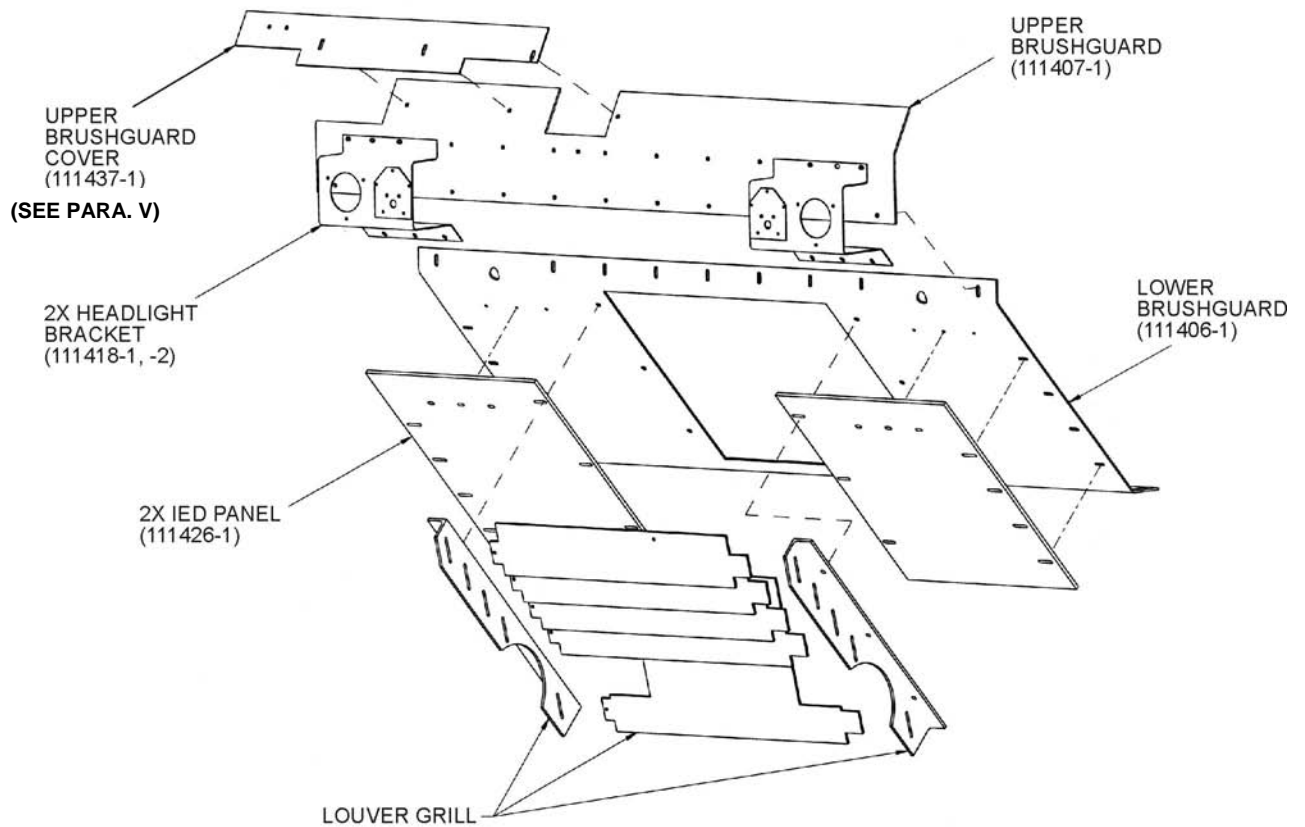

Figure 27. Front HEMTT Armor Kit locations.

- g. Install the Upper Brush Guard Shim (P/N 106759-1) over the Installation Guides.
- h. Feed the LH and RH Wiring Extension Harness through the hole in the Lower Brush Guard.
- k. Using a lift sling and material handling equipment (hoist, forklift, etc.), position the Upper Brush Guard (P/N 111407-1) onto the Installation Guides, over the installed Shim, and over the Lower Brush Guard with the “up” arrow (↑) facing the installer.

NOTE

The first and second bolt holes and the sixth and seventh bolt holes from the passenger-side end of the Upper Brush Guard use two bolts (3/8 - 16 x 4.500 LG), four washers (3/8 ID), and two nuts (3/8 - 16) for proper installation. Hand-tighten the bolts. (See Paragraph 5.1.6 if the vehicle is equipped with a gun ring mount.)

At this time, do not install bolts into the bolt holes over the headlight cutouts on the Upper Brush Guard.

- m. Apply Loctite 242 to five bolts (3/8 – 16 x 1.500 LG).
- n. Secure the Upper Brush Guard (P/N 111407-1) to the HEMTT using five bolts (3/8 – 16 x 1.500 LG) and washers (3/8 ID) (See Figure 28) on the upper portion of the Brush Guard, removing the two Installation Guides (P/N 107430-1) as the bolts are installed. Hand-tighten the bolts. Remove the material handling equipment and lift sling from the Upper Brush Guard.
- p. Adjust and position the Upper and Lower Brush Guards as necessary until the desired position is achieved, and then install 9 bolts (3/8 – 16 x 1.250 LG), 18 flat washers (3/8 ID), and 9 locknuts (3/8 – 16) through the Upper and Lower Brush Guard mating point, between the headlight cutouts. Hand-tighten the nuts.
- r. Verify the proper positioning of the Lower Brush Guard (P/N 111496-1) and the bolt holes at the bottom edge of the Lower Brush Guard under the cab door.
- s. Torque the eight bolts (3/8 – 16 x 1.500 LG), on the Lower Brush Guard sides to 23 ft-lb.
- t. Torque the five bolts (3/8 – 16 x 1.500 LG), on the uppermost portion of the Upper Brush Guard to 23 ft-lb.
- u. Torque the nine locknuts and bolts (3/8 – 16 x 1.500 LG), in the bolt line even with the headlight cutouts, to 35 ft-lb.
- v. Install the Upper Brush Guard Cover (P/N 111437-1) using three bolts (3/8 – 16 x 1.500 LG), six washers (3/8 ID), and three locknuts (3/8 – 16). (Note: The notched portion is up when the vehicle does not have a gun ring mount.)

5.1.4 Install the Headlights

- a. In order to install the Headlight Assemblies, it is necessary to identify which type of Marker Light is used on the vehicle. Before being removed, the Marker Light was located just inboard of the Headlight. Inspect the Marker Light and determine whether an incandescent bulb (i.e., a common lamp bulb) is used inside the light. If an incandescent bulb is **NOT** found, install the Headlight Assemblies using Steps b, c, e, and f, as the Adapter, P/N 111442-1, is not required. If an incandescent bulb **IS** found, install using Steps b through f.
- b. Install the LH Headlight Bracket (P/N 111418-1) (See Figure 28) using two bolts (3/8 – 16 x 1.500 LG) and four washers (3/8 ID) in the top holes. Then, install three bolts (3/8 – 16 x 1.500 LG), six washers (3/8 ID), and three locknuts (3/8 – 16) in the bottom holes of the Headlight Bracket.



Figure 28. Left-hand Headlight Bracket Installed.

- c. Install the RH headlight bracket (P/N 111418-2) using three bolts (3/8 – 16 x 1.500 LG), six washers (3/8 ID), and three locknuts (3/8 – 16) (See Figure 28). Hand-tighten the locknuts. For the bottom holes, use the three bolts (3/8 – 16 x 1.500 LG), six washers (3/8 ID), and three locknuts (3/8 – 16).

- d. Install the LH and RH Marker Light Adapter (P/N 111442-1) to the rear of the Headlight Brackets using five bolts (1/4 – 20 x 1.000 LG) and five washers (1/4 ID) for each bracket.
- e. Plug the LH and RH headlights and marker lights into the Wiring Extension Harness, matching the wire colors and cable numbers.
- f. Re-install the LH and RH headlights and marker lights in the LH and RH mounting brackets using the previously saved bolts/washers/nuts

5.1.5 Install the Armored Louvered Grille

NOTE

The Louvered Grille Brackets are marked “THIS SIDE TOWARD RADIATOR” and “THIS END UP” for proper installation. Verify that the Louvered Grille Brackets are oriented correctly prior to final assembly.

The installed Louvered Grille Brackets should be positioned to the extreme driver’s-side and passenger-side stops prior to securing the attachment hardware.

- a. Install the driver’s-side Louvered Grille Bracket (P/N 106772-1 and the passenger-side Louvered Grille Brackets (P/N 106772-2) to the Lower Brush Guard (P/N 111406-1) and Armor Panels (P/N 111426-1) using 6 bolts (3/8 – 16 x 1.750 LG), 12 flat washers (3/8 ID), and 6 locknuts (3/8– 16) (See Figure 28). Tighten the locknuts to 35 ft-lb.

NOTE

The Louvered Grille Panel tabs have arrows (↑) marked on the driver’s side for proper installation. Verify that the Louvered Grille panels are oriented correctly with the end that has the bolt hole located on the passenger side of the vehicle.

When installing the Louvered Grille Panels, insert the tabbed end without the bolt hole into the driver’s-side Louvered Grille Bracket first and then insert the tab with the bolt hole into the passenger-side Louvered Grille Bracket. When installed properly, the arrows on the Louvered Grille Panel tabs should be vertically aligned.

- b. Install the bottom Louvered Grille Panel (P/N 111457-4) into the bottom slots of the Louvered Grille Brackets.
- c. Install the second-to-last Louvered Grille Panel (P/N 111457-3) into the second-to-last bottom slots of the Louvered Grille Brackets.
- d. Install the third Louvered Grille Panel (P/N 111457-2) into the third-from-the-top slots of the Louvered Grille Brackets.
- e. Install the second Louvered Grille Panel (P/N 111457-2) into the second-from-the-top slots of the Louvered Grille Brackets.

- f. Install the top Louvered Grille Panel (P/N 111457-1) into the top slots of the Louvered Grille Brackets.
- g. Secure the Louvered Grille Panels to the Louvered Grille Brackets by installing five bolts (3/8 – 16 x 1.500 LG), ten flat washers (3/8 ID), and five locknuts (3/8 – 16) through the ends of the passenger-side Louvered Grille Panels. Tighten the locknuts to 35 ft-lb.

5.1.6 Install the Rear Cab Armor Panels – Kit P/N 106702-3

NOTE

See Figure 29a and Paragraph “p” prior to installation.

- a. Remove the nut from the Harness Bracket (See Figure 29) and move the spacer to the rear of the Bracket to clear the mounting of the Rear Cab Armor Panel Bracket.
- b. Replace the nut and secure the Harness Bracket.



Figure 29. Move the Harness Bracket to the inside for increased clearance for the Rear Cab Armor Panel Bracket.

- c. Install four Mounting Armor Brackets (P/N 106734) onto the Rear Cab Armor Panel (P/N 106724-3) (See Figure 30) using 12 washers (3/8 ID), 12 washers (1/4 ID), and 12 locknuts (1/4 – 20). Tighten the locknuts finger tight.

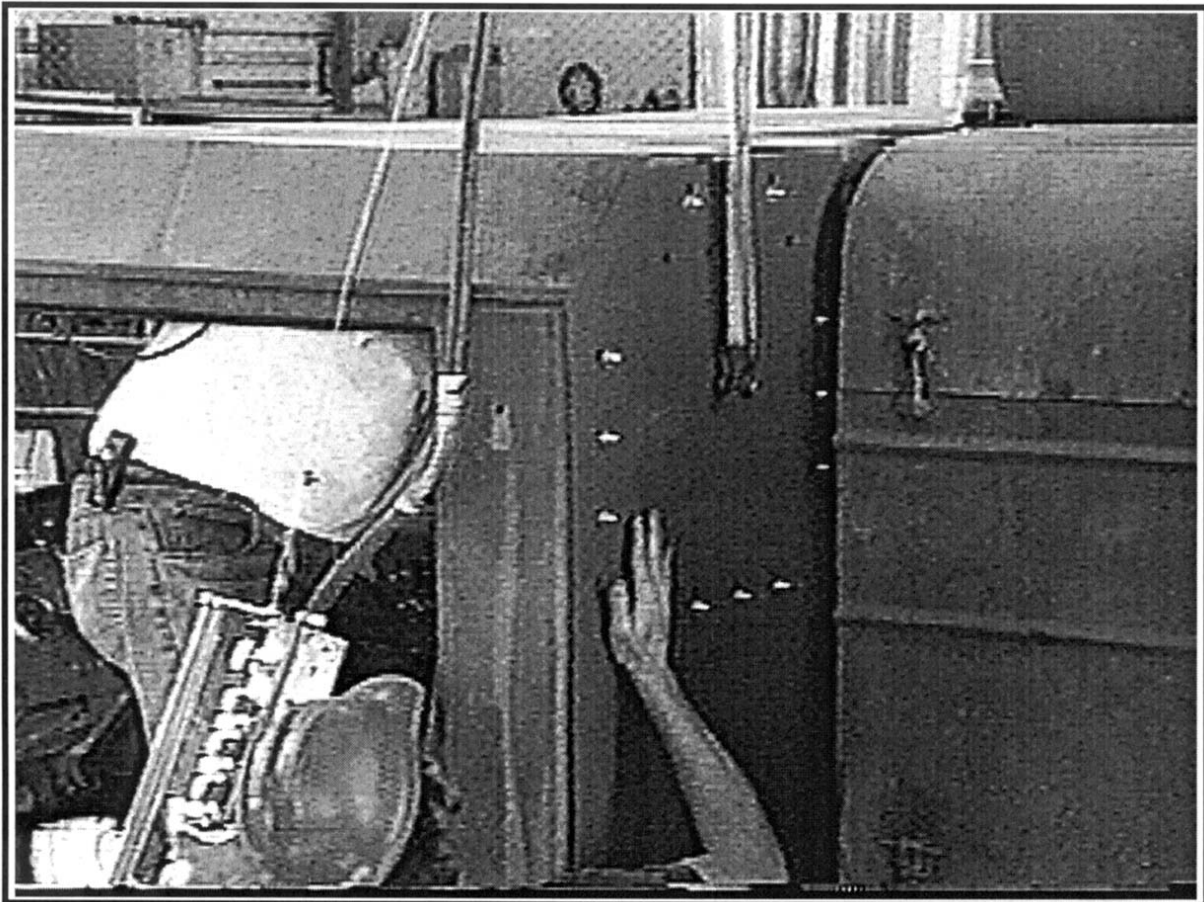

Figure 30. Install Mounting Armor Brackets to the driver's-side rear cab armor panel.

- d. Apply Loctite 242 to 12 bolts (1/4 - 20 x 0.750 LG) and install them two turns into the four Mounting Armor Brackets (P/N 106734-4) previously installed on the driver's-side rear cab armor panel.
- d1. Using a bolt (3/8 - 16 x 1.250), washer (3/8 ID), and the nut eye (P/N 106795), secure the nut eye in the 1/2-in. hole in the center of the panel with the nut eye outboard. Once the panel is secured, remove the nut eye and replace it with a washer (3/8 ID) and lock nut (3/8 - 16) from the Extra Fastener Kit. Torque to 35 ft-lb. The nut eye will be used to position the other rear cab armor panel.
- e. Using a lift sling and material handling equipment (hoist, forklift, etc.) position the driver's-side Rear Cab Armor Panel (P/N 106724-3) onto the outside rear of the cab, with the arrow (↑) pointing up and facing the installer, and slide the Mounting Armor Brackets over the rear cab window opening edges (See Figure 31).

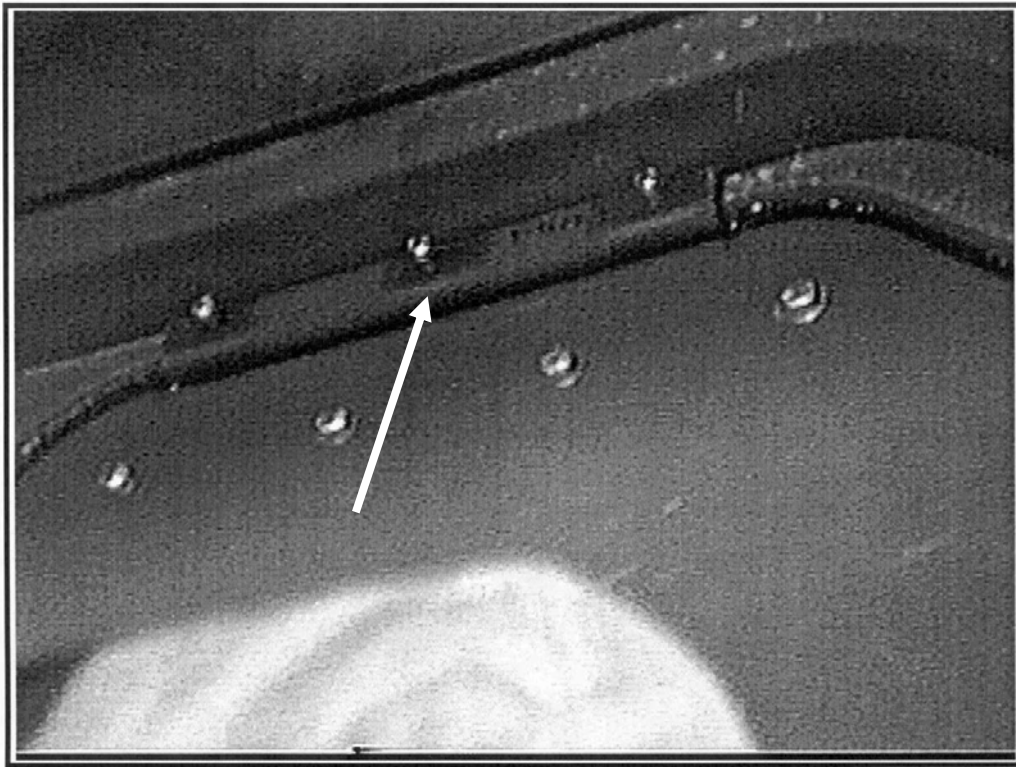

Figure 31. Slide the Mounting Armor Brackets over the rear cab window opening edges.

- f. Adjust the driver's-side Mounting Armor Brackets, as necessary, and tighten the 12 bolts (1/4 – 20 x 0.750 LG) to secure the Mounting Armor Brackets to the cab. Torque the bolts to 9 ft-lb.
- g. Tighten the 12 locknuts (1/4 – 20) that secure the driver's-side Rear Cab Armor Panel to the Mounting Armor Brackets. Torque the locknuts to 9 ft-lb.
- h. Use urethane caulking (P/N 104302-1) to caulk the gap between the driver's-side Rear Cab Armor Panel and the rear cab window opening.
- k. Remove the material handling equipment and lift sling from the driver's-side Rear Cab Armor Panel.
- m. Drill a 1/4-in. Ø hole two places (see Figure 29a) (centered) through the 2.000 and 2.250 Ø holes in the armor panel into the cab.
- n. Install bolt (1/4 – 20 x 1.250), armored washer (P/N 111403-1), washer (1/4-in. ID), and self-locking nut (1/4 – 20), with the fender washer on the inside of the cab, in two places (see Figure 29a). If the sound-damping material is in the way, remove it from around the hole.
- o. Repeat Steps “a” through “n” for the passenger-side Rear Cab Armor Panel (P/N 106724-4), except only one armored washer installation is required (see Figure 29a).

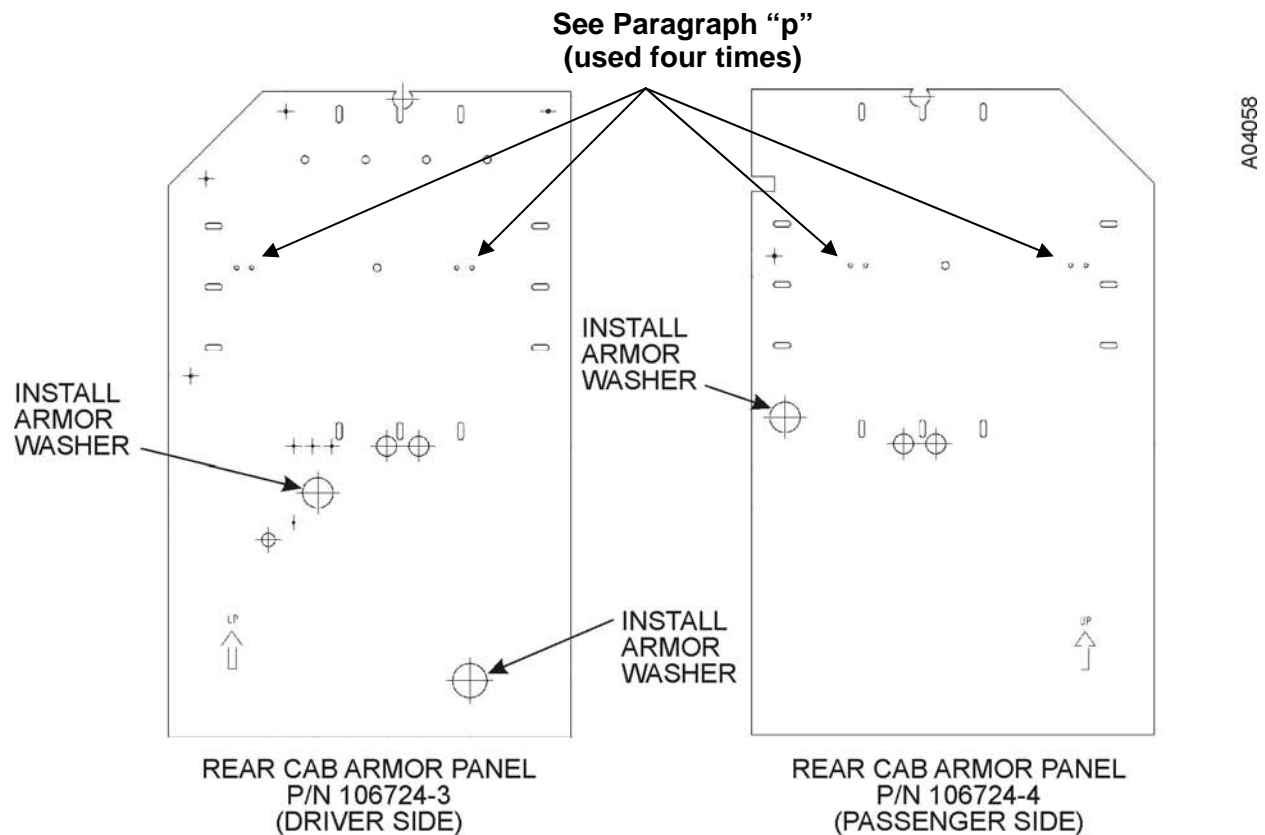

Figure 29a. Armored washer locations.

- p. Prior to installation, insert four bolts (1/4 – 20 x 1.000), eight washers (1/4 ID), and four nuts (1/4 -20) through the four optional energy-absorbing seat mounting holes on each armor panel (see Figure 29a for locations). Ensure that the nut is on the outboard side.

5.1.7 Install the LH and RH Armored Door Assembly – Side Armor Kit P/N 106703-9 (Driver's-side) and P/N 106703-10 (Passenger-side)

- a. Install a lift strap through the lifting eyes on top of the Armored Door Assembly [P/N 111430-1 (Driver's-side) / 111430-2 (Passenger-side)].
- b. Using the lift strap and material handling equipment (hoist, forklift, etc.), position the Armored Door Assembly into the cab door opening and install the Armored Door Assembly to the cab hinge (See Figure 32) using 10 bolts (3/8 – 16 x 1.500 LG), 20 washers (3/8 ID) and 10 locknuts (3/8 – 16). Hand-tighten the bolts to secure the door to the cab for adjustment.



Figure 32. Install the Armored Door Assembly to the cab (driver's-side door shown).

- c. Check the Armored-Door-Assembly-to-cab fit and alignment, and adjust the door and/or latch pin as necessary until the alignment is correct.

NOTE

If necessary, washers or shims may be placed between the door latch assembly and the door to adjust the latch inboard if the latch is not completely engaging the striker. Shim adjustment should not exceed 3/16 in.

- d. Tighten the ten bolts (3/8 – 16 x 1.500 LG) to secure the Armored Door Assembly in place. Torque the bolts to 18 ft-lb.

NOTE

The protective paper that is attached to the transparent Window Armor Panels is removed during the first installation. Subsequent Window Armor Panel installation will not have this protective paper, and the cleaning decal will already be installed on the Window Armor Panel. Use care when handling the Window Armor Panels to avoid breaking / chipping / scratching them.

- e. Remove the protective paper from the transparent Window Armor Panel, if necessary.
- f. If necessary, apply the Cleaning Decal (P/N 104301-1) onto the transparent Window Armor Panel in a location that minimizes the vision obstruction to the vehicle operator.
- g. Apply Loctite to one bolt (5/16 – 18 x 0.750 LG).
- h. Fasten the new Strap Assembly (P/N 113386-1) to the Armored Door using one bolt (5/16 – 18 x 0.750 LG) and one washer (5/16 ID).
- k. Locate the Strap Assembly attachment point on the top of the door frame at a point 5.5 in. from the corner (See Figure 33).
- m. Mark the location of the attachment point on the top of the door frame using a center punch and a hammer.
- n. Using a drill and a 3/16-in. drill bit, drill a pilot hole through both walls of the door pillar in the position marked.
- p. Using a drill and a 17/32-in. drill bit, drill through both pilot holes in the door pillar.
- r. Install the Strap Assembly to the door pillar using one bolt (3/8 – 16 x 3.000 LG), two washers (3/8 ID), and two flange bushings (P/N 111411-1), one on each side of the tube, and one locknut (3/8 – 16) torqued to 10 ft-lb (See Figure 33 and 34).
- s. Attach the Striker Bracket and Striker to the door frame (the hardware is attached to the Door Assembly), using the existing striker hole (see Figure 33a) and a new lock nut (7/16 – 14) from the Extra Hardware Kit.
- t. Locate the Striker Support (P/N 113327-1) firmly under and against the Striker Bracket and clamp it in place on the cab “B” Pillar with a “C” clamp.
- u. Insert two 3/8-in. OD drill bushings in two holes and, using a drill and a 3/16-in. drill bit, drill two pilot holes in the door pillar in the positions marked. Remove the Striker Support.
- v. Using a drill and a 17/32-in. drill bit, drill through the two pilot holes in the door pillar.
- w. Install two Rivnuts [5/16 - 18 (AVK)] using the Rivnut Installation Tool (See Table 2).

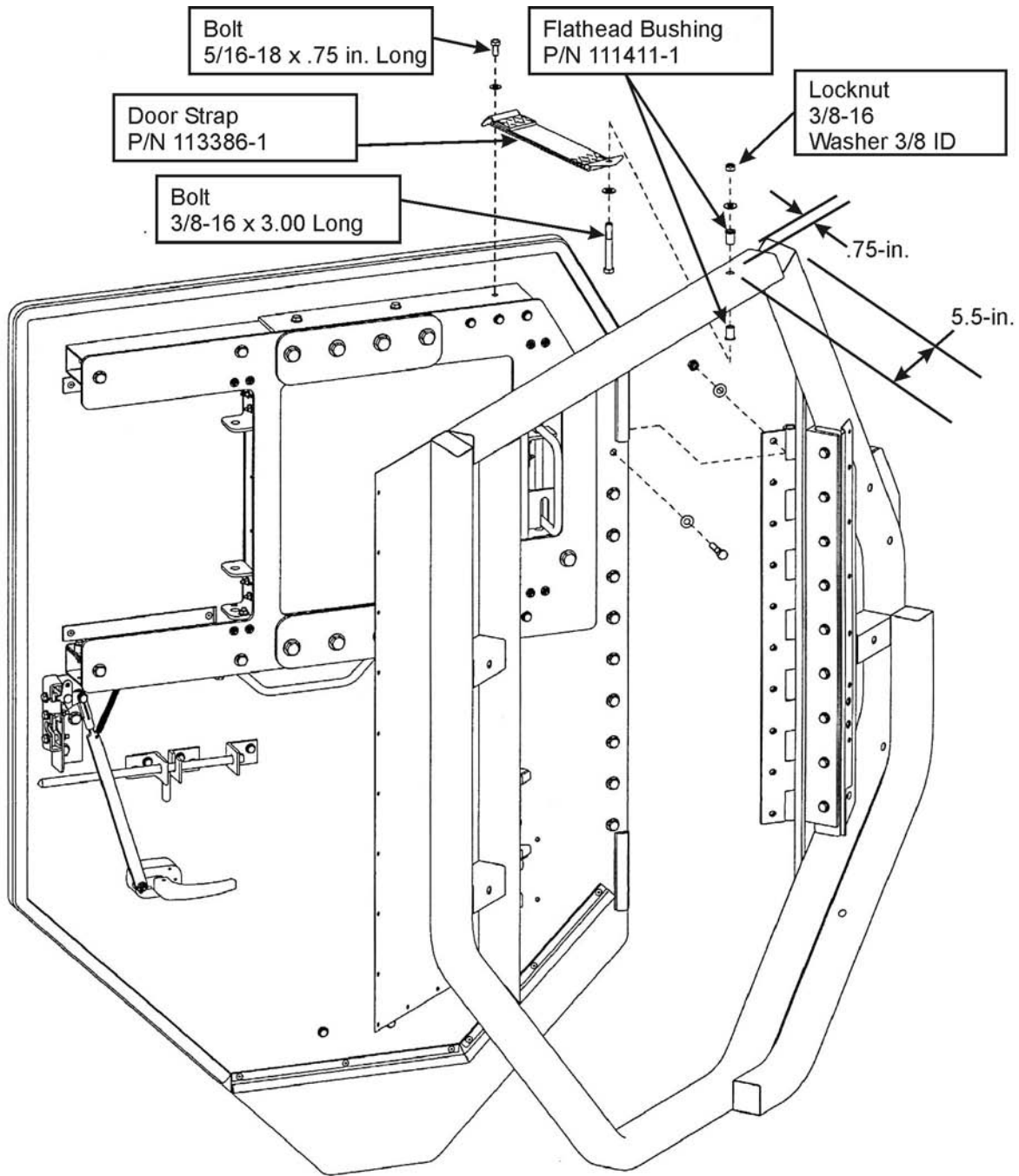

A050008

Figure 33. Locate the Strap Assembly attachment point and Install the Door Striker.

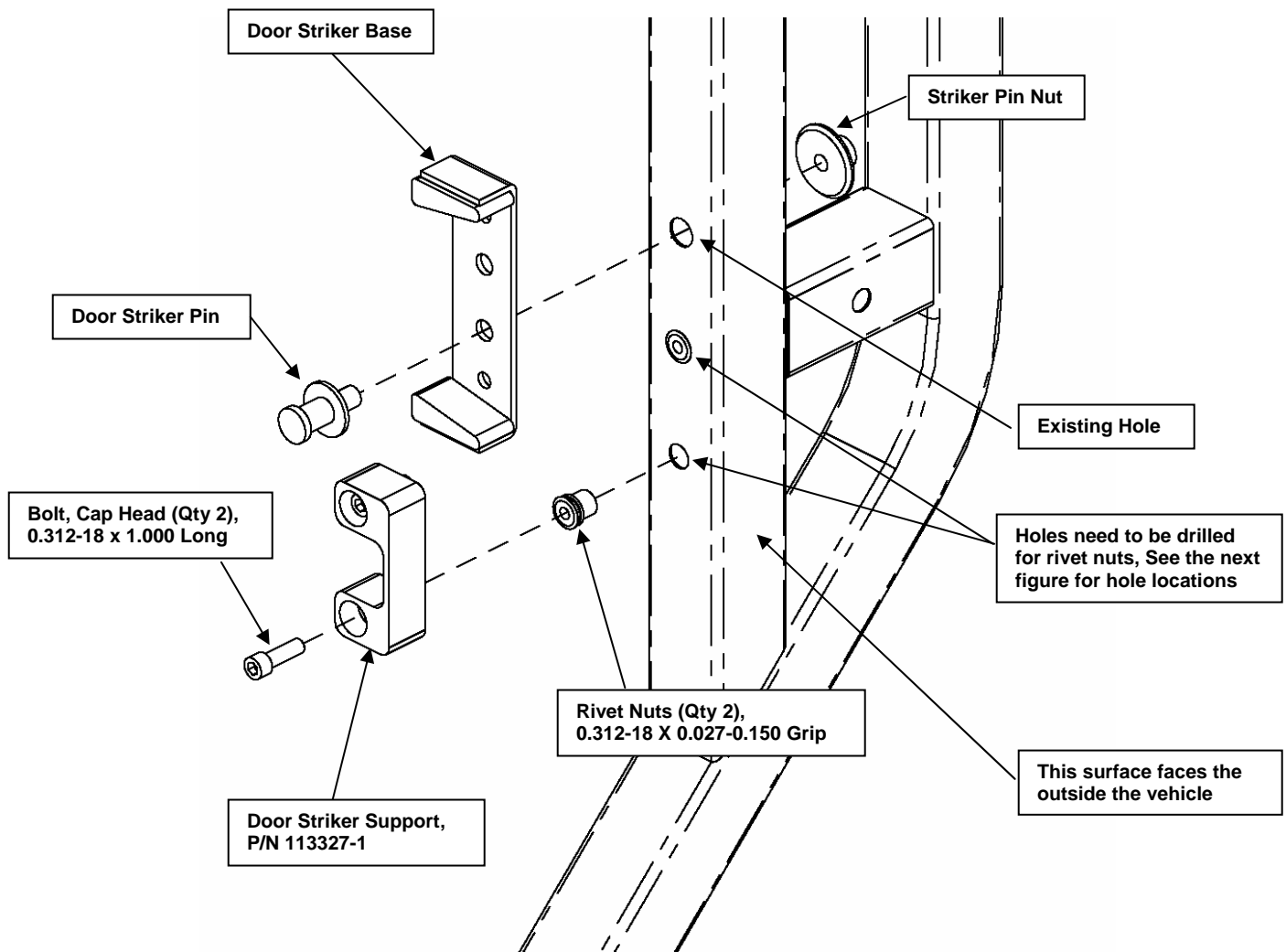

Figure 33a. Locate and install the Door Striker.

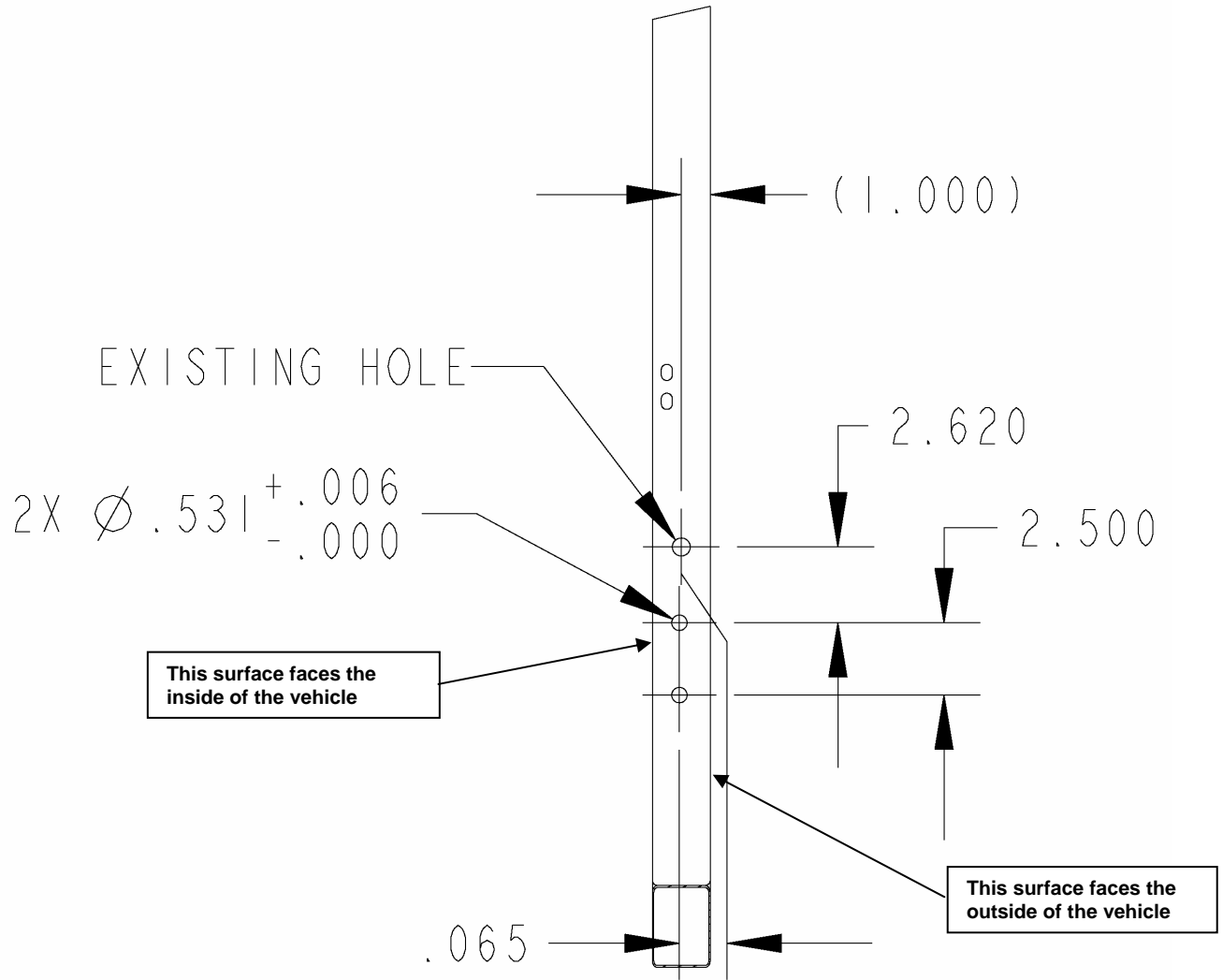

Figure 33b. Door Striker Support Hole locations.



Figure 34. Install the new Attachment Strap to the Armored Door Assembly.

- x. Install the Striker Support (P/N 113327-1) using two cap head bolts (5/16 – 18 x 1.000 LG) (See Figure 33a). (As an alternate use a 5/16 – 18 x 1.250 LG bolt.)
- y. Adjust door latch linkage and/or the door rotary latch up / down and in / out as required (using washers in the extra fasteners kit (P/N 111444-1).
- z. Repeat Steps “a” through “y” for the remaining Armored Door Assembly installation.

5.1.8 Install the LH and RH Rear Side Cab Armor Panel, Kit P/N 106703-9 (LH) and P/N 106703-10 (RH)

NOTE

Torque fasteners to 8 ft-lb.

- a. Install the Rear Cab Armor Panels to mark the positions of the bolts that secure the Panels to the cab.
 - 1. Position the Rear Side Cab Armor Panels (for the LH Panels, use P/Ns 106729-3 and 106729-5 from Kit P/N 106703-9; for the RH panels, use P/Ns 106729-3, and 106729-5 from Kit P/N 106703-10) onto the rear side of the cab (See Figure 35 and 35a). The thicker panel is placed to the outside.

A050005

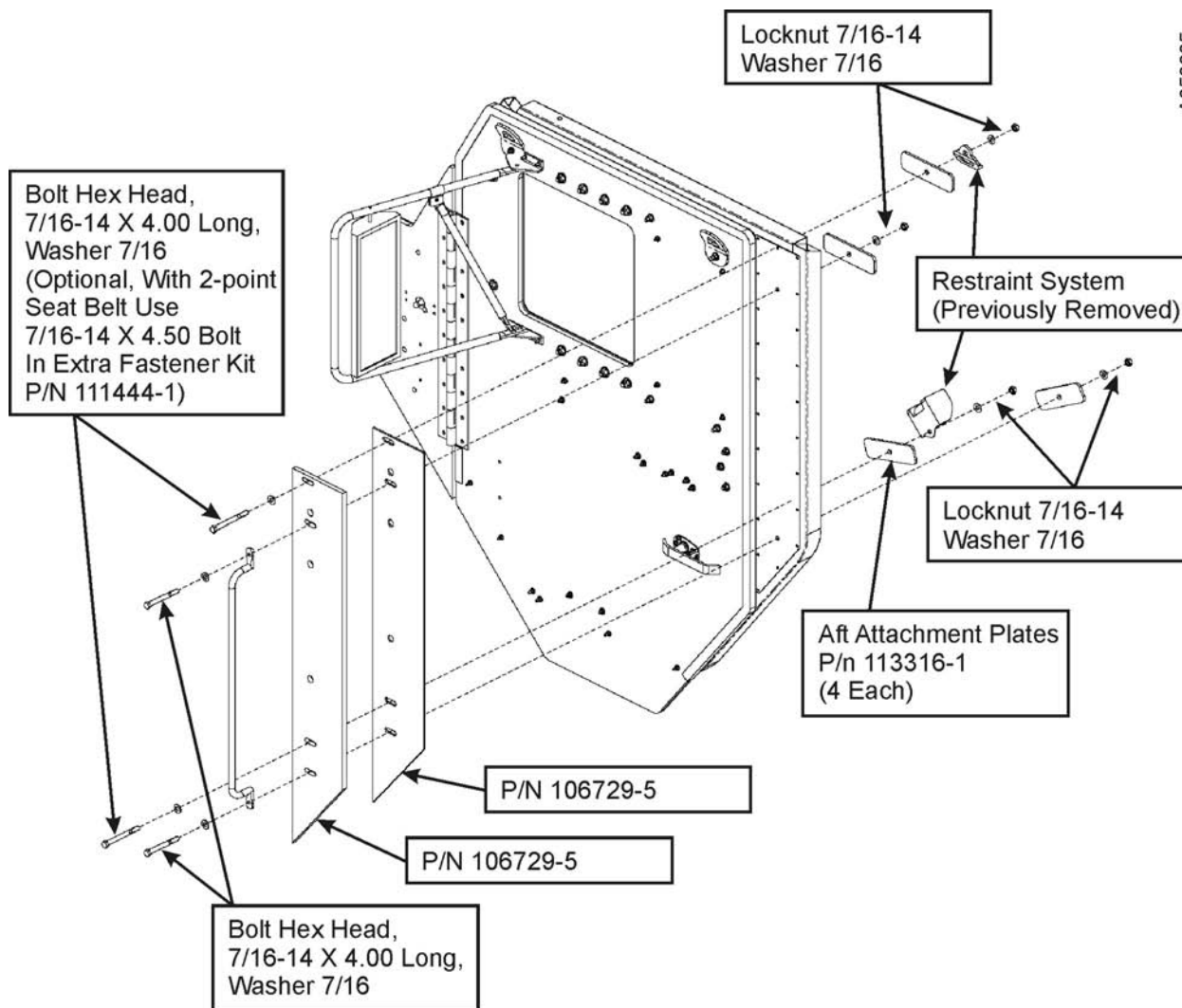

Figure 35. Install the Rear Side Cab Armor Panel.



Figure 35a. The Rear Side Cab Armor Panel installed.

2. Position the Cab Entry Hand Hold on top of the Rear Side Cab Armor Panels and secure it (and the Panels) in place using two bolts (7/16 - 14 x 4.000 LG), four flat washers (7/16 ID), and two locknuts (7/16 - 14). Do not tighten the bolts and nuts at this time.

NOTE

The gap between the rear edge of the Armored Door and the front edge of the Rear Side Cab Armor Panels should be 1/8 to 3/16 in. wide.

3. Verify that the gap between the rear edge of the Armored Door and the front edge of the Rear Side Cab Armor Panels is 1/8 to 3/16 in. wide.

4. Adjust the Rear Side Cab Armor Panels with the Cab Entry Hand Hold, as necessary to achieve the proper gap, and tighten the two locknuts.
 5. Mark the attachment points on the top and second bottom hole of the Rear Cab Armor Panel using a center punch and a hammer (use the slotted holes in the top and bottom of the Panel).
 6. Remove the Rear Cab Armor Panels.
 7. Using a drill and a 3/16-in. drill bit, drill pilot holes in the positions marked.
 8. Using a drill and a 17/32-in. drill bit, drill through the pilot holes into the cab.
- b. Install the Rear Cab Armor Panels onto the cab.
1. Re-position the Cab Entry Hand Hold on the second hole from the top of the Rear Side Cab Armor Panels and secure the Panels and the Aft Armor Panel plates (P/N 113316) on the inside of the cab in place using two bolts (7/16 x 14 x 4.000 LG), four flat washers (7/16 ID), and two locknuts (7/16 – 14). Do not tighten the bolts and nuts at this time.

NOTE

As mentioned previously, the gap between the rear edge of the Armored Door and the front edge of the Rear Side Cab Armor Panels should be 1/8 to 3/16 in. wide.

2. Verify that the gap between the rear edge of the Armored Door and the front edge of the Rear Side Cab Armor Panels is 1/8 to 3/16 in. wide.
 3. Once the Rear Side Cab Armor Panels, with the Cab Entry Hand Hold, are adjusted as necessary to achieve the proper gap, torque the four locknuts (7/16 – 14) to 35 ft-lb.
- c. Repeat Steps “a” and “b” for the Rear Side Cab Armor Panels on the other side of the HEMTT cab.

5.1.9 Install the Blast Deflectors, Kit P/N 106706-3 (see Figure 36)

NOTE

HEMTT Armor Kits manufactured after 2004 may include additional mine blast components (Mine Blast Shield, P/N 111458-1, and Radius Block, P/N 11493-1). All assembly instructions are the same for kits with or without the additional components, except as noted in Section 5.1.9, Item c, Step 9.

- a. Install the Driver's-side (LH) Blast Deflector.
1. Remove the drag link from the pitman arm on the steering box to gain access to the fender supports.

A040057

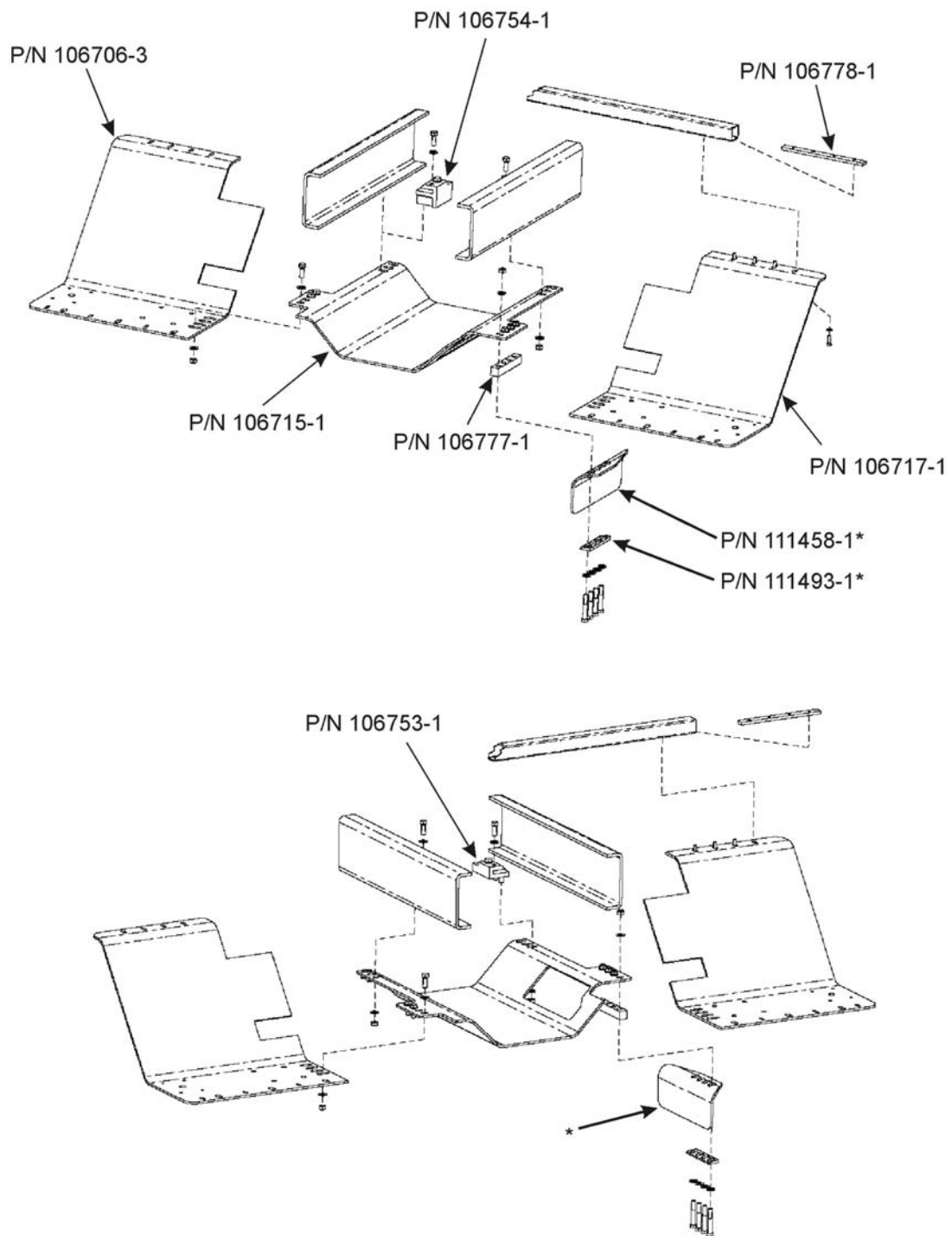

*Later versions of the kit only.

Figure 36. Blast Deflector installation (1 of 2).

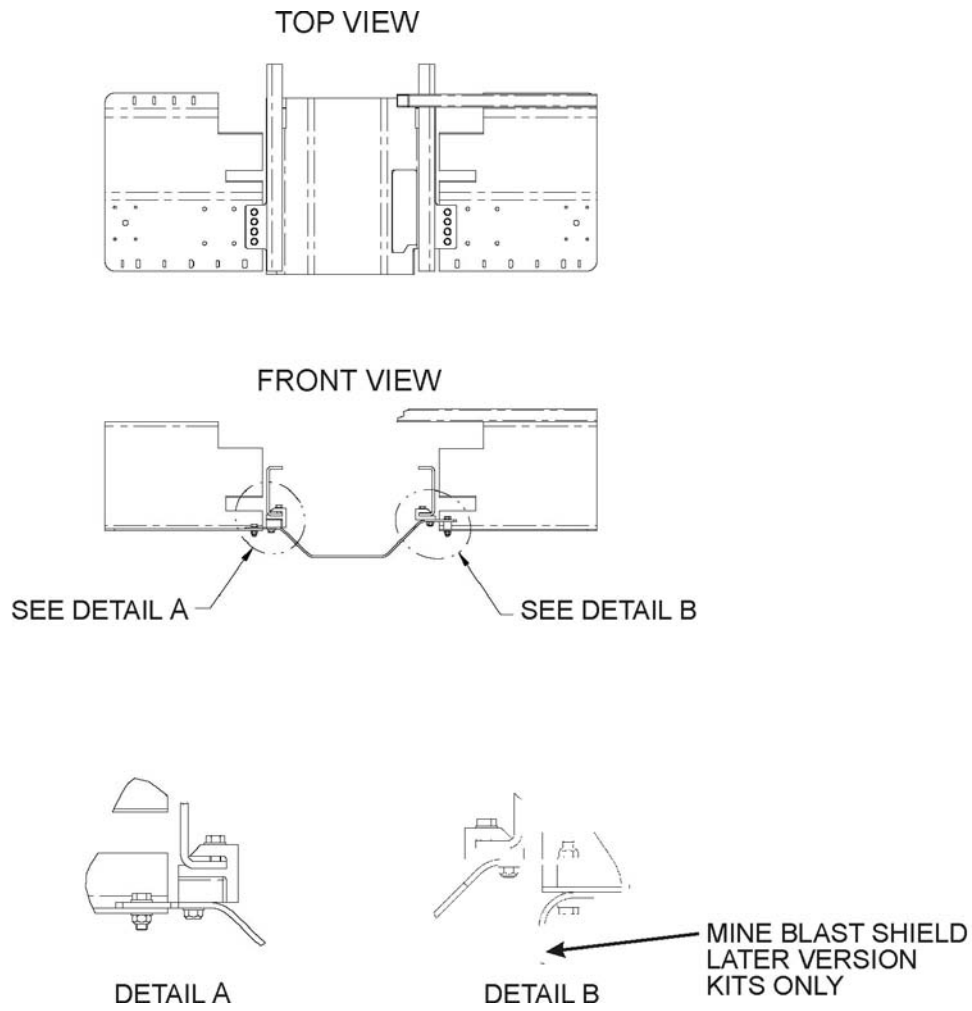

Figure 36. Blast Deflector installation (2 of 2).

CAUTION

Do not move the vehicle while the Drag Link is disconnected. This can result in hole misalignment.

- A. Remove the nut (Item 5 in Figure 36A), washer (6), and screw (7), and spread the slot in the lower end of the pitman arm.

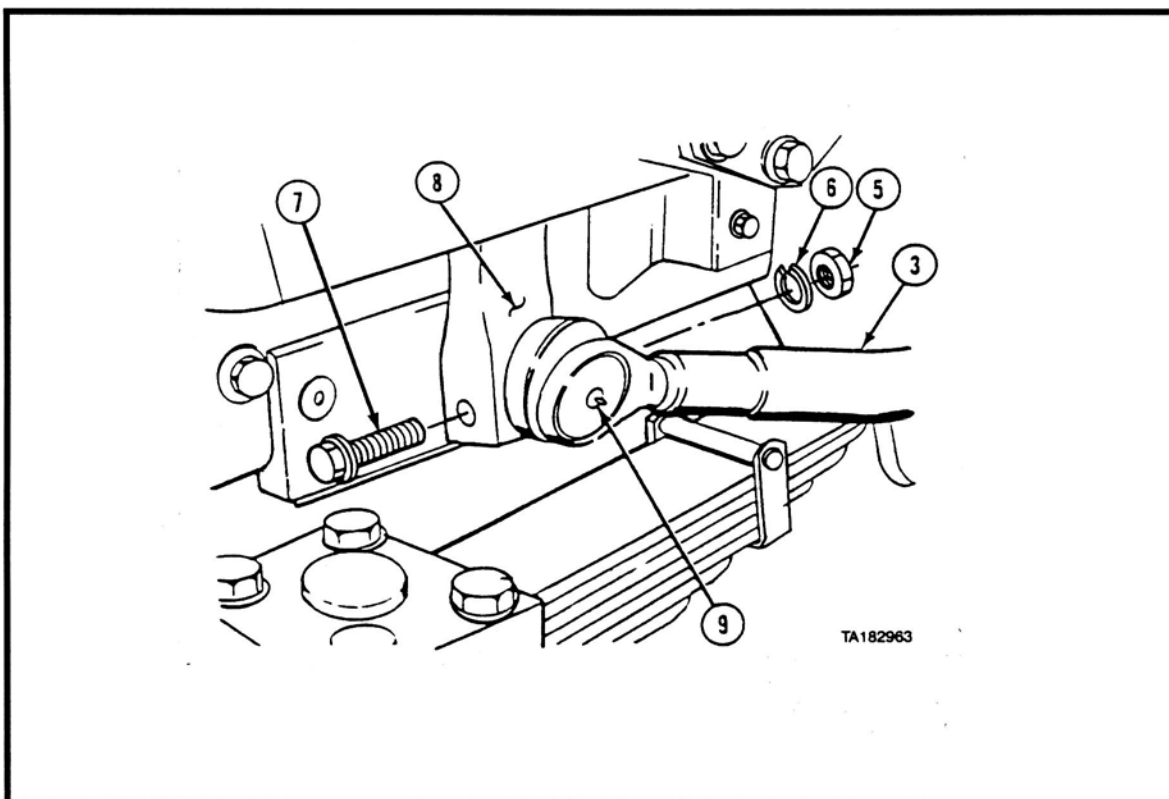

Figure 36A. Remove the drag link from the pitman arm on the steering box.

- B. Disconnect the drag link (3) from the pitman arm (8).
- 2. Use the drill template (P/N 107406-1) to locate the through-hole locations on the driver's-side fender support behind the cab (see Figure 37).
- 3. Mark and center-punch the hole locations and drill four pilot holes through the bottom surface of the driver's-side fender support using a right-angle drill and a 1/4-in. drill bit (See Figure 37A).

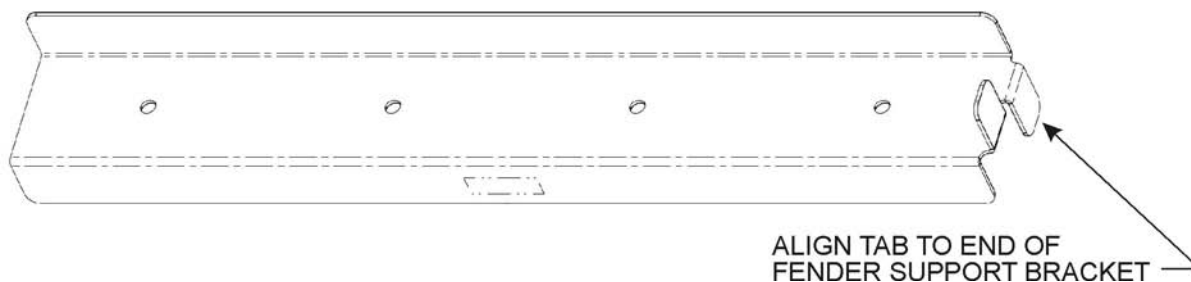

Figure 37. Drill Template (P/N 107406-1).



Figure 37A. Drill the holes for the Front Blast Deflector in the bottom of the fender support.

NOTE

Drill through the bottom of the fender support only. Do not drill through the upper surface of the fender support.

4. Using a right-angle drill and a 3/8-in. drill bit, drill through the 1/4-in. pilot holes previously drilled into the driver's-side fender support. (As an option, the vehicle's front wheels can be removed to access this area.)
5. Using a right-angle drill and a 5/8-in. drill bit, drill through the 3/8-in. pilot holes previously drilled into the driver's-side fender support.

NOTE

Doubler Plates (P/N 106719-1) are installed inside the channel of the brush guard mount, under the cab and over the existing 3.000-in.-diameter holes. The Doubler Plates are put in place to allow the use of attachment bolts on the front of the driver's-side blast deflector and lower brush guard mount. Install the Doubler Plates with the slot aligned for bolt adjustment forward and rearward.

The driver's-side Blast Deflector (P/N 106717-1) cutouts, which are on the inside edge (engine side) of the Blast Deflector, should be positioned over the cab/skid plate frame brace. Make certain that the rear upper cutout is in front of the rear cab mount that is directly behind the cab.

6. Using a suitable lifting device (forklift, jack, etc.) position the driver's-side Blast Deflector (P/N 106717-1) under the cab and secure the forward end to the bottom of the lower brush guard frame using three Doubler Plates (P/N 106719-1), three bolts (0.750 - 10 x 2.500 LG), six flat washers (0.750 ID), three locknuts (0.750 - 10). Install the locknuts finger tight at this time.
7. Install the Threaded Plate (P/N 106778-1) into the open end of the fender support and align it with the previously drilled bolt holes.
8. Install four bolts (1/2 - 13 x 1.500 LG) and four flat washers (1/2 ID) through the rear of the driver's-side Blast Deflector and the previously drilled holes in the fender support and into the Nut Plate (P/N 106778-1) (see Figure 38).



Figure 38. Install the driver's-side front blast deflector (P/N 106717-1).

- b. Install the passenger-side Front Blast Deflector, Kit P/N 106706-3.
 1. Use the drill template (P/N 107406-1) to locate the four through-hole locations on the passenger-side fender support behind the cab.
 2. Mark and center-punch the four hole locations and then drill four pilot holes through the bottom surface of the passenger-side fender support (See Figure 37) using a right-angle drill and a 1/4-in. drill bit.

NOTE

Drill through the bottom of the fender support only. Do not drill through the upper surface of the fender support.

3. Using a right-angle drill and a 3/8-in. drill bit, drill through the 1/4-in. pilot holes previously drilled into the passenger-side fender support.
4. Using a right-angle drill and a 9/16-in. drill bit, drill through the 3/8-in. pilot holes previously drilled into the passenger-side fender support.

NOTE

Doubler Plates (P/N 106719-1) are installed inside the channel of the brush guard mount, under the cab and over the existing 3.000-in.-diameter holes. The Doubler Plates are put in place to allow the use of attachment bolts on the front of the passenger-side Blast Deflector and lower brush guard mount. Install the Doubler Plates with the slot aligned for bolt adjustment forward and rearward.

The passenger-side Blast Deflector (P/N 106717-2) cutouts, which are on the inside edge (engine side) of the Blast Deflector, should be positioned over the cab/skid plate frame brace. Make certain that the rear upper cutout is in front of the rear cab mount that is directly behind the cab.

6. Using a suitable lifting device (forklift, jack, etc.) position the passenger-side Blast Deflector (P/N 106717-2) under the cab and secure the forward end to the bottom of the lower brush guard frame using three plates (P/N 106719-1), three bolts (0.750 - 10 x 2.500 LG), six flat washers (0.750 ID), and three locknuts 0.750 – 10). Install the locknuts finger tight at this time.
 7. Install the Threaded Plate (P/N 106778-1) into the open end of the fender support and align it with the previously drilled bolt holes.
 8. Install four bolts (1/2 – 13 x 1.500 LG) and four flat washers (1/2 ID) through the rear of the passenger-side Blast Deflector and the previously drilled holes in the fender support and into the Nut Plate (P/N 106778-1).
- c. Install the Center Blast Deflector, Kit P/N 106706-3.

NOTE

Install all Center Blast Deflector Brackets with the studs facing the ground.

The previously separated steering linkage must be aligned through the cutout on the driver's side of the Center Blast Deflector (P/N 106715-1) during installation.

1. Apply Loctite 242 to four bolts (0.750 – 10 x 2.000 LG) and install the bolts into the driver's-side Center Blast Deflector Bracket (P/N 106753-1) and the passenger-side Center Blast Deflector Bracket (P/N 106754-1). At this time, install the bolts only three turns to allow for adjustment.
2. Install the driver's-side Center Blast Deflector Bracket (P/N 106753-1) onto the frame rail. Install the driver's-side Center Blast Deflector Bracket with the forward surface against the rear edge of the crossmember (see Figure 36).
3. Install the passenger-side Center Blast Deflector Bracket (P/N 106754-1) onto the frame rail. Install the passenger-side Center Blast Deflector Bracket with the forward surface against the rear edge of the crossmember brace (see Figure 36).
4. Torque the four attachment bolts (0.750 – 10 x 2.000 LG) to 280 ft-lb.

NOTE

Install the driver's-side Center Blast Deflector tab (with the bolt holes) on top of the driver's-side Blast Deflector, the spacer (P/N 106777-1) between the Center Blast Deflector tab and the driver's-side Blast Deflector, and the passenger-side Center Blast Deflector tab (with the bolt holes) on the bottom of the passenger-side Blast Deflector. This can be accomplished by twisting the Center Blast Deflector and raising it into place until the driver's-side tab is above the driver's-side blast deflector and then straightening it into the proper position to allow assembly.

The previously separated steering linkage must be aligned through the cutout on the driver's side of the Center Blast Deflector (P/N 106715-1) during installation.

5. Using a floor jack or other suitable lifting device, position the Center Blast Deflector (P/N 106715-1) to the Mounting Bracket Studs (See Figure 39).
6. Secure the Center Blast Deflector to the Mounting Bracket Studs using six flat washers (3/4 ID) and locknuts (3/4 – 10) (See Figure 40).
7. Torque the six locknuts (3/4 – 10) to 280 ft-lb.
8. Install four bolts (3/4 – 10 x 2.000 LG), eight flat washers (0.750 ID), and four locknuts (3/4 – 10) through the matching bolt holes between the inside edge (engine side) of the passenger-side Blast Deflector and the outside edge (passenger side) of the Center Blast Deflector. Hand-tighten the locknuts.



Figure 39. Position the Center Blast Deflector onto the Mounting Bracket Studs.

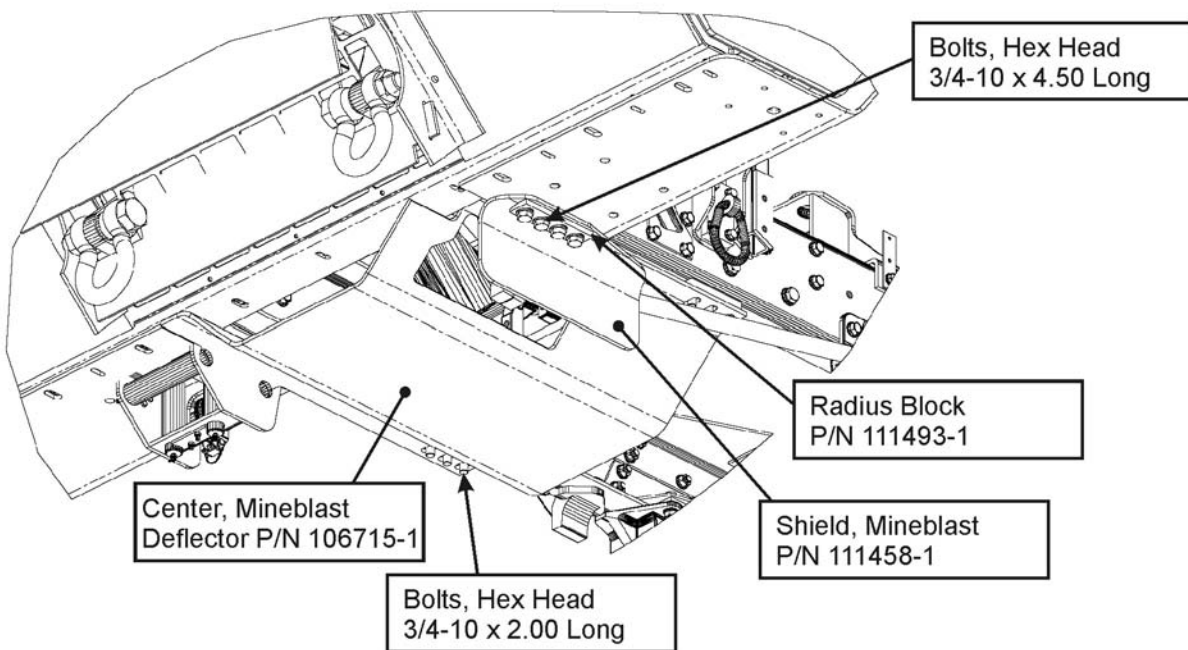

A050006

Figure 40. Secure the Center Blast Deflector to the Mounting Bracket.

9. Install four bolts (3/4 – 10 x 4.500 LG), eight flat washers (3/4 ID), and four locknuts (3/4 – 10) through the matching bolt holes between the inside edge (engine side) of the driver's-side Blast Deflector and the outside edge (driver's side) of the Center Blast Deflector. Install the Shield, Mineblast (P/N 111458) using the Radius Block (P/N 111493) (on later-model kits where it is supplied) ensuring that the drop-down section is inboard and positioned over the Center Mineblast Shield (P/N 106715) opening (see Figure 40). Hand-tighten the locknuts.
10. Torque the eight locknuts (3/4 – 10) to 280 ft-lb.
11. Torque the three locknuts (3/8 – 16) to 35 ft-lb, the three locknuts (3/4 – 10) on the forward edge of the driver's-side Blast Deflector to 280 ft-lb, and the eight bolts (1/2 – 13 x 1.500 LG) over the driver's-side rear fender support to 80 ft-lb.
12. Torque the three locknuts (3/8 – 16) to 35 ft-lb, the three locknuts (3/4 – 10) on the forward edge of the passenger-side Blast Deflector to 280 ft-lb, and the eight bolts (1/2 – 13 x 1.500 LG) over the passenger-side rear fender support to 80 ft-lb.
13. Spread the slot in the pitman arm (see Item 1 in Figure 41) and install one end of the drag link (2) into the pitman arm.
14. Install the screw (3), lockwasher (4), and nut (5) through the pitman arm and torque it to 70-80 ft-lb.

CAUTION

Ensure that adequate clearance exists between the draglink adjustment clamp and the Mine Blast Shield (P/N 111458) through the full steering range. Rotate the clamp as necessary to gain adequate clearance.

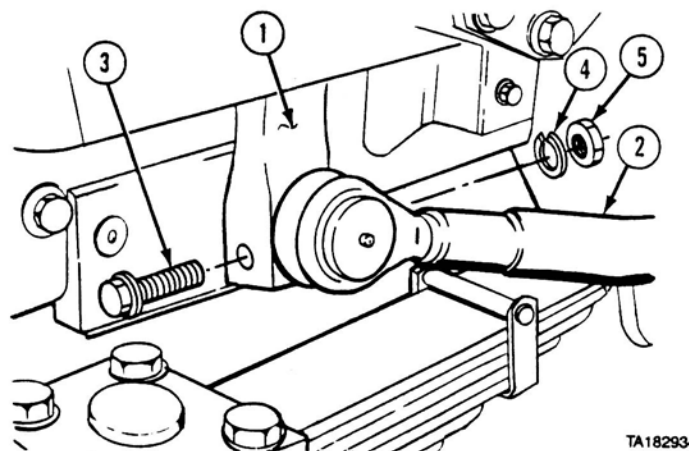

Figure 41. Re-install the drag link.

- d. Re-install the Tire Carrier and Spare Tire.
 1. Position the Tire Carrier (see Item 1 in Figure 42) on the fender (2).
 2. Install two screws (3), two lockwashers (4), and two nuts (5).
 3. Install two screws (6), two lockwashers (7), and two nuts (8) on the tire carrier (1) and the fender (2) as shown.
 4. Torque the screws (3) to 80 ft-lb.

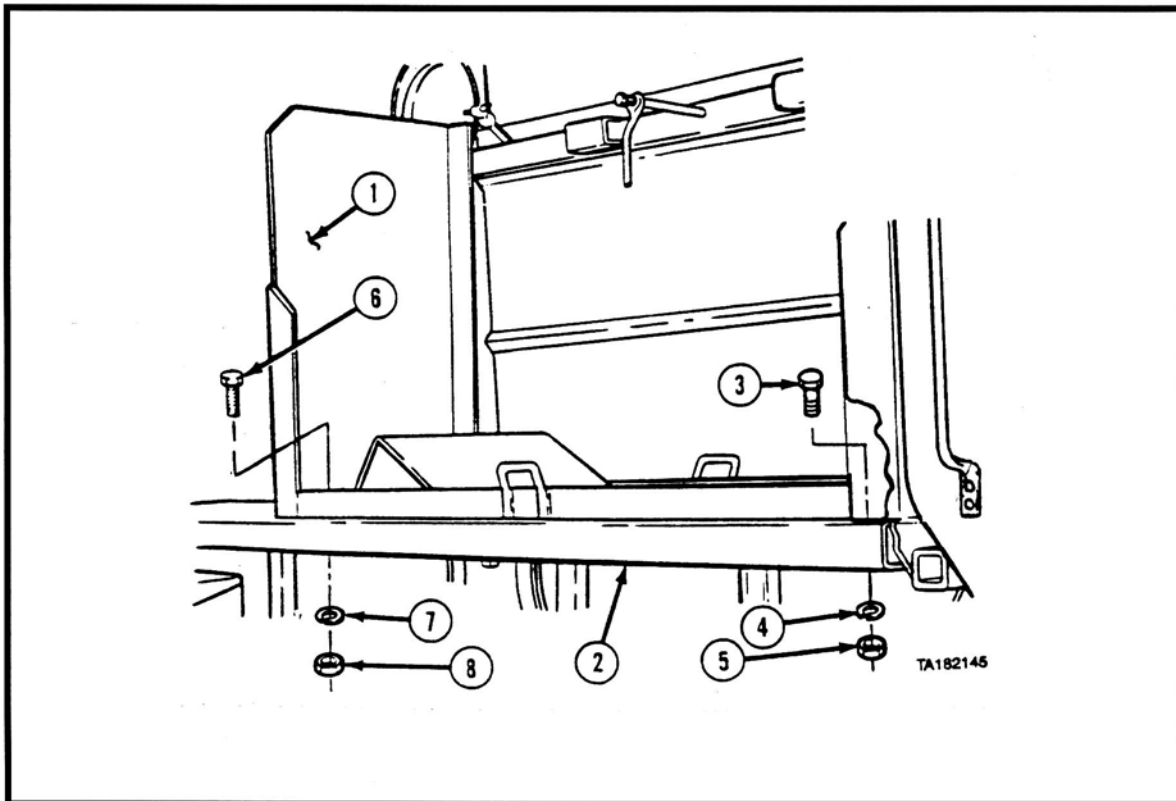

Figure 42. Re-install the Tire Carrier.

5. Torque the screws (6) to 80 ft-lb.
6. Stow the Spare Tire (Per TM 9-2320-279-10).

5.1.10 Install the Roof Armor, Kit P/N 106704-3.

NOTE

Install the Front and Rear Studplates (P/N 106780-1 / -2) through the slots in the Roof Armor and then loosely install them using locknuts (3/8 – 16) before lifting the Roof Armor Panel onto the roof of the HEMTT (See Figures 43 and 44).

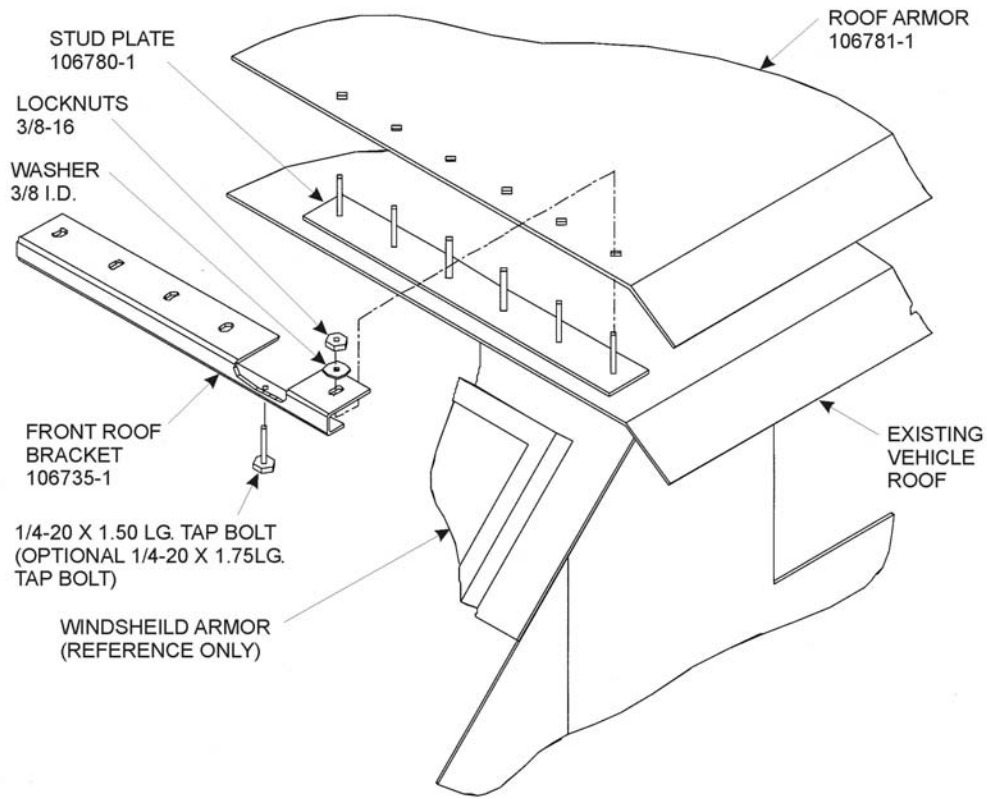

Figure 43. Roof Armor - front driver's-side installation.

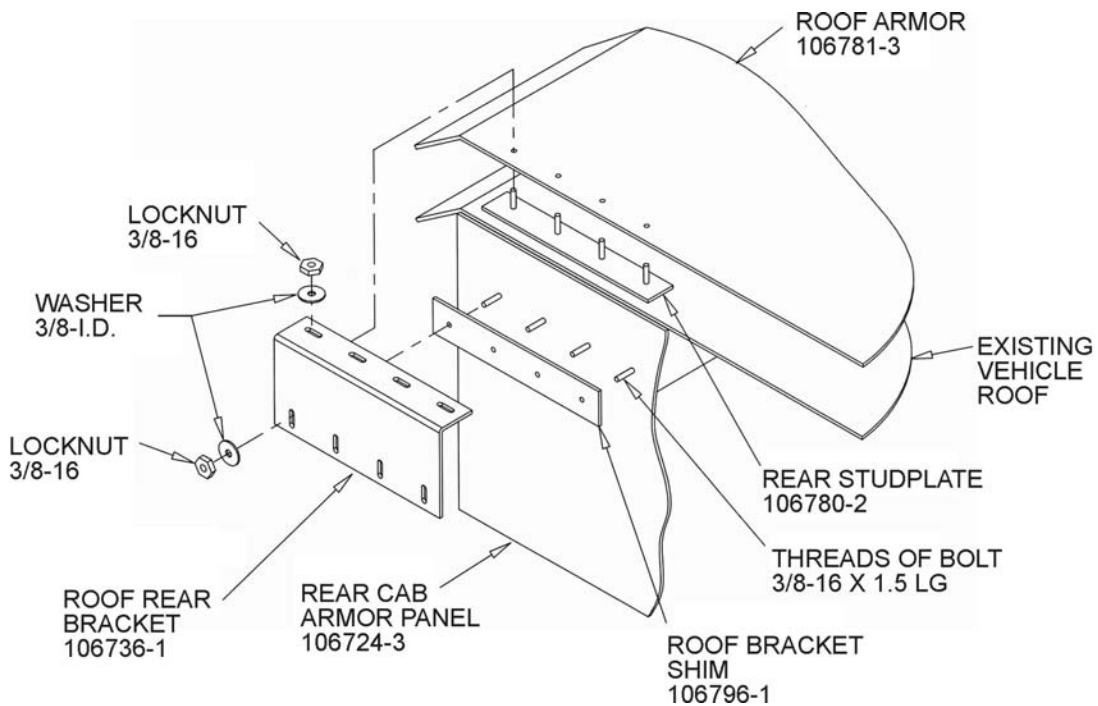

Figure 44. Roof Armor - rear driver's-side installation.

- a. Install the Escape Hatch Seal (See Figure 45). Align the edge of the seal with the side edge of the roof hatch opening.
- b. Install two Roof Channels (P/N 113347-1) on top of the cab roof using two bolts (1/4 – 20 x 1.000 LG), two washers (1/4 ID), and two locknuts (1/4 – 20) for each channel. These channels serve as a storage platform for the escape hatch (see Figure 45a).



Figure 45. Install the hatch seal.

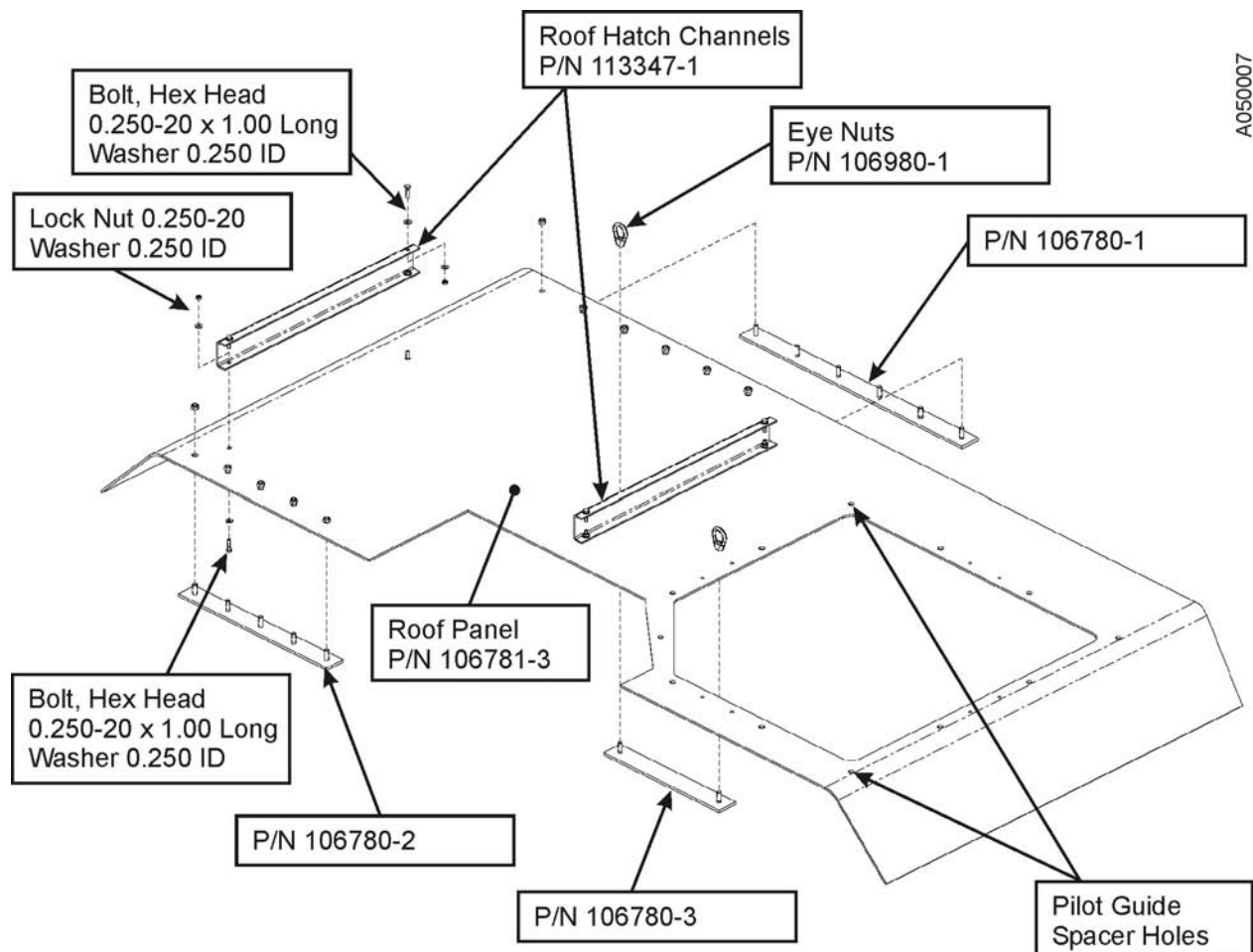

Figure 45a. Roof Armor Assembly hardware installation.

- c. Install the Stud Plate (P/N 106780-3) and two lifting eye nuts (P/N 106780-1).
- d. Install lift straps through the lifting lugs on the Roof Armor Panel (P/N 106781-3) and attach them to the appropriate material handling equipment (hoist, forklift, etc.).
- e. Apply urethane (P/N 104302) around the perimeter underside of the hatch opening prior to lifting the Roof Armor Panel into place on the roof of the HEMTT (See Figure 46).



Figure 46. Lift the Roof Armor Panel into place on the HEMTT roof.

- f. Align the 12 holes in the Roof Armor Panel with the holes in the right-hand side of the roof top.
- g. Remove the lift straps from the material handling equipment and remove the lift straps from the Roof Armor Panel.
- h. Apply Loctite 242 to 10 bolts (5/16 – 18 x 1.250 LG) and 2 bolts (5/16 – 18 x 1.750 LG).
- k. Install two bolts (5/16 – 18 x 1.750 LG), two lockwashers (5/16), two flat washers (5/16 ID), and two spacers through the two holes located on opposite diagonal corners of the Roof Armor Panel hatch opening. These bolts serve as pilot guides for the alignment of the Escape Hatch Cover.
- m. Install the 10 bolts (5/16 – 18 x 1.250 LG), 10 lockwashers (5/16 ID), and 10 flat washers (5/16 ID) through the 10 holes in the passenger side of the Roof Armor Panel. Hand-tighten the bolts.

NOTE

Use shims (P/N 106796) on the mounts between the Rear Cab Armor Panel and the Roof Armor Panel Rear Bracket (P/N 106736-1) (See Figure 43).

- n. Install four bolts (3/8 – 16 x 1.500 LG) and four washers (3/8 ID) through the Rear Cab Armor Panel from inside of the cab.
- p. Place Spacer (P/N 106796-1) over the exposed threads of the four previously installed bolts (3/8 – 16 x 1.500 LG).
- r. With the Roof Armor Panel in place, remove the locknuts loosely securing the Rear Studplate (P/N 106780-2) to the Roof Armor Panel.
- s. Install the Roof Rear Bracket (P/N 106736-1) over the exposed studs of the Rear Studplate (P/N 106780-2) and over the four bolts with a shim through the Rear Cab Armor Panel (See Figure 47).

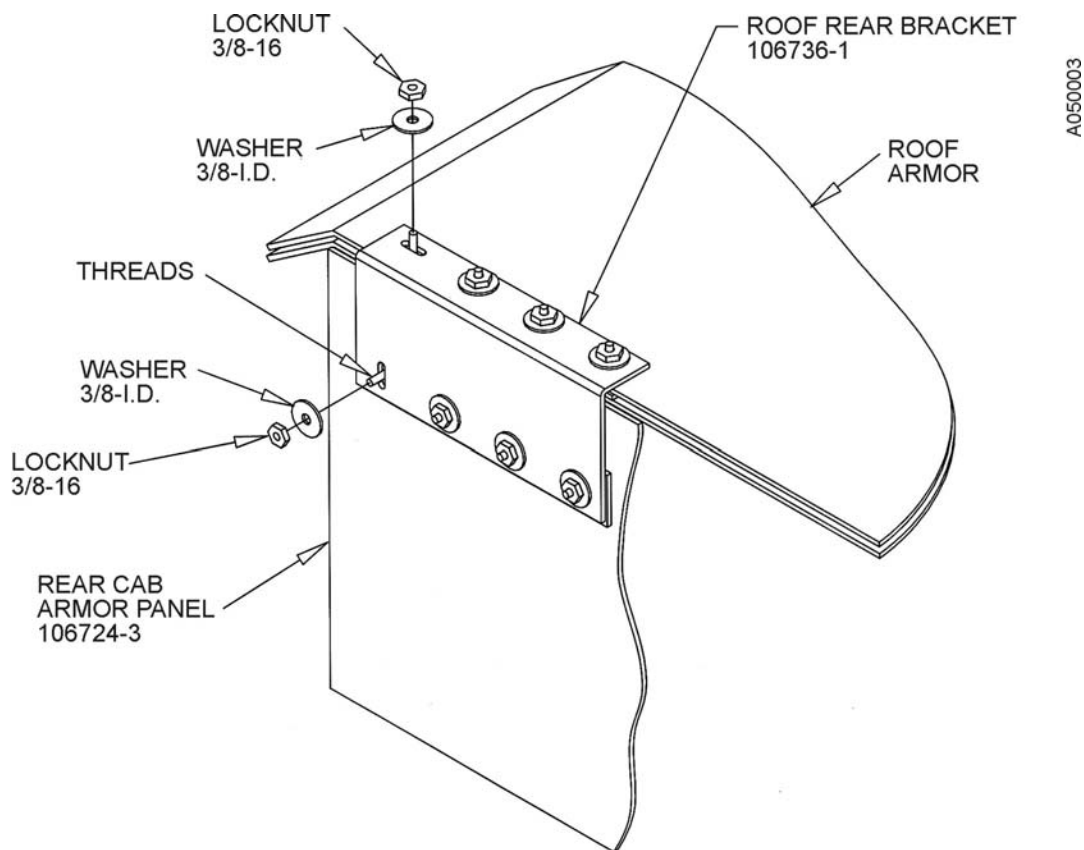

Figure 47. Position the Roof Armor Panel Rear Bracket.

- t. Install four washers (3/8 ID) and locknuts (3/8 – 16) on the top studs of the Rear Studplate (P/N 106780-2). Hand-tighten the locknuts.
- u. Install four washers (3/8 ID) and locknuts (3/8 – 16) on the rear bolts through the Rear Cab Armor Panel.
- v. Remove the locknuts loosely securing the Front Studplate (P/N 106780-1) to the Roof Armor Panel.

- w. Install the driver's-side Roof Panel Front Bracket (P/N 106735-1) over the exposed studs of the Front Studplate (P/N 106780-1) (See Figure 48).

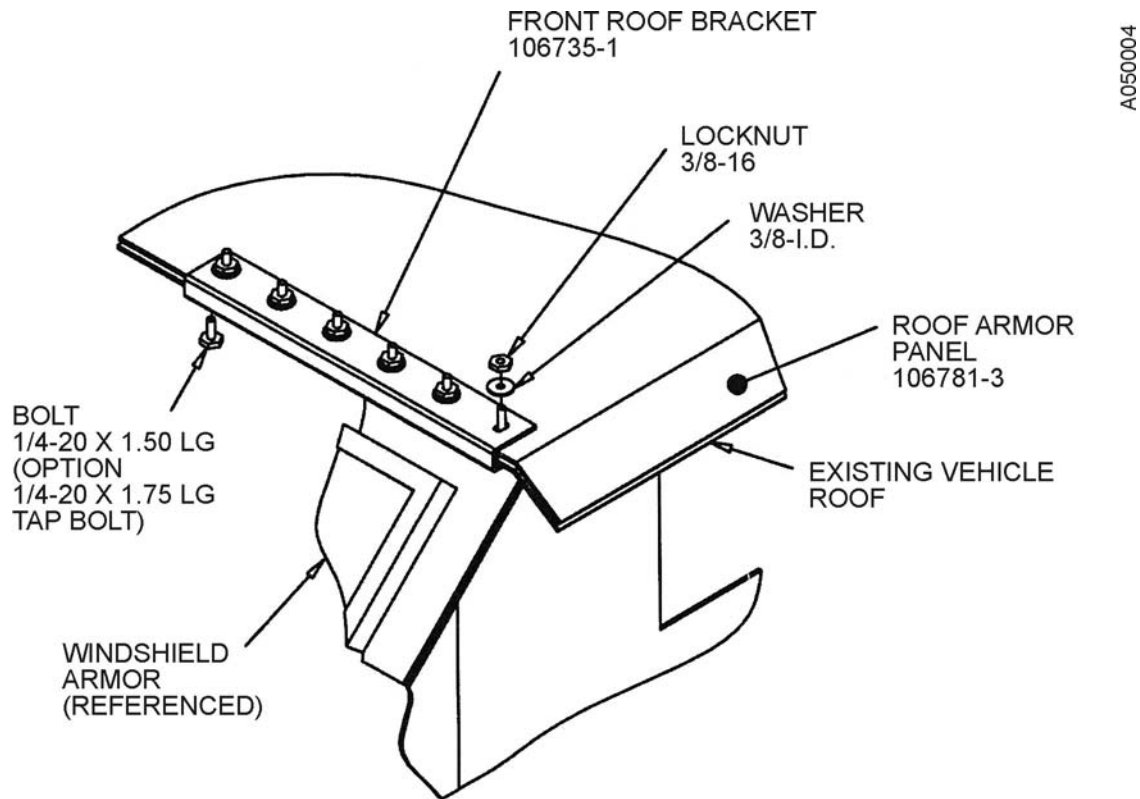

Figure 48. Secure the forward end of the Roof Armor Panel using the attachment hardware.

- x. Attach the driver's-side Roof Panel Front Bracket (P/N 106735-1) to the Studplate (P/N 106780-1) using six washers (3/8 ID) and six locknuts 3/8 – 16) (see Figure 48). Hand-tighten the locknuts.
- y. Apply Loctite 242 to five bolts (1/4 – 20 x 1.500 LG).
- z. Install the five prepared bolts (1/4 – 20 x 1.500 LG) into the bottom of the driver's-side Roof Panel Front Attachment Bracket (P/N 106735-1) (above the driver's-side windshield). Torque the bolts to 6 ft-lb.
 - aa. Torque the six locknuts (3/8 – 16) on top of the driver's-side Roof Panel Front Attachment Bracket to 23 ft-lb.
 - ab. Torque the four rear top locknuts (3/8 – 16) on top of the Rear Roof Panel Rear Bracket to 23 ft-lb.
 - ac. Torque the four locknuts (3/8 – 16) on the bolts going through the Roof Panel Rear Bracket to 35 ft-lb.

- ad. Torque the 12 Roof Armor Panel Attachment bolts (5/16 – 18 x 1.250 and 1.750 LG) (on the passenger side) to 13 ft-lb.
- ae. Install two Handles onto the top of the Escape Hatch Panel (see Figure 48A) (P/N 113346-1) using two bolts (5/16 – 18 x 1.250 LG), four washers (5/16 ID), and two nuts (5/16 – 18) for each Handle.

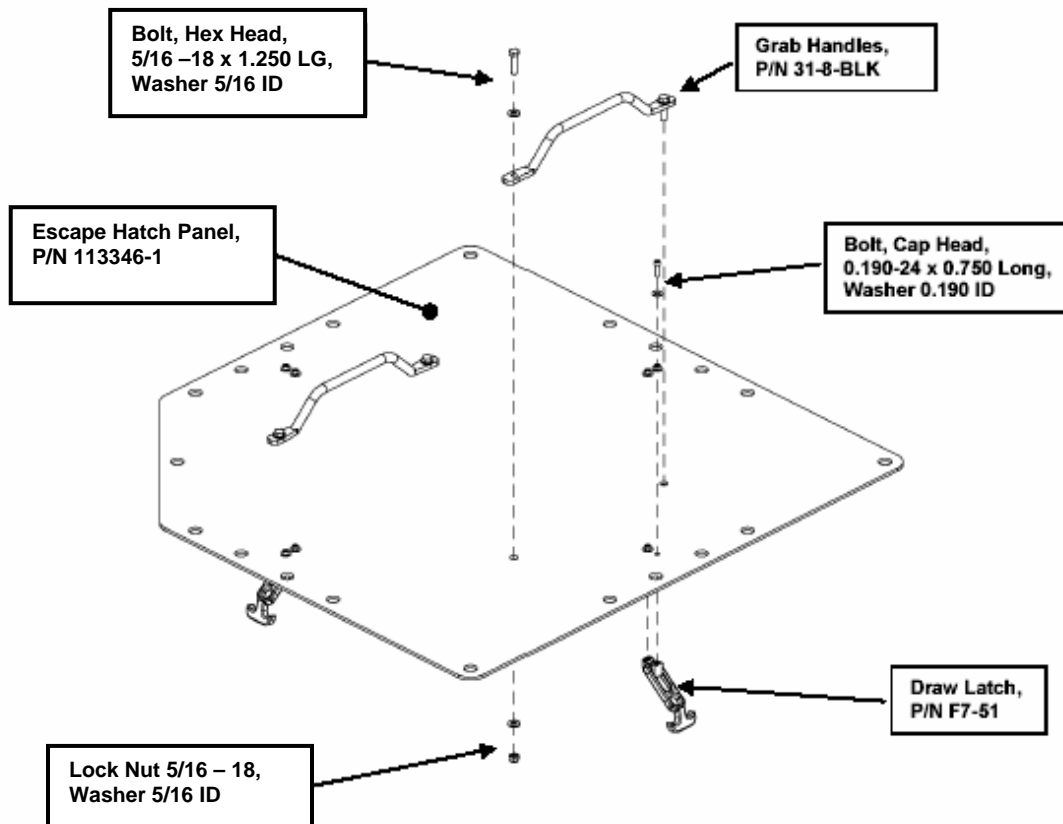

Figure 48A. Escape Hatch Handle and Draw Latch illustration.

CAUTION

Do not over-tighten the fasteners. The fasteners may strip the draw latch connector if they are over-tightened.

- af. Install four Draw Latch T-Handles (P/N F7-51) onto the bottom of the Escape Hatch Panel (P/N 113346-1) using two bolts (3/16 – 24 x 0.750 LG) and two washers (3/16 ID) for each latch.
- ag. Assemble four Keeper Pins (from the Draw Latch) into the four Escape Hatch Brackets (P/N 113357-1) with a bolt (3/16 – 24 x 1/4 LG) and a washer (3/16 ID) for each bracket.

CAUTION

Do not over-tighten the fasteners. They will strip the threaded hole in the Draw Latch Component if they are over-tightened.

- ah. Install the four Bracket Assemblies using the hardware shown, and in the locations shown, in Figure 46b. Do not fully tighten the bolts at this time.

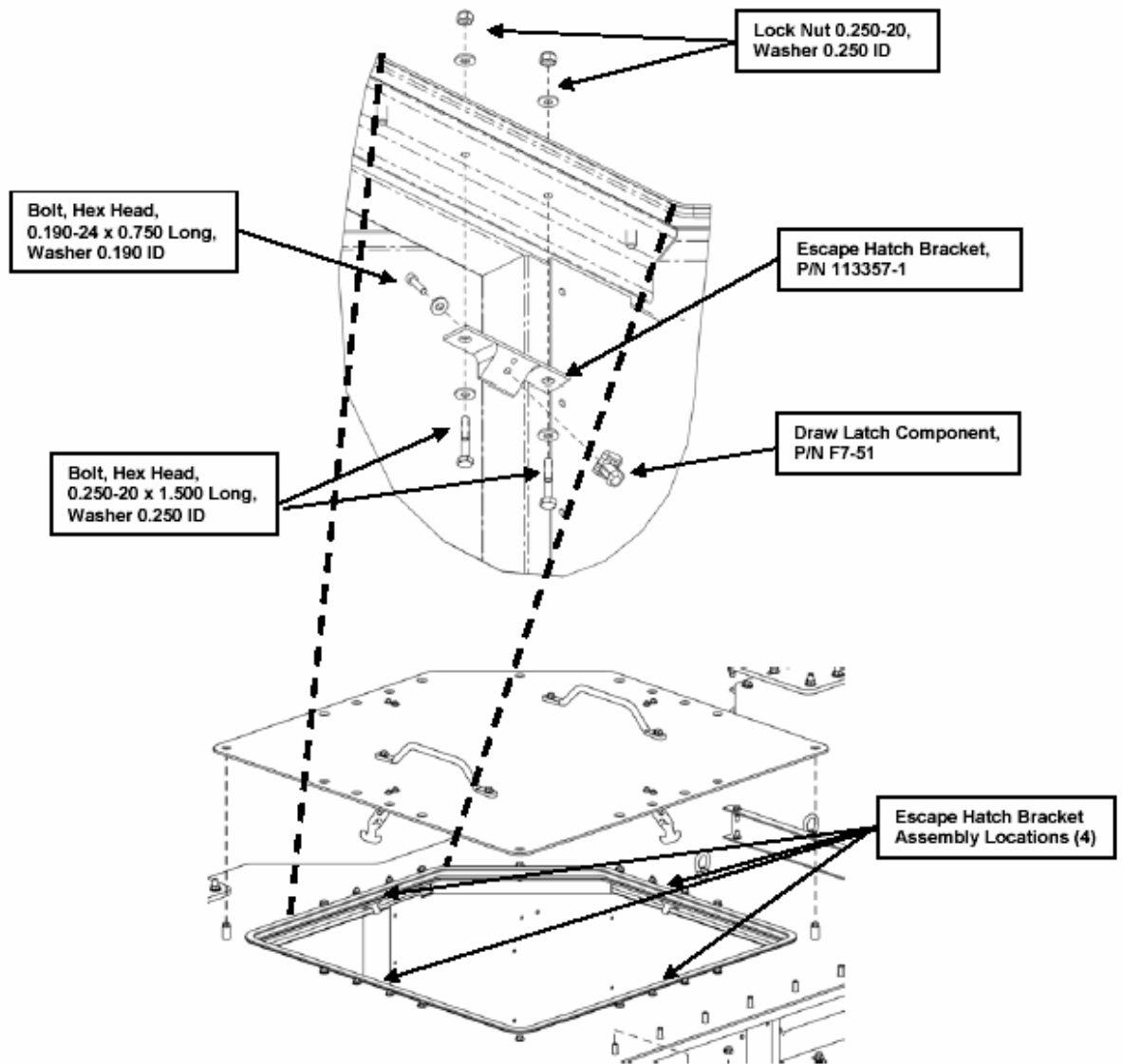

Figure 48b. Installation of the Escape Hatch Brackets.

- ak. Attach the four Escape Hatch Brackets (P/N 113357-1) to the top of the cab adjacent to the Escape Hatch (four sides) using two bolts (3/16 – 24 x 1/4 LG) and two washers (3/16 ID) for each bracket.
- am. Install the Escape Hatch in the Roof.

5.1.11 Re-Install the LH and RH Door-Mounted Outside Mirrors

- a. Position the LH outside mirror frame and mirror on the outside of the LH door.
- b. Apply Loctite 242 to four bolts (1/4 – 20 x 1.750 LG).
- c. Attach the mirror frame to the door using the four prepared bolts (1/4 – 20 x 1.750 LG), four flat washers (1/4 ID), and four locknuts (1/4 – 20).
- d. Torque the locknuts to 9 ft-lb.
- e. Repeat Steps “a” through “d” for the RH Door-Mounted Outside Mirror.

5.1.12 Re-Install the Cab Steps (with the Internal Clearance Light)

- a. Apply Loctite 242 to four bolts (5/16 – 18 x 1.250 LG).
- b. Position the hard metal cab step onto the bottom surface of the driver’s-side Blast Deflector using the four previously prepared bolts (5/16 – 18 x 1.500 LG), eight washers (5/16 ID), and four locknuts (5/16 – 18). Torque the locknuts to 18 ft-lb.
- c. Plug the wiring harness into the Clearance Light. Use the extra Pigtail Harness (P/N 111438-3) supplied in the Side Armor Panel Kit, P/N 103703-9, -10.
- d. Repeat Steps “a” through “c” for the passenger-side cab step.

5.1.13 Re-install the Blackout Light

- a. Remove the Blackout Light from the old bracket and install it in the new bracket, (P/N 111459-1), using the same hardware (see Figure 48B).
- b. Extend the vehicle Blackout Light wiring connection using the Pigtail Harness, (P/N 111438-3) supplied in the Front Armor Protection Kit, P/N 106705-3.
- c. Re-connect the vehicle Blackout Light wire connection using the Pigtail Harness, (P/N 111438-3)

5.1.14 Re-Install the Bridge Weight Sign

- a. Re-install the Bridge Weight Sign over the holes provided on the passenger side of the Upper Brush Guard Cover (P/N 111437-1) and secure it in place using two bolts (1/4 – 20 x 1.250 LG), four flat washers (1/4 ID), and two locknuts (1/4 – 20) (See Figure 49).
- d. Torque the two locknuts to 9 ft-lb.

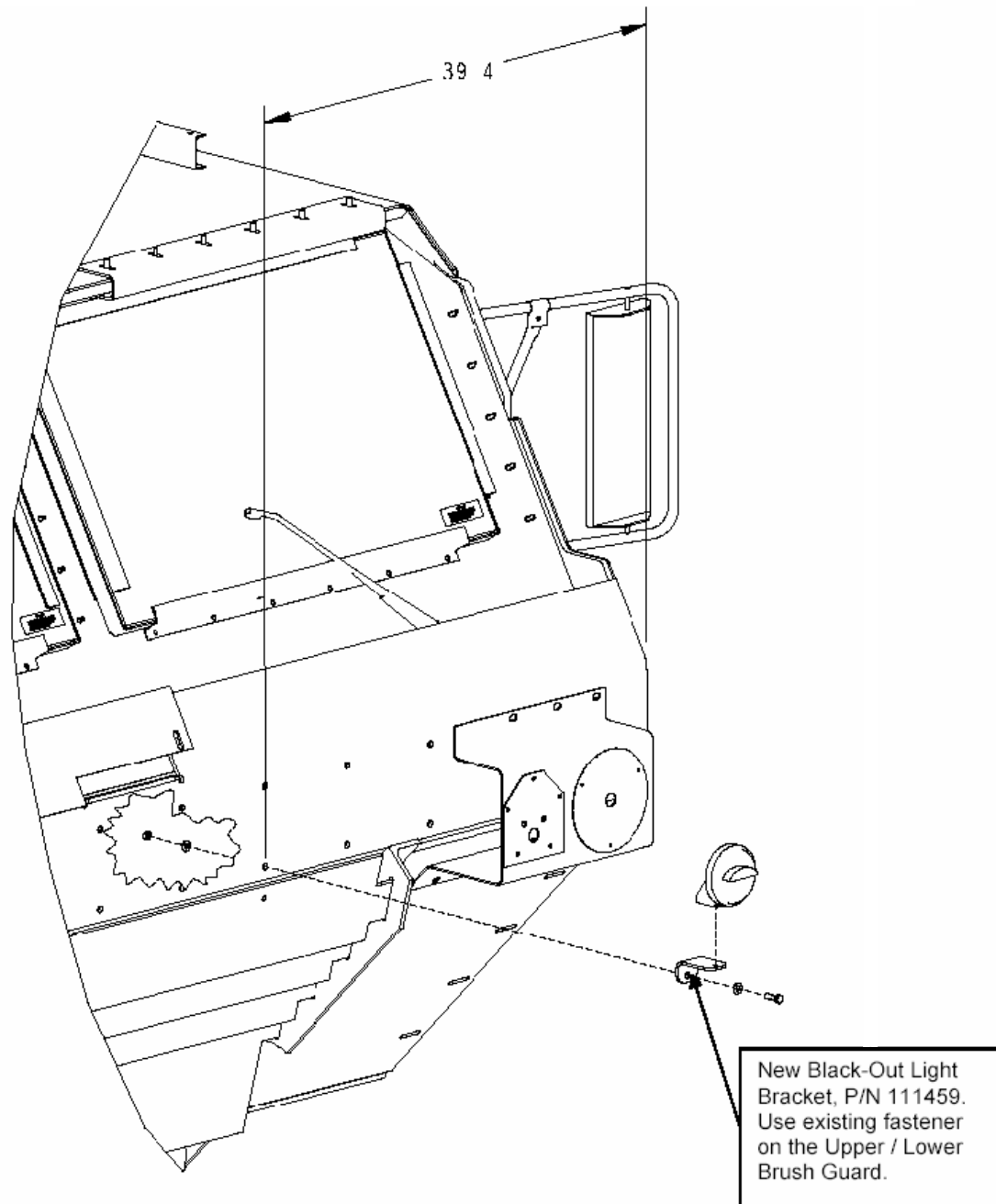

Figure 48B. Blackout Light installation.

5.1.15 Re-install the Tow Shackles

- a. Position one of the tow shackles over one of the frame ends in the front of the vehicle.
- b. Install the retaining pin attaching the tow shackle to the frame end.

- c. Install the cotter pin in the retaining pin and spread the cotter pin ends to hold it in place.
- d. Repeat Steps “a” through “c” for the remaining tow shackle.

5.1.16 Re-install the Machine-Gun Mount (if required)

- a. Reverse the Upper Brush Guard Cover (bottom to top) (P/N 111437-1) to provide a notch that allows the Machine Gun Mount support bars to attach to the Brush Guard mounting structure (See Figure 49).
- b. Hoist the Machine-Gun Mount into place on the top of the cab.
- e. Replace the nuts, bolts, and washers previously removed into the mounting brackets (two in the front and one in the back).
- f. Secure the Machine-Gun Mount in place using four bolts (3/8 – 16 x 4.500), eight washers (3/8 ID), and four lock nuts (3/8 – 16). If needed, optional longer bolts (3/8 – 16 x 4.75) are included in the Extra Fastener Kit.

5.1.17 Re-install Vehicle Identification Plates

- a. Re-install the Vehicle Identification Plates from the OEM driver’s door onto the new armored driver’s door using the urethane sealant (P/N 104302) used for the windshield installation.



Figure 49. Reversed Upper Brush Guard Cover.

APPENDIX A
FASTENER TORQUE VALUES

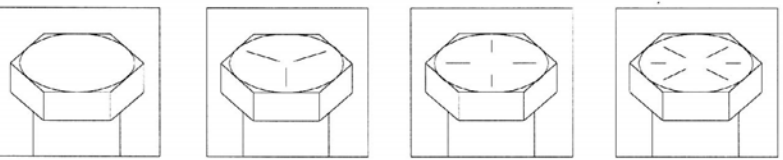
Table A-1. Torque Limits For Wet Fasteners										
CAPSCREW HEAD MARKINGS			TORQUE							
 <p>Manufacturer's marks may vary. These are all SAE Grade 5 (3-line).</p>										
			SIZE		SAE GRADE NO. 2		SAE GRADE NO. 5		SAE GRADE NO. 6 OR 7	
DIA. IN.	THREADS PER IN.	MILLIMETERS	POUNDS FEET	NEWTON METERS	POUNDS FEET	NEWTON METERS	POUNDS FEET	NEWTON METERS	POUNDS FEET	NEWTON METERS
1/4	20	6.35	4	6	6	8	8	11	9	112
1/4	28	6.35	5	7	7	9	9	12	10	14
5/16	18	7.94	8	11	13	18	16	22	18	24
5/16	24	7.94	9	12	14	19	18	24	20	27
3/8	16	9.53	15	20	23	31	30	41	35	47
3/8	24	9.53	17	23	25	34	30	41	35	47
7/16	14	11.11	24	33	35	47	45	61	55	75
7/16	20		25	34	40	54	50	68	60	81
1/2	13	12.70	35	47	55	75	70	95	80	108
1/2	20		40	54	65	88	80	108	90	122
9/16	12	14.29	50	68	80	108	100	136	110	149
9/16	18		55	75	90	122	110	149	130	176
5/8	11	15.88	70	95	110	149	140	190	170	231
5/8	18		80	108	130	176	160	217	180	244
3/4	10	19.05	120	163	200	271	240	325	280	380
3/4	16		140	190	220	298	280	380	320	434
7/8	9	22.23	110	149	300	407	400	542	460	624
7/8	14		120	163	320	434	440	597	500	678
1	8	25.40	160	217	440	597	600	814	680	922
1	12		170	231	480	651	660	895	740	1003
1-1/8	7	25.58	220	298	600	814	840	1139	960	1320
1-1/8	12		260	353	660	895	940	1275	1080	1464
1-1/4	7	31.75	320	434	840	1139	1100	1492	1360	1844
1-1/4	12		360	488	920	1248	1320	1790	1500	2034
1-3/8	6	34.93	420	570	1100	1492	1560	2115	1780	2414
1-3/8	12		460	624	1260	1709	1780	2414	2040	2776
1-1/2	6	38.10	560	760	1460	1980	2080	2820	2360	3200
1-1/2	12		620	841	1640	2224	2320	3146	2660	3607

Note: AVK Rivnuts and PEM studs are torqued to the Grade 5 values listed on the chart. Surface-resistance-welded studs are torqued to Grade 2 values listed on the chart. No. 10 bolts are torqued to 25 in.-lb. DO NOT EXCEED THE LISTED TORQUE VALUES.

**EQUIPMENT INSTALLATION INSTRUCTIONS AND PARTS LIST
FOR THE
HEAVY EXPANDED MOBILITY TACTICAL TRUCK (HEMTT)
GEN IIIB CREW PROTECTION ARMOR KIT**

Contract No. W56HZV-04-C-0259
CDRL Items A001 and A002

Prepared for:

U.S. Army Tank – Automotive Command (TACOM)
AMSTA-AQ-ATBC
Warren, MI 48397-5000

Prepared by:

Simula Aerospace and Defense Group, Inc.
7822 South 46th Street
Phoenix, AZ 85044-5354
(602) 643-7233

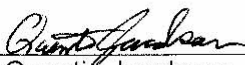
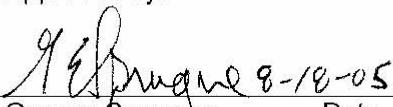
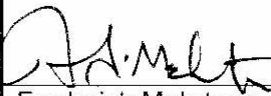
Prepared by:	Approved by:	Approved by:
 8-18-05	 8-18-05	 18 Aug 05
Quentin Jacobson Project Engineer	George Sprague ILS / R&M Engineer	Frederick Mehrrens Program Manager, HTV

THIS PAGE INTENTIONALLY LEFT BLANK

REVISIONS				
REV	CHANGED BY	DESCRIPTION	CM RELEASE	DATE
-		Initial Release (ECO 488460)		19-Aug-05

THIS PAGE INTENTIONALLY LEFT BLANK

TABLE OF CONTENTS

1. INTRODUCTION	1
1.1 GENERAL.....	1
1.2 CRATING / UNCRATING	2
1.3 SAFETY CONSIDERATIONS	2
1.4 WARNINGS, CAUTIONS, AND NOTES	2
2. DESCRIPTION AND OPERATION.....	5
2.1 GENERAL	5
3. REMOVE EXISTING HEMTT COMPONENTS	7
4. HEMTT CREW PROTECTION ARMOR KIT INSTALLATION.....	20
4.1 EQUIPMENT AND MATERIALS	20
4.2 GENERAL INSTALLATION INSTRUCTIONS.....	20
4.3 PERSONNEL SKILL LEVEL	21
4.4 PARTS LIST	21
5. CREW PROTECTION ARMOR KIT ASSEMBLY PROCEDURES.....	29
5.1 INSTALL ARMOR PANELS	29
5.1.1 Install Armor Kit, Windshield, HEMTT, P/N 106701-4	29
5.1.2 Install the Front Armor Protection Kit, P/N 106705-3.....	39
5.1.3 Install the Headlights	41
5.1.4 Install the Armored Louvered Grille	42
5.1.5 Install the Rear Cab Armor Panels – Kit P/N 106702-3.....	43
5.1.6 Install the Blast Deflectors, Kit P/N 106706-3 (see Figure 29)	48
5.1.7 Re-Install the Cab Steps (with the Internal Clearance Light).....	58
5.1.8 Install the Side Armor, Kit P/N 115500-1 (Driver’s Side).	58
5.1.9 Install the Roof Armor, Kit P/N 106704-3.....	63
5.1.10 Re-Install the LH and RH Door-Mounted Outside Mirrors	71
5.1.11 Re-install the Blackout Light	71
5.1.12 Re-Install the Bridge Weight Sign.....	71
5.1.13 Re-install the Tow Shackles	71
5.1.14 Re-install the Machine-Gun Mount (if required).....	73
5.1.15 Re-install Vehicle Identification Plates.....	73
APPENDIX A	1

THIS PAGE INTENTIONALLY LEFT BLANK

LIST OF ACRONYMS AND ABBREVIATIONS

C4ISR	Command, Control, Communications, Computers, Intelligence, Surveillance, and Reconnaissance
ft-lb	foot-pounds
HEMTT	Heavy Expanded Mobility Tactical Truck
IED	Improvised Explosive Device
in.	inch
mm	millimeter
MIL-SPEC	Military Specification
P/N	Part Number

1. INTRODUCTION

1.1 GENERAL

This document provides the Installation Instructions for the GEN IIIB Crew Protection Armor Kit for the M977 Series, 8 X 8 Heavy Expanded Mobility Tactical Truck (HEMTT). This Kit, which is manufactured by Simula Aerospace and Defense Group, Inc. (Simula), is composed of various armor panels that can be easily attached and detached from the HEMTT and stored in dedicated storage containers when they are not required.

This Kit provides the HEMTT with improved ballistic protection against mines, improvised explosive devices (IEDs), light artillery fragments, and 7.62-mm Ball projectiles. The Kit consists of Right, Left, and Center Blast Deflectors; Front, Side, Rear, and Roof Cab Armor Panels; Armored Doors; Radiator Grille Armor; Windshield and Side Window Armor, and an Armored Escape Hatch (See Figure 1).

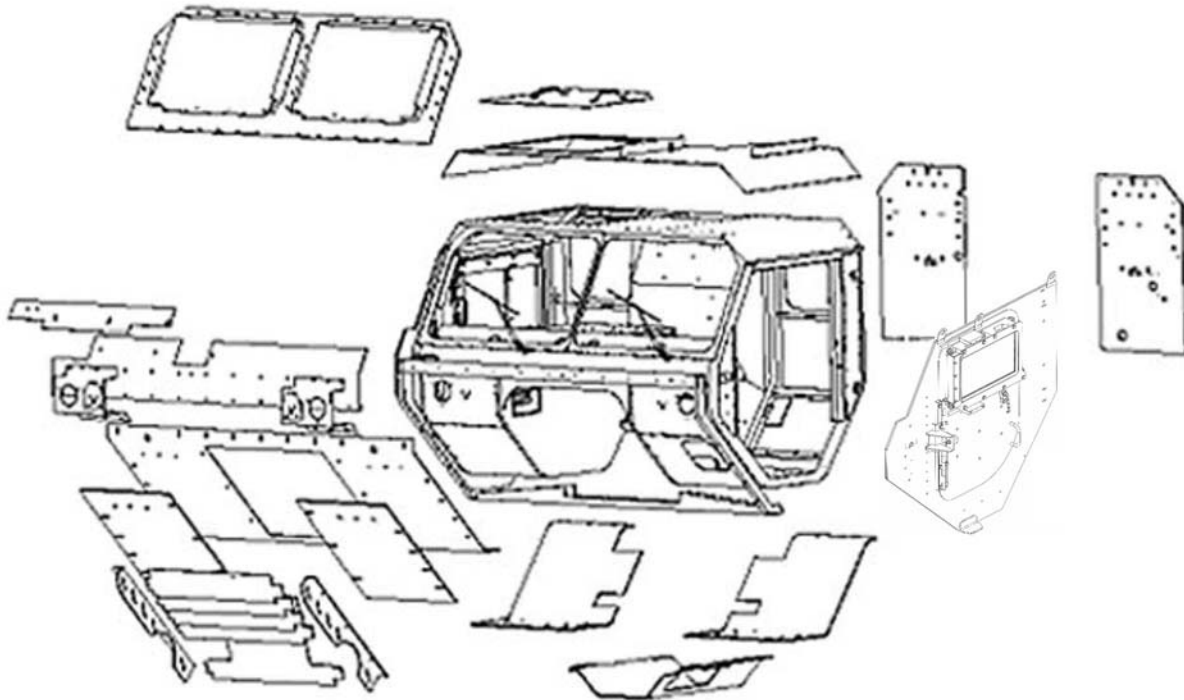

A050063

Figure 1. HEMTT Crew Protection Armor Kit component location.

1.2 CRATING / UNCRATING

Each Kit will be contained within approved shipping containers. These containers will provide the Kit's armor panels with protection and security when they are not installed on the HEMTT. Because of the weight of the specific armor panels within the Kit, care should be taken during removal of the panels from the containers or replacement of the panels back into the containers. Two personnel and mechanical aids (hoist, forklift, etc.) are required during the removal / installation of the armor panels.

1.3 SAFETY CONSIDERATIONS

The weights of the majority of the components within the Kit are heavier than allowable for one or two personnel, and the metal armor components may have sharp edges. Appropriate lifting and safety equipment, manpower, and safety precautions shall be utilized to ensure that no injuries are incurred during the installation or removal of the armor panels onto the HEMTT or during the removal or replacement of the panels into the shipping containers. Warnings, Cautions, and Notes are provided in these Installation Instructions, as appropriate, to advise the maintenance personnel of information necessary for the installation or removal of Kit components (see Figures 1-1 and 1-2). The Side Armor Panel Assemblies (including the Armored Doors) are in individual crates.

1.4 WARNINGS, CAUTIONS, AND NOTES

Warnings, Cautions, and Notes are included in these Installation Instructions to provide short, concise statements that emphasize critical or important information. Warnings, Cautions, and Notes precede the text that they affect, but follow the paragraph headings to which they apply. Warnings precede Cautions, and Cautions, in turn, precede Notes. A format example and an explanation of the function of each are provided as follows:

WARNING

WARNINGS HIGHLIGHT AN OPERATING OR MAINTENANCE PROCEDURE, PRACTICE, CONDITION, STATEMENT, ETC., WHICH, IF NOT STRICTLY OBSERVED, COULD RESULT IN INJURY TO PERSONNEL OR LOSS OF LIFE.

CAUTION

Cautions highlight an operating or maintenance procedure, practice, condition, statement, etc., which, if not strictly observed, could result in damage to, or destruction of, equipment, loss of mission effectiveness, or long-term health hazards to personnel.

NOTE

Notes highlight an essential operating or maintenance procedure, condition, or statement.

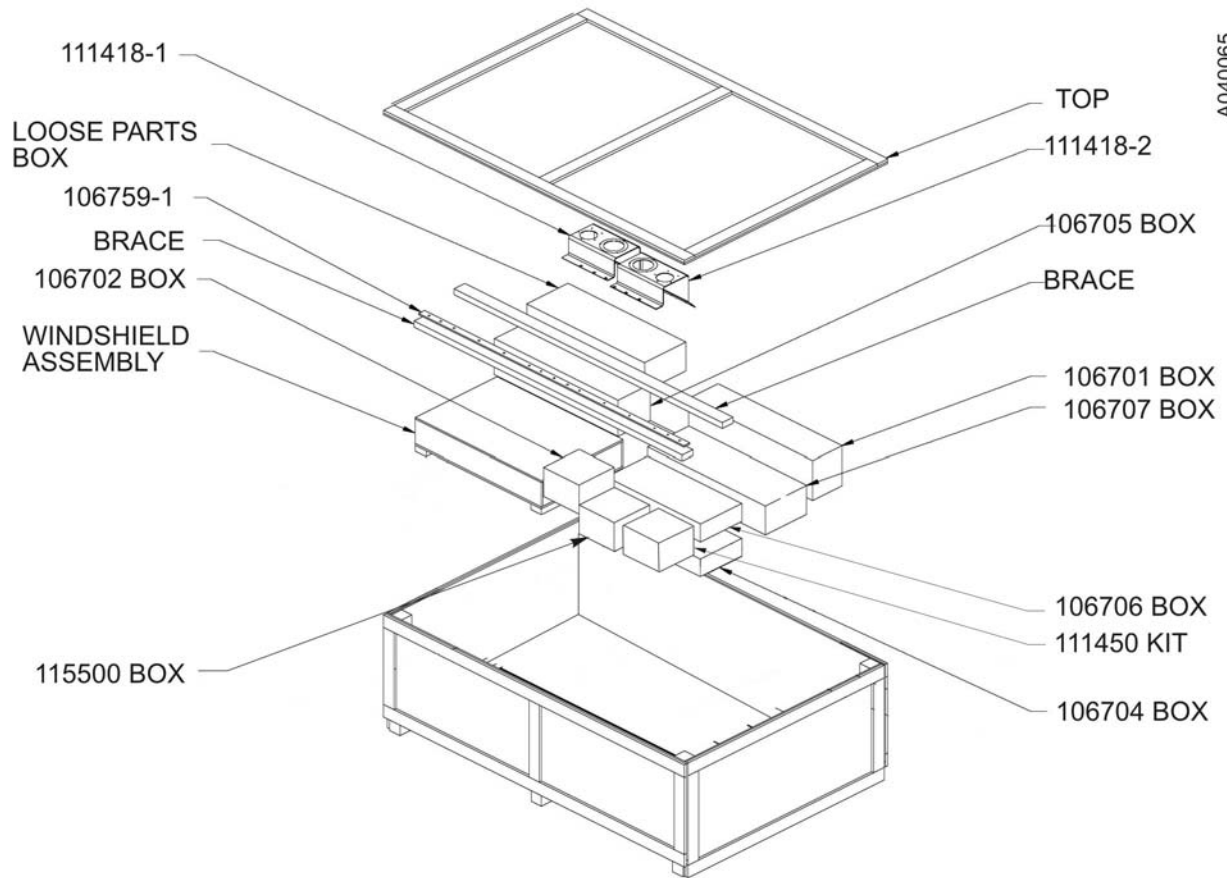

Figure 1-1. Crate No. 1 layout.

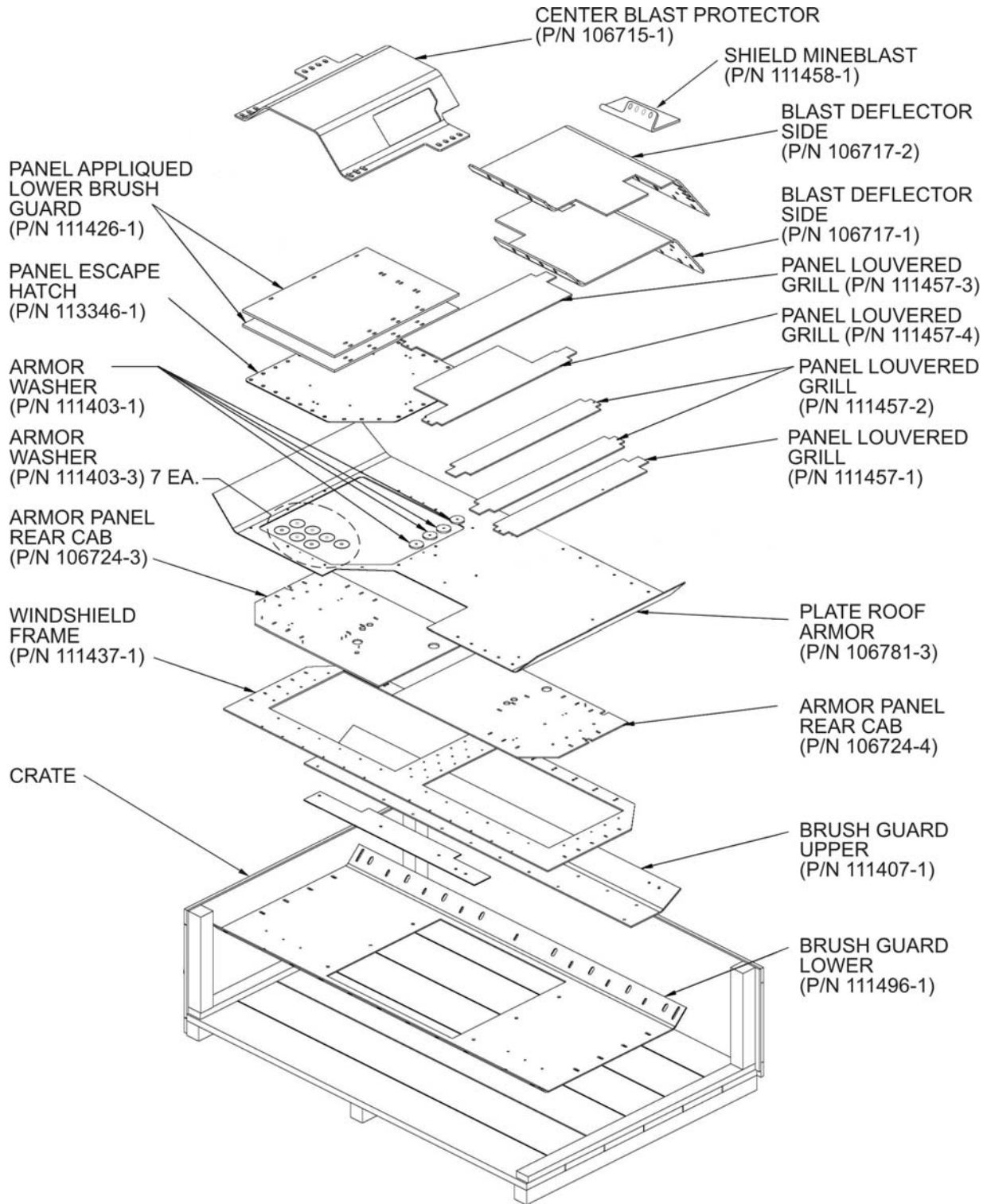

Figure 1-2. Crate No. 2 layout.

2. DESCRIPTION AND OPERATION

The physical characteristics of the HEMTT Crew Protection Armor Kit are listed in Table 1.

Table 1. HEMTT Crew Protection Armor Kit components				
Part Description	Part Number (P/N)	Weight of Part (lb)	Quantity Per Vehicle	Total Weight Per Vehicle (lb)
Windshield Frame	106721-1	123.00	1	123.00
Windshield Assy	113381-1	112.87	2	225.74
Upper Brush Guard	111407-1	131.00	1	131.00
Lower Brush Guard	111496-1	219.00	1	219.00
Louvers	111457-1, -2, -3, -4	149.00	1	149.00
Side Panel Weldment	115506-1, -2	359.55	2	719.10
Door Assy	115512-1, -2	357.00	2	714.00
Roof Armor	106781-3	166.00	1	166.00
Roof Hatch Armor	113342-1	61.00	1	61.00
Cab Rear Armor	106724-3, -4	100.20	2	200.40
Blast Deflector LHS	106717-1	145.00	1	145.00
Blast Deflector RHS	106717-2	145.00	1	145.00
Blast Deflector Center	106715-1	147.00	1	147.00
Upper Brush Guard Shim	106759-1	6.55	1	6.55
Headlight Bracket	111418-1, -2	12.60	2	25.20
Brackets, Mounts, Etc.	MISC.	225.00	1 Lot	225.00
Cover, Upper Brush Guard	111437-1	26.50	1	26.50
Panel Applique Lower Brush Guard	111426-1	49.90	2	99.80
Total Kit Weight				3,528.29
PARTS TO BE REMOVED				
Doors	-	100.00	2	200.00
Brushguard	-	112.00	1	112.00
Rear Windows	-	8.50	2	17.00
Windshield (each)	-	32.10	2	64.20
Total Weight Removed				393.20
TOTAL WEIGHT IMPACT				+3,135.09

2.1 GENERAL

The HEMTT Crew Protection Armor Kit consists of Side Armor (including Armored Doors), Roof Armor, Transparent Windshield Armor, Three Blast Deflectors, One Upper and One Lower Brush Guard, Rear Cab Armor Panels, an Armored Louvered Grille Assembly, and an Armored Escape Hatch.

The Side Armor Attachment Assembly consists of an Armor Panel that is mounted to the vehicle and is bolted in place. The Armored Door (which incorporates a sliding armored window) is bolted to the Side Armor Panel. The Roof Armor Panel is installed using the existing bolt hole pattern (used for the Machine Gun Mount) on the roof on the passenger side and the Mounting

Brackets (front and rear) on the driver's side. The Roof Armor is a one-piece panel that requires material handling equipment (hoist, forklift, etc.) for installation due to its weight. The windshield and side windows are constructed of transparent armor. The remaining armor panels are fastened to the vehicle using attachment brackets and hardware.

NOTE: If the vehicle is equipped with, or will be equipped with, C4ISR gear, use the Installation Instruction II111450 contained in the C4ISR equipment box labeled 111450-KIT.

3. REMOVE EXISTING HEMTT COMPONENTS

WARNING

THE EXISTING HEMTT DRIVER AND PASSENGER DOORS, SKID PLATE, AND SPARE TIRE ARE HEAVY ITEMS THAT REQUIRE TWO PERSONNEL OR ONE PERSONNEL AND APPROPRIATE MATERIAL HANDLING EQUIPMENT (HOIST, FORKLIFT, ETC.) FOR HANDLING. THE WEIGHTS OF THE COMPONENTS TO BE REMOVED ARE SUFFICIENT TO CAUSE SERIOUS INJURY OR LOSS OF LIFE. CARE MUST BE TAKEN DURING REMOVAL TO PREVENT INJURY.

HOISTING OPERATIONS HAVE INHERENT HAZARDS THAT CANNOT BE MECHANICALLY SAFE-GUARDED. PERSONNEL ARE REQUIRED TO WEAR HARD HATS AND SAFETY SHOES DURING THE USE OF MATERIAL HANDLING EQUIPMENT TO PREVENT PERSONAL INJURY.

NOTE

Bag and tag all removed hardware to contain it and aid in re-installation of the removed components. See Figure 2 and the accompanying table for the existing HEMTT components that need to be removed and retained for either re-use with the new armor kit or replacement when the armor kit is removed.

a. Remove the Machine-Gun Mount.

1. Attach material handling equipment (hoist, forklift, etc.) to the top ring.
2. Remove the two nuts, bolts, and washers from the mounting brackets (two front and one rear bracket).
3. Remove the Machine-Gun Mount from the vehicle.

b. Remove the Driver-Side and Passenger-Side Doors.

1. Attach material handling equipment (hoist, forklift, etc.) to the top of the Door to support its weight during the removal process.
2. Remove two screws (Item 4 in Figure 3) two washers (5), and the spacer (7) securing the Doorstrap (2) to the Door Frame (6). It is not necessary to remove the two screws (1) that secure the Doorstrap (2) to the cab.
3. While one person holds the door, have another person remove the ten bolts (9) from the hinge point on the vehicle.
4. Remove the Door (8) and the Door Hinge (10) from the vehicle.



Figure 2. Existing HEMTT components that are removed and retained.

Removed HEMTT components to be retained	
Item Removed	Number of Items
Headlights	2 ea
Front Marker Lights	2 ea
Grab Handles – Side Cab	2 ea
Side Mirrors	2 ea
Clevis	2 ea
Steps – Cab	2 ea
Cab Step Lights	2 ea
Bridge Weight Sign	1 ea
Side Cab Reflector	2 ea
Windshield Wiper	2 ea
VIN / Weight Plates	1 ea (Driver's door)
Gun Ring Components	(If equipped)
Blackout Light / Bracket	1 ea

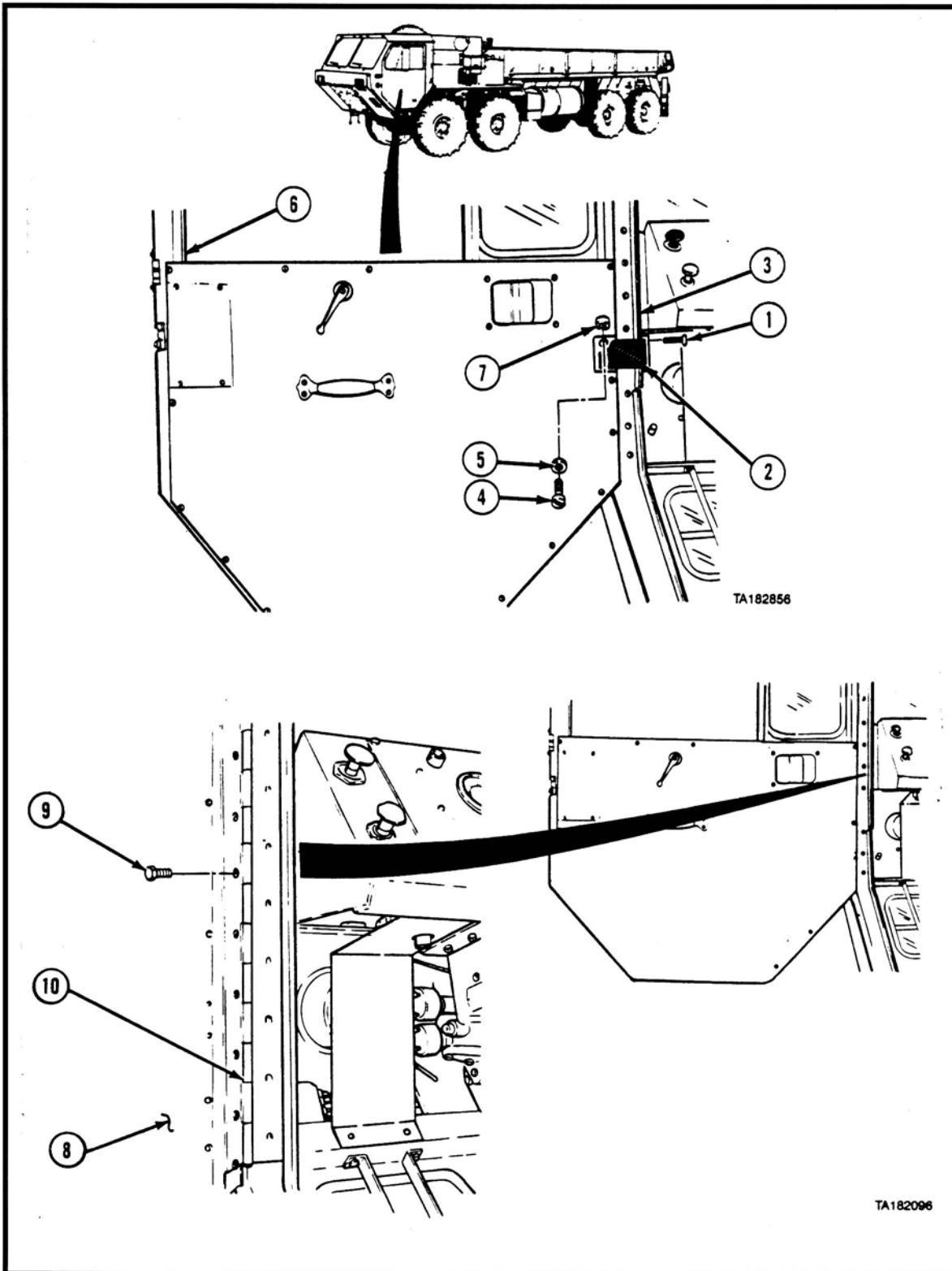

Figure 3. HEMTT Door removal.

- c. Remove the Male Dovetail and the Striker from the Door Frame of the Driver-Side and Passenger-Side Doors.
 1. Remove the two screws (Item 18 in Figure 4) that secure the Male Dovetail (19) to the Door Frame (3), and then remove the Male Dovetail from the Door Frame.
 2. Remove the nut (16) and remove the Striker (17).

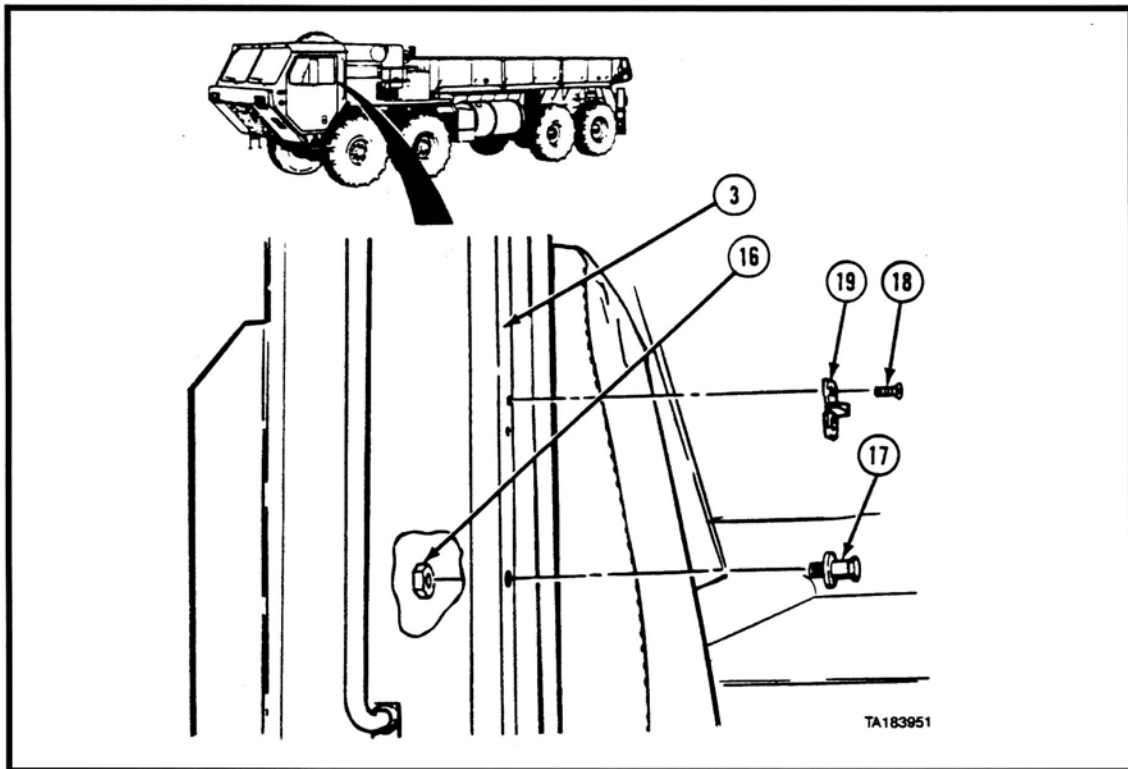

Figure 4. Remove the Male Dovetail and the Striker from the Door Frame.

- d. Remove the door-mounted Outside Mirrors from the Driver's-Side and Passenger-Side Doors.
 1. Remove the six bolts, flat washers, and nuts that secure the mirror and frame to both the Driver-Side and Passenger-Side Doors and remove the Outside Mirror from the Door.
- e. Remove the Towing Shackles.
 1. Remove the cotter pins and retaining pins that attach the Towing Shackles to the frame ends, and then remove the Towing Shackles.
- f. Remove the Skid Plate from the lower front portion of the cab.
 1. Remove nine screws (Item 1 in Figure 5) and nuts (2) from the Skid Plate.

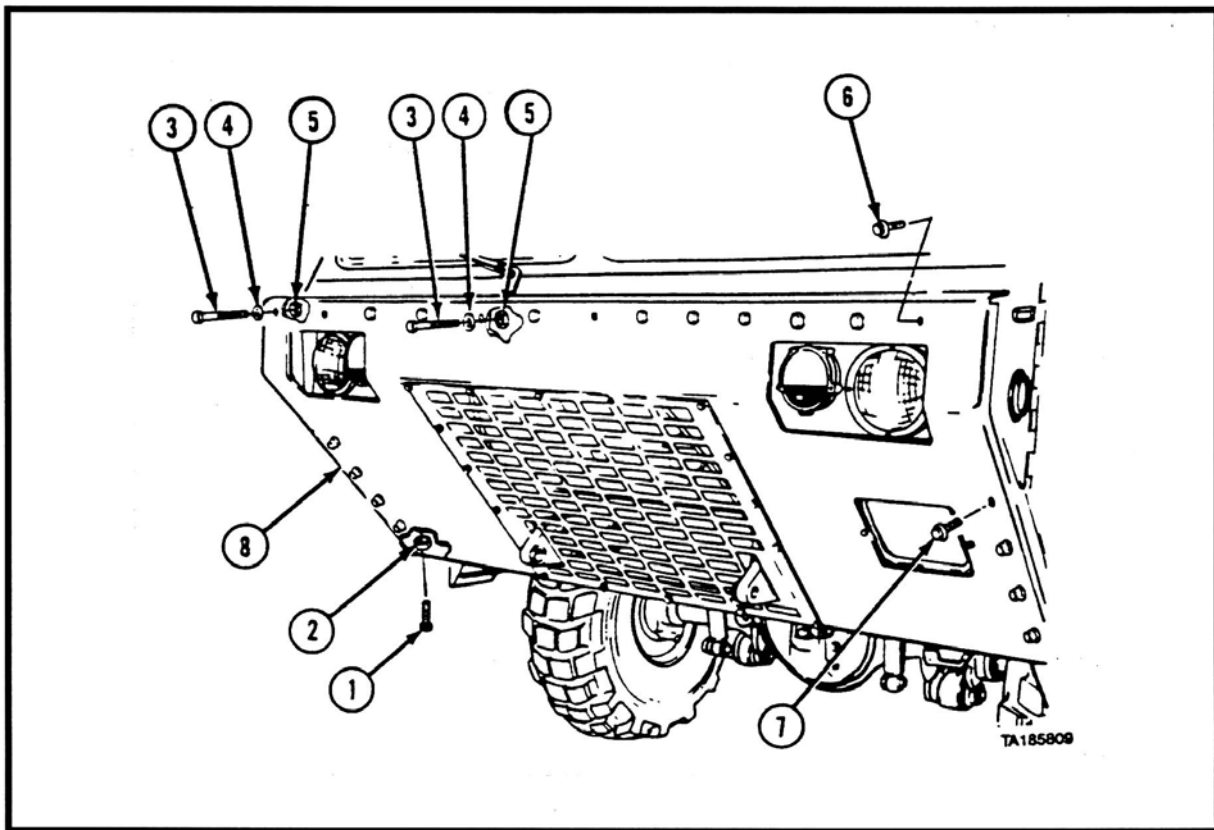

Figure 5. Removing the Skid Plate.

2. Remove two screws (3), washers (4), and nuts (5) from the Skid Plate.
 3. Remove 15 of the 17 screws (6, 7) from the Skid Plate (8), loosening but leaving in two screws (6), one on each side, at the top edge of the Skid Plate (8).
 4. While two personnel hold the Skid Plate, remove the two remaining screws (6), and remove the Skid Plate (8).
- g. Remove the Blackout Light and Bracket.
1. Remove mounting bolt, nut, and washer.
 2. Unplug wire and remove the Blackout Light and Mounting Bracket.
- h. Remove the Bridge Weight Sign from the Skid Plate.
1. Working from the back surface of the Skid Plate, remove the two bolts, lockwashers, and flat washers that secure the Bridge Weight Sign to the skid plate, and then remove the Bridge Weight Sign from the Skid Plate.
- k. Remove the Side Grab Handle from each side of the cab.

1. Remove the two nuts (Item 6 in Figure 6), lockwashers (7), flat washers (8), and bolts (9) that secure the Side Grab Handle to the cab, and then remove the Side Grab Handle from the cab.

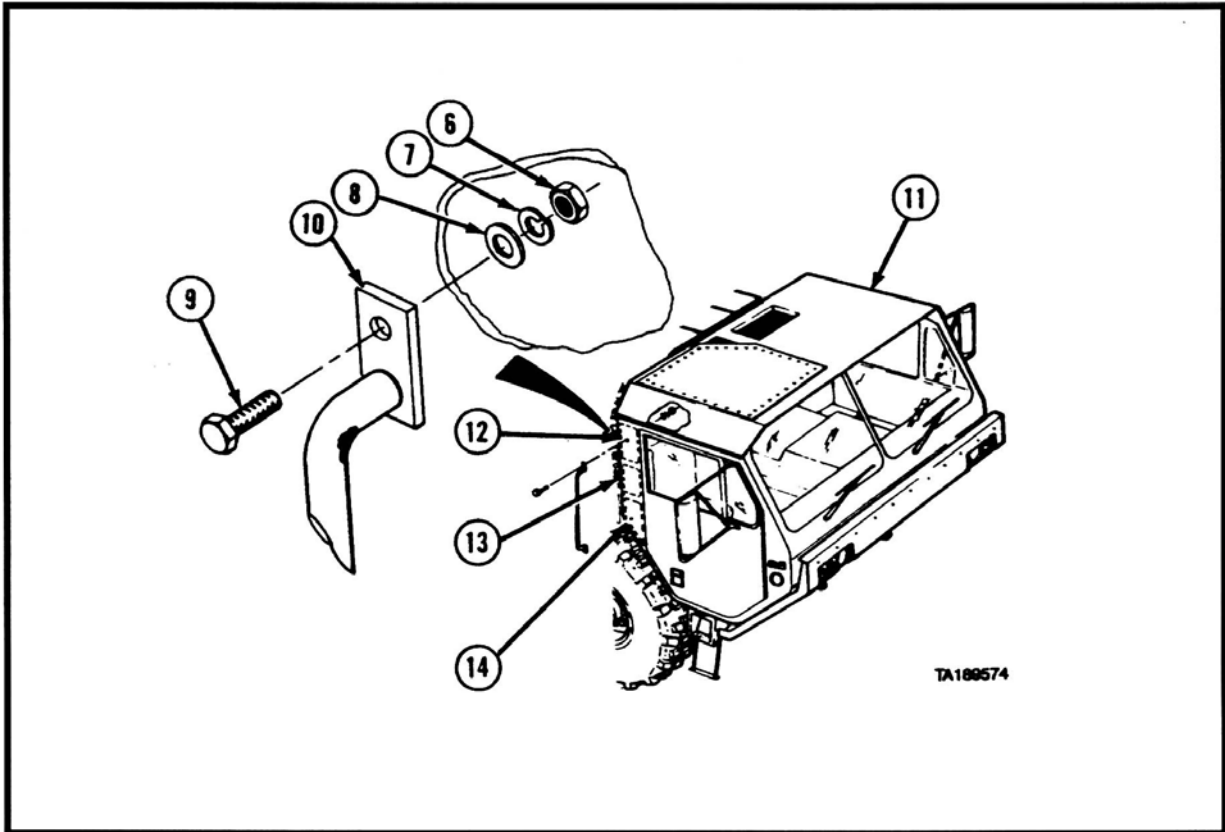

Figure 6. Remove the Side Grab Handles.

- m. Remove the Headlights (LH, RH).
 1. Remove the three screws that secure the Headlights to the cab (LH, RH). Retain the hardware for the re-installation of the Headlights.
 2. Unplug the Headlights from the wiring harness, and retain the Headlights for subsequent re-installation.
- n. Remove the Marker Lights (LH, RH).
 1. Remove the five screws that secure the Marker Lights to the cab (LH, RH). Retain the hardware for the re-installation of the Marker Lights.
 2. Unplug the Marker Lights from the Wiring Harness, and retain the Marker Lights for subsequent re-installation.
- p. Remove the Cab Step (with the integral Clearance Light) from both sides of the cab.
 1. Remove the four screws (Item 5 in Figure 7) and lockwashers (6) from the Cab Step (4), and remove the Cab Step (4) from the bottom of the cab (7).

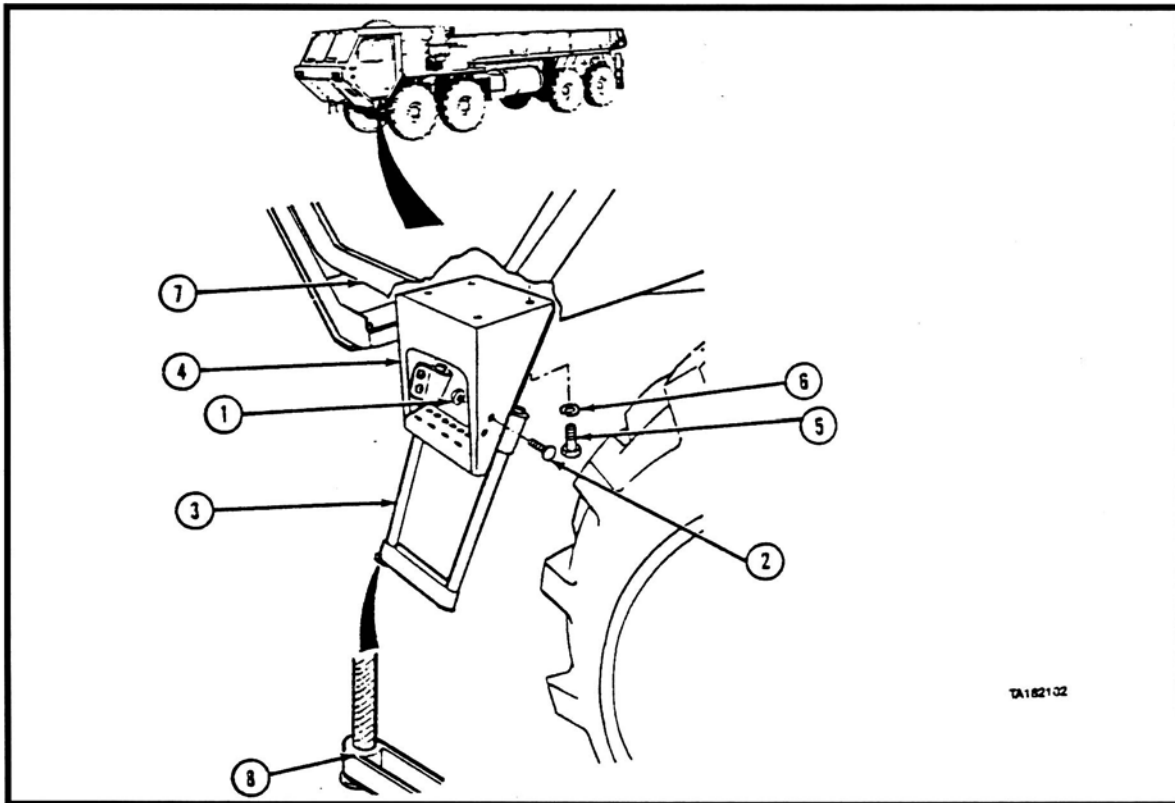

Figure 7. Remove the Cab Step.

2. Unplug the integral Clearance Light from the wiring harness.
 3. Remove the four nuts (1) and screws (2) and separate the flexible step (3) from the Cab Step (4).
- r. Remove the Cab Side Clearance Lights and Reflectors from both sides of the cab.
1. Remove the two screws that secure the amber lens of the Cab Side Clearance Light that is located on the front forward end of both sides of the cab.
 2. Remove the four mounting screws of the Cab Side Clearance Light base and separate the Cab Step Clearance Light base from the Cab Step.
 3. Position the Cab Step Clearance Light and wiring under the cab away from the cab armor installation areas.
 4. Remove the two screws that secure the amber Reflectors located on the front forward sides of the cab. Remove the amber Reflectors.
- s. Remove the Cab Top Clearance Light Bar.

1. From the inside of the cab, cut the Cab Top Clearance Light Bar wire lead 6 in. from the exit hole. Install a closed-end wire connector on the end of the wire (inside the cab), fold the wire inward, and secure it in place with a wire tie.
 2. Remove the six screws holding the Cab Top Clearance Light Bar to the cab roof overhang at the top of the windshield, and remove the Cab Top Clearance Light Bar from the vehicle.
- u. Loosen the Tire Carrier.
1. Remove the spare tire (per TM 9-2320-279-10).
 2. Remove the four screws (Item 22 in Figure 8), nuts (23), and lockwashers (24) from the Tire Carrier (18) and Fender (25).
 3. Remove the two screws (26), nuts (27), and lockwashers (28).
 4. Remove the mounting bolts, nuts, and washers from the fuel-air separator guard (See Figure 9).
 5. Slide the tire carrier out to provide access to the rear window (See Figure 10).

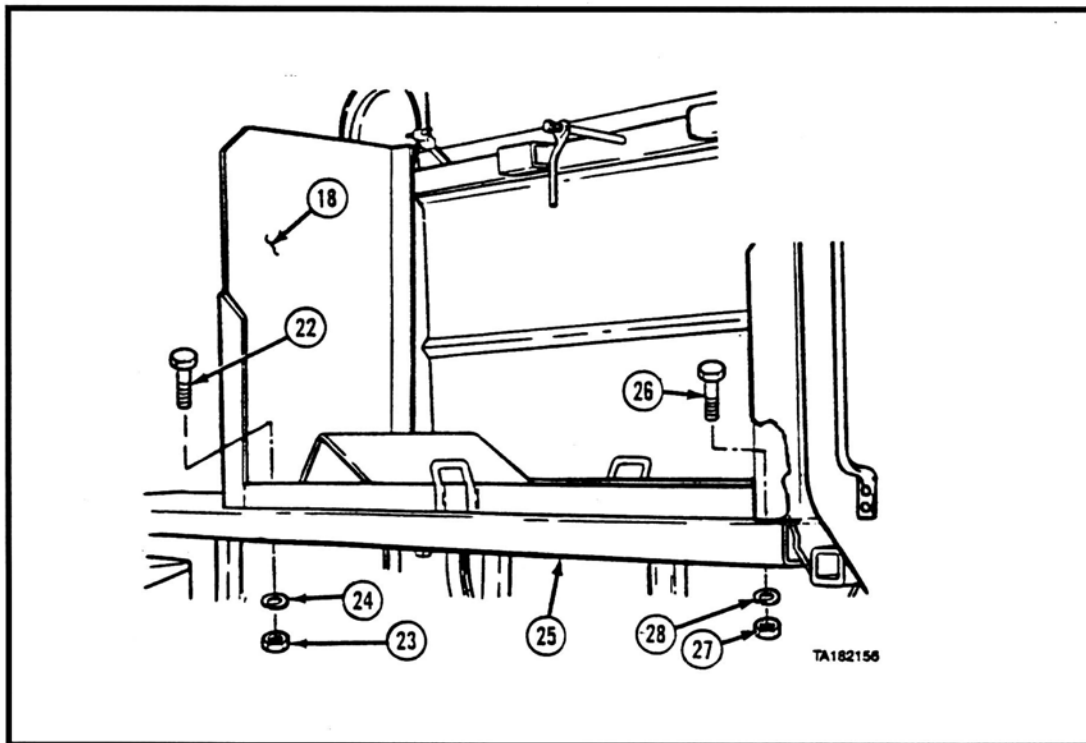

Figure 8. Loosen the Tire Carrier.



Figure 9. Remove the Fuel-Air Separator Guard.



Figure 10. Slide out the Tire Carrier.

- v. Remove the windshield wipers and windshield halves.

WARNING

THE WINDSHIELD GLASS CAN BREAK UNEXPECTEDLY DURING THE REMOVAL / INSTALLATION PROCESS. PERSONNEL ARE REQUIRED TO WEAR A FACE SHIELD, APRON, AND GLOVES.

1. Remove the nut (Item 7 in Figure 11) and lock washer (8) from the driver's-side windshield wiper drive shaft.

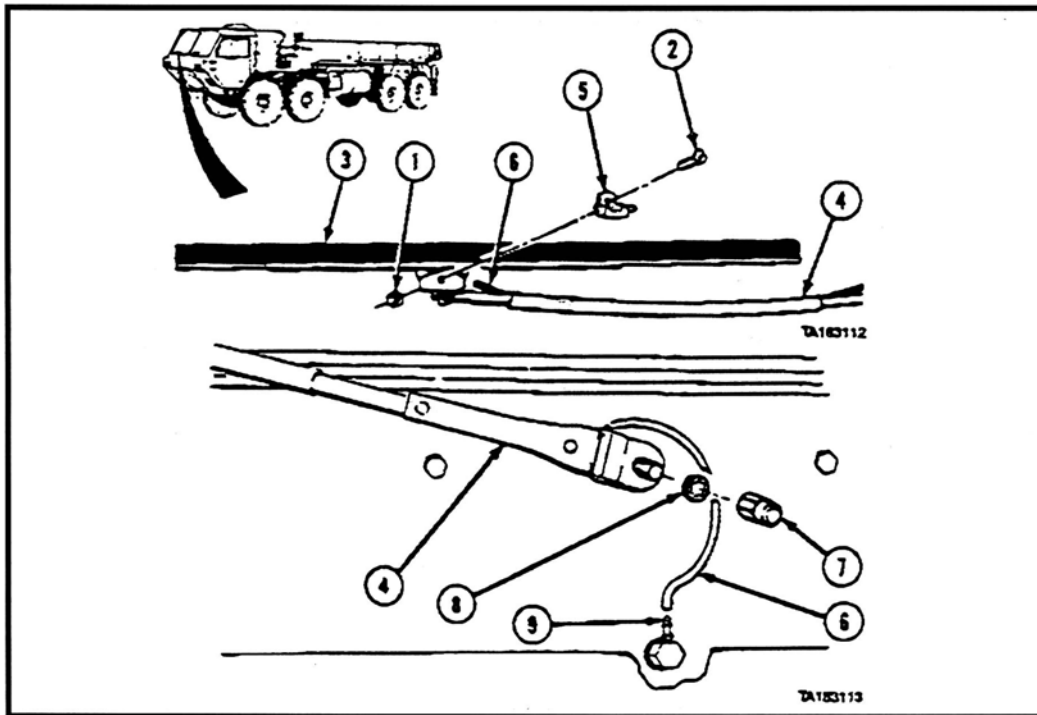

Figure 11. Remove the windshield wiper.

2. Disconnect the hose (6) from the nipple (9) and then remove the driver's-side windshield wiper and arm from the vehicle.
3. Remove the windshield weatherstripping locking strip from the center of the weatherstripping on the driver's-side windshield half.
4. From the outside of the windshield, carefully fold the inside edge of the weatherstripping out around the driver's-side windshield half.
5. With one person inside the vehicle pushing on the windshield half and one person on the outside to steady the windshield half, remove the driver's-side windshield half from the vehicle (see Figure 12).
6. Repeat Steps 15a through 15e to remove the passenger-side windshield wiper and windshield half.



NN517

Figure 12. Remove the windshield half.

w. Remove the Rear Cab Windows.

WARNING

THE REAR CAB WINDOW GLASS CAN BREAK UNEXPECTEDLY DURING THE REMOVAL / INSTALLATION PROCESS. PERSONNEL ARE REQUIRED TO WEAR A FACE SHIELD, APRON, AND GLOVES.

1. Remove the Rear Cab Window weatherstripping locking strip from the center of the weatherstripping on one of the Rear Cab Windows.
2. From the outside of the Rear Cab Window, carefully fold the inside edge of the weatherstripping out around the Rear Cab Window.
3. With one person inside the vehicle pushing on the Rear Cab Window and one person on the outside to steady the Rear Cab Window, remove the Rear Cab Window from the vehicle (See Figure 13).
4. Repeat Steps 16a, 16b, and 16c to remove the remaining Rear Cab Window.



Figure 13. Remove the Rear Cab Window.

- x. Remove the Passenger-Side Roof Panel (Machine-Gun Mount) Attachment Bolts.
 - 1. Remove the 34 bolts (Item 1 in Figure 14) that secure the Passenger-Side Roof Panel to the HEMTT roof and remove the Passenger-Side Roof Panel.

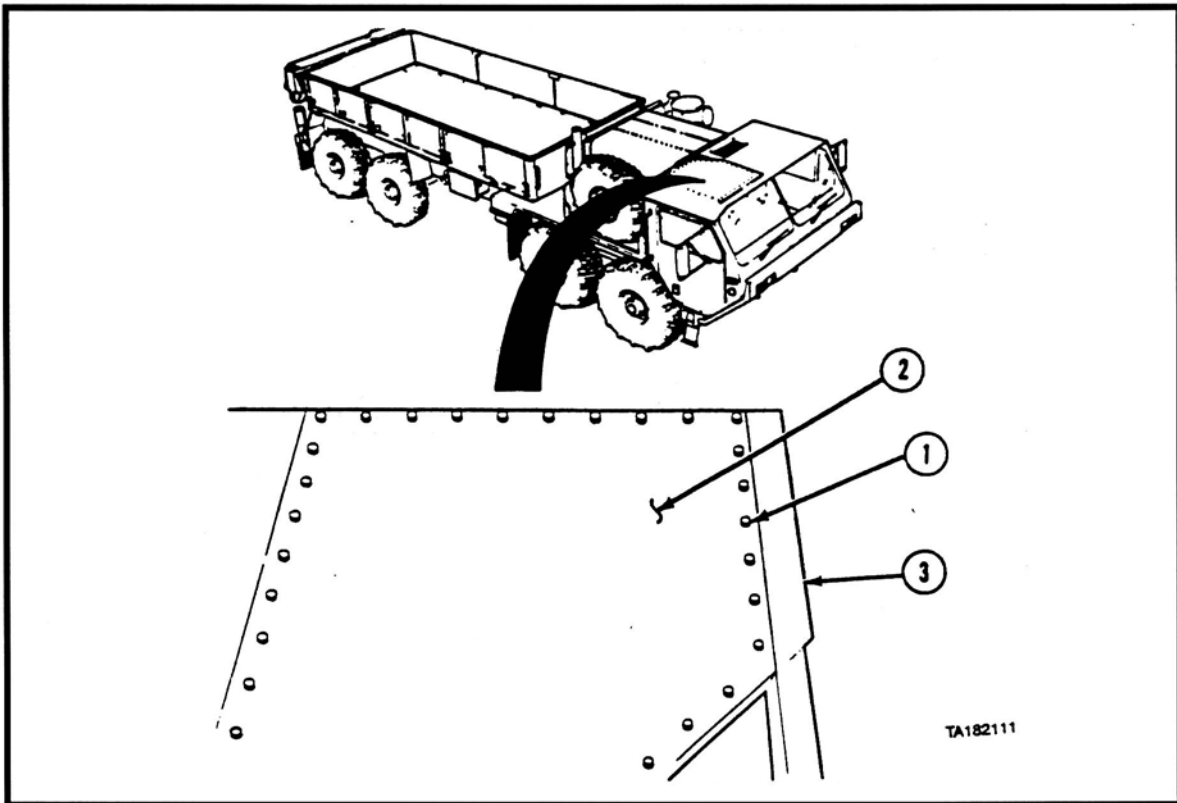

Figure 14. Remove the Passenger-Side Roof Panel (Machine-Gun Mount) Attachment Bolts.

4. HEMTT CREW PROTECTION ARMOR KIT INSTALLATION

4.1 EQUIPMENT AND MATERIALS

The equipment and materials required to install the Crew Protection Armor Kit onto the HEMTT are provided in Table 2.

Table 2. Equipment and Materials required to install the Crew Protection Kit	
Description	Part Number
Automotive General Mechanics Tool Kit	SC5180-90-N26
2.5-Ton Floor Jack	Commercially Available
8-in. C-Clamps	Commercially Available
Fork Lift / Overhead Hoist	Commercially Available
1/2-in. Drill	Commercially Available
1/2-in. Right-Angle Drill	Commercially Available
3/16-, 1/4-, 7/16-, 9/16-, 17/32-in. Drill Bits	Commercially Available
3/8-in. Drill Bit	Commercially Available
1/2-in., 5/8-in. Drill Bits	Commercially Available
Loctite 242 (Blue)	Commercially Available
Wire Ties	Commercially Available
Caulking Gun	Commercially Available
Lift Straps	Commercially Available
3/8-in.-Drive 0-90 ft-lb Torque Wrench	Commercially Available
1/2-in.-Drive 0-150 ft-lb Torque Wrench	Commercially Available
3/4-in.-Drive 0-280 ft-lb Torque Wrench	Commercially Available
5/16-in. – 18 Rivnut Installation Tool	AKPT518TAK or equivalent - Commercially Available
3/8-in. – 16 Rivnut Installation Tool	AKPT616TAK or equivalent - Commercially Available
1/4-in. – 3/4-in. Uni-Bit	Commercially Available
#50 Torx Socket	Commercially Available

4.2 GENERAL INSTALLATION INSTRUCTIONS

NOTE

These Installation Instructions will provide the illustration directly after that installation callout, and the text will be on either the same page or the facing page, where practical. All necessary information, torque values, tool numbers, and materials used will be provided so that the unit can be assembled without reference to another part of the installation instructions. **Prior to installation, check the envelope on the back cover for any supplemental instructions. Any variant configurations may require alternate fastener lengths. These fasteners are found in the Extra Fastener Kit, P/N 111444.**

- a. Before beginning the assembly of a part, remove all corrosion-preventative compound (if any) and any accumulated foreign matter.
- b. All nuts, bolts, and screws used in the installation of the Kit must be coated with Loctite 242 thread lock adhesive and tightened to standard torque values, unless otherwise stated. The locknuts supplied with the Kits do not require Loctite 242. A list of standard thread / pitch sizes and the corresponding torque values are provided in Appendix A.
- c. The following alphabetical characters are not used in this manual to eliminate their potential confusion with other numbers or letters: i, j, l, o, and q.

4.3 PERSONNEL SKILL LEVEL

The installation skill level required to complete the installation of the Kit shall be MOS 63S, Heavy Wheel Vehicle Mechanic.

4.4 PARTS LIST

The HEMTT Crew Protection Armor Kit, P/N 106700-7, is composed of 12 items as follows:

Item No.	Name	Part Number	Quantity
1	Underbody Armor Protection Kit	106706-3	1
2	Installation Kit	106707-2	1
3	Windshield Armor Protection Kit	106701-4	1
4	Rear Cab Armor Protection Kit	106702-3	1
5	Rear Cab Armor Protection Kit	106702-4	1
6	Side Armor Kit (LH)	115500-1	1
7	Side Armor Kit (RH)	115500-2	1
8	Roof Armor Protection Kit	106704-3	1
9	Front Armor Protection Kit	106705-3	1
10	Fastener Kit, Extra	111444-1	1
11	Installation Instructions	II106700-7	1
12	C4ISR Mounting Hardware Kit	111450-1	1

The Underbody Armor Protection Kit, P/N 106706-3, consists of the following parts:

Item No.	Name	Part Number	Quantity
1	Center Blast Deflector	106715-1	1
2	Blast Deflector, LH	106717-1	1
3	Blast Deflector, RH	106717-2	1
4	Doubler	106719-1	6
5	Bracket	106753-1	1
6	Bracket	106754-1	1
7	Spacer	106777-1	1
8	Threaded Plate	106778-1	2
9	Bolt, Hex Head, GR8, 5/16 - 18 x 1.500 LG	-	8
10	Bolt, Hex Head, GR8, 3/8 - 16 x 2.000 LG	-	9
11	Bolt, Hex Head, GR8, 1/2 - 13 x 1.500 LG	-	8
12	Bolt, Hex Head, GR8, 0.750 - 10 x 2.500 LG	-	6
13	Bolt, Hex Head, GR8, 0.750 - 10 x 4.500 LG	-	4
14	Nut, Hex, Self-Locking, GRC, 5/16 - 18	-	8
15	Nut, Hex, Self-Locking, GRC, 3/8 - 16	-	9
16	Washer, 5/16 ID	-	16
17	Washer, 3/8 ID	-	18
18	Washer, 1/2 ID	-	8
19	Washer, 0.750 ID	-	38
20	Nut, Hex, Self-Locking, GR8, 0.750-10	-	20
21	Bolt, Hex Head, GR8, 0.750 - 10 x 2.000 LG	-	8
22	Shield, Mine Blast	111458-1	1
23	Radius Block, Mine Blast	111493-1	1

The Installation Kit, P/N 106707-2, includes two alignment studs for the Brush Guard Armor, and consists of the following parts:

Item No.	Name	Part Number	Quantity
1	Stud	107430-1	2
2	Template, Side Blast Deflector	107406-1	1
3	Template, Side Windshield	107405-2	1
4	Template, Side Windshield	107405-1	1

The Windshield Armor Protection Kit, P/N 106701-4, consists of the following parts:

Item No.	Name	Part Number	Quantity
1	Decal	104301-1	2
2	Urethane, Sealant	104302-1	31.5 oz
3	Sealer, Ribbon	104303-1	15 ft
4	Frame, Windshield	106721-1	1
5	Bracket	106733-1	1
6	Bracket	106734-1, Alt. -5	2
7	Bracket	106734-2, Alt. -6	2
8	Bracket	106734-3, Alt. -7	2
9	Bracket	106746-1	2
10	Armor, Windshield Assembly	113381-1	2
11	Bolt, Hex Head, GR8, 1/4 - 20 x 1.750 LG	-	5
12	Bolt, Hex Head, GR8, 1/4 - 20 x 1.000 LG	-	32
13	Bolt, Hex Head, GR8, 1/4 - 20 x 0.750 LG	-	34
14	Nut, Hex, Self-Locking, GRC, 1/4 - 20	-	96
15	Washer, 1/4 ID	-	133
16	Bolt, Eye	106795-2	2
17	Washer, 3/8 ID	-	2
18	Nut, Hex, Self-Locking, GR8, 3/8 - 16	-	2
19	Extension, Windshield Wiper Shaft	111408-1	2
20	Z-Channel, Windshield Mount	113383-1	4
21	Z-Channel, Windshield Mount	113383-3	4
22	Set Screw, 10-32 x 313L	1032SSCFP-0190031	2

The Rear Cab Armor Protection Kit, P/N 106702-3, consists of the following parts:

Item No.	Name	Part Number	Quantity
1	Bracket	106734-4	4
2	Bolt, Hex Head, GR8, 1/4 - 20 x 0.750 LG	-	12
3	Nut, Hex, Self-Locking, GR8, 1/4 - 20	-	17
4	Washer, 1/4 ID, GR8, USS	-	16
5	Washer, 3/8 ID	-	2
6	Armor Panel Assembly	106724-3	1
7	Washer, Armored	111403-1	2
8	Bolt, Hex Head, GR8, 1/4 - 20 x 1.500 LG	-	2
9	Washer, Fender, 1/4 x 1.500 O.D.	-	2
10	Armor Washer, Rectangular	111491-1	1
11	Armor Washer	111403-3	1
12	Shoulder Nut	111490-1	2
13	Bolt, 0.250-20 UNC x 1-3/4, GR8	-	1
14	Bolt, 0.250-20 UNC x 1, GR8	-	4
15	Washer, GR8. 0.250 ID SAE	-	8

The Rear Cab Armor Protection Kit, P/N 106702-4, consists of the following parts:

Item No.	Name	Part Number	Quantity
1	Bracket	106734-4	4
2	Bolt, Hex Head, GR8, 1/4 - 20 x 0.750 LG	-	12
3	Nut, Hex, Self-Locking, GR8, 1/4 - 20	-	16
4	Washer, 1/4 ID, GR8, USS	-	15
5	Washer, 3/8 ID	-	2
6	Armor Panel Assembly	106724-4	1
7	Washer, Armored	111403-1	1
8	Bolt, Hex Head, GR8, 1/4 - 20 x 1.500 LG	-	1
9	Washer, Fender, 1/4 x 1.500 O.D.	-	2
10	Armor Washer, Rectangular	111491-1	1
11	Shoulder Nut	111490-1	2
12	Bolt, 0.250-20 UNC x 1-3/4, GR8	-	1
13	Bolt, 0.250-20 UNC x 1, GR8	-	4
14	Washer, GR8. 0.250 ID SAE	-	8

The C4ISR Mounting Hardware Kit, P/N 111450-1, consists of the following parts:

Item No.	Name	Part Number	Quantity
1	Plate Assembly, MTS Bracket	111449-1	1
2	Bracket, PLGR Antenna Mount	111452-1	1
3	Bolt, Hex Head, GR8, 1/4 - 28 x 1.000 LG	-	2
4	Nut, Self-Locking, GRC, 1/4 - 20	-	9
5	Nut, Self-Locking, 10 - 24	-	8
6	Washer, GR8, 1/4 ID	-	11
7	Washer, GR8, No. 10	-	8
8	Installation Instructions, C4ISR Mounting Hardware Kit	II111450-1	1
9	Nut, 1/4 - 28	-	2
10	Bolt, Hex Head, GR8, 1/4 - 20 x 0.750 LG	-	2

The Side Armor Kit (LH), P/N 115500-1, consists of the following parts:

Item No.	Name	Part Number	Quantity
1 ¹	Side Panel Weldment	115506-1	1
2 ¹	Door Assy, Armor	115512-1	1
3 ^{1,2}	Bracket, Door Stop	115569-1	1
4 ¹	Bumper, Door Stop	115563-1	1
5 ¹	Block, Mirror Spacer	115557-1	2
6	A-Pillar Bracket	115503-1	1
7	Plate, Side-Aft Panel	113316-1	4
8	Armor Washer	111403-3	3
9	Wire, Pigtail	111438-3	1
10	Grommet	111453-1	1
11	Drill Guide	111489-1	1
12 ¹	Door Striker	2T-400-52	1
13 ¹	Gasket, Door Seal	437583X3/8A	110 in.
14	Gasket, Side Seal	X-103	200 in.
15	Washer, GR8, SAE (0.250 ID)	-	9
16	Washer, GR8, USS (0.250 ID)	-	3
17	Washer, GR8 (0.312 ID)	-	9
18	Washer, GR8 (0.375 ID)	-	29
19	Washer, GR8 (0.438 ID)	-	5
20	Washer, GR8, USS (0.438 ID)	-	4
21	Washer, GR8, SAE (0.500 ID)	-	6
22	Nut, Hex, Self-Locking, GR8 (0.250 - 20)	-	3
23	Nut, Hex, Self-Locking, GR8 (0.375 - 16)	-	10
24	Nut, Hex, Self-Locking, GR8 (0.438 - 14)	-	4
25	Nut, Hex, Self-Locking, GR8 (0.500 - 13)	-	1
26	Bolt, Hex Head, GR8 (0.250 - 20 x 1.250 LG)	-	6
27	Bolt, Hex Head, GR8 (0.250 - 20 x 2.000 LG)	-	3
28	Bolt, Hex Head, GR8 (0.312 - 18 x 1.500 LG)	-	9
29	Bolt, Hex Head, GR8 (0.375 - 16 x 1.750 LG)	-	19
30	Bolt, Hex Head, GR8 (0.438 - 14 x 4.000 LG)	-	4
31 ¹	Bolt, Hex Head, GR8 (0.500 - 13 x 0.750 LG)	-	3
32 ¹	Bolt, Hex Head, GR8 (0.500 - 13 x 1.000 LG)	-	2
33	Bolt, Hex Head, GR8 (0.500 - 13 x 1.500 LG)	-	1
34	Bolt, SHCS, GR8 (0.190 - 24 x 1.000 LG)	-	4
35	Bolt, SHCS, GR8 (0.250 - 20 x 1.000 LG)	-	2
36 ¹	Bolt, SHCS, GR8 (0.250 - 20 x 3.750 LG)	-	4
37	Rivnut (0.375 - 16)	ALS4-616-150	9
38	Bushing, Headed, Press Fit (0.1875 ID x 0.375 x 0.500 LG)	H-24-8-0.1875	1
39	Bushing, Headed, Press Fit (0.1875 ID x 0.500 x 0.500 LG)	H-32-8-0.1875	1
40 ¹	Washer, GR8, SAE (0.430 ID)	-	1
41 ¹	Nut, Hex, Self-Locking, GR8 (0.438 - 14)	-	1
42 ^{1,2}	Bracket, Door Stop	115570-1	1
43	Bolt, SHCS, 0.250 - 28 x 0.750 LG	-	2

Notes: 1) Items are pre-assembled at the factory.

2) Alternate Parts - Kit will have either Item No. 3 or Item No. 42.

The Side Armor Kit (RH), P/N 115500-2, consists of the following parts:

Item No.	Name	Part Number	Quantity
1 ¹	Side Panel Weldment	115506-2	1
2 ¹	Door Assy, Armor	115512-2	1
3 ^{1,2}	Bracket, Door Stop	115569-1	1
4 ¹	Bumper, Door Stop	115563-1	1
5 ¹	Block, Mirror Spacer	115557-1	2
6	A-Pillar Bracket	115503-1	1
7	Plate, Side-Aft Panel	113316-1	4
8	Armor Washer	111403-3	3
9	Wire, Pigtail	111438-3	1
10	Grommet	111453-1	1
11	Drill Guide	111489-1	1
12 ¹	Door Striker	2T-400-52	1
13 ¹	Gasket, Door Seal	437583X3/8A	110 in.
14	Gasket, Side Seal	X-103	200 in.
15	Washer, GR8, SAE (0.250 ID)	-	9
16	Washer, GR8, USS (0.250 ID)	-	3
17	Washer, GR8 (0.312 ID)	-	9
18	Washer, GR8 (0.375 ID)	-	29
19	Washer, GR8 (0.438 ID)	-	5
20	Washer, GR8, USS (0.438 ID)	-	4
21	Washer, GR8, SAE (0.500 ID)	-	6
22	Nut, Hex, Self-Locking, GR8 (0.250 - 20)	-	3
23	Nut, Hex, Self-Locking, GR8 (0.375 - 16)	-	10
24	Nut, Hex, Self-Locking, GR8 (0.438 - 14)	-	4
25	Nut, Hex, Self-Locking, GR8 (0.500 - 13)	-	1
26	Bolt, Hex Head, GR8 (0.250 - 20 x 1.250 LG)	-	6
27	Bolt, Hex Head, GR8 (0.250 - 20 x 2.000 LG)	-	3
28	Bolt, Hex Head, GR8 (0.312 - 18 x 1.500 LG)	-	9
29	Bolt, Hex Head, GR8 (0.375 - 16 x 1.750 LG)	-	19
30	Bolt, Hex Head, GR8 (0.438 - 14 x 4.000 LG)	-	4
31 ¹	Bolt, Hex Head, GR8 (0.500 - 13 x 0.750 LG)	-	3
32 ¹	Bolt, Hex Head, GR8 (0.500 - 13 x 1.000 LG)	-	2
33	Bolt, Hex Head, GR8 (0.500 - 13 x 1.500 LG)	-	1
34	Bolt, SHCS, GR8 (0.190 - 24 x 1.000 LG)	-	4
35	Bolt, SHCS, GR8 (0.250 - 20 x 1.000 LG)	-	2
36 ¹	Bolt, SHCS, GR8 (0.250 - 20 x 3.750 LG)	-	4
37	Rivnut (0.375 - 16)	ALS4-616-150	9
38	Bushing, Headed, Press Fit (0.1875 ID x 0.375 x 0.500 LG)	H-24-8-0.1875	1
39	Bushing, Headed, Press Fit (0.1875 ID x 0.500 x 0.500 LG)	H-32-8-0.1875	1
40 ¹	Washer, GR8, SAE (0.430 ID)	-	1
41 ¹	Nut, Hex, Self-Locking, GR8 (0.438 - 14)	-	1
42 ^{1,2}	Bracket, Door Stop	115570-1	1
43	Bolt, SHCS, 0.250 - 28 x 0.750 LG	-	2

Notes: 1) Items are pre-assembled at the factory.

2) Alternate Parts - Kit will have either Item No. 3 or Item No. 42.

The Roof Armor Protection Kit, P/N 106704-3, consists of the following parts:

Item No.	Name	Part Number	Qty
1	Bracket	106735-1	1
2	Bracket	106736-1	1
3	Stud Plate	106780-1	1
4	Stud Plate	106780-2	1
5	Shim, Roof Bracket	106796-1	1
6	Bolt, Hex Head, GR8, 1/4 - 20 x 1.000 LG	-	8
7	Bolt, Hex Head, GR8, 5/16 - 18 x 1.250 LG	-	14
8	Bolt, Hex Head, GR8, 3/8 - 16 x 1.500 LG	-	4
9	Nut, Hex, Self-Locking, GRC, 3/8 - 16	-	15
10	Washer, 5/16 ID	-	20
11	Washer, Lock, GR8, 5/16 ID	-	12
12	Washer, 3/8 ID	-	19
13	Armor Roof Assembly	106781-3	1
14	Handle, Grab	31-8-BLK	2
15	Spacer	8080R-S-5-35	2
16	Tap Bolt, Hex Head, GR8, 1/4 - 20 x 1.750 LG	-	5
17	Washer, 1/4 ID	-	21
18	Channel Roof Armor	113347-1	2
19	Nut, Hex, Self-Locking, 1/4 - 20	-	8
20	Bulb, Seal	103B375B3X3/16E	11 ft
21	Panel, Escape Hatch	113346-1	1
22	Plate, Stud Roof	106780-3	1
23	Nut, Eye	106795-1	2
24	Bracket, Escape Hatch	113357-1	4
25	Flexible Draw Latch, T-Handle	F7-51	4
26	Nut, Self-Locking, 5/16 - 18, GRC	-	4
27	Bolt, Cap Head, 3/16 - 24 x 0.750 LG	-	12
28	Washer, 0.19-in. ID	-	12
29	Tap Bolt, Hex Head, GR8, 5/16 - 18 x 1.750 LG	-	2
30	Tap Bolt, Hex Head, GR8, 1/4 - 20 x 1.500 LG	-	5
31	Rubber Washer, (EPDM), 0.17 ID x 3/8 OD, 0.9 THK	-	8
32	Rubber Washer, (EPDM), 0.29 ID x 9/16 OD, 0.9 THK	-	4

The Front Armor Protection Kit, P/N 106705-3, consists of the following parts:

Item No.	Name	Part Number	Quantity
1	Panel, Louvered Grille	111457-1	1
2	Panel, Louvered Grille	111457-2	2
3	Panel, Louvered Grille	111457-3	1
4	Panel, Louvered Grille	111457-4	1
5	Shim, Upper Brush Guard	106759-1	1
6	Bracket, Blackout Light	111459-1	1
7	Bolt, Hex Head, GR8, 3/8 - 16 x 1.500 LG	-	29
8	Bolt, Hex Head, GR8, 3/8 - 16 x 4.500 LG	-	4
9	Bolt, Hex Head, GR8, 3/8 - 16 x 1.250 LG	-	9
10	Nut, Hex, Self-Locking, GRC, 3/8 - 16	-	31
11	Washer, 3/8 ID	-	42
12	Brush Guard, Lower	111496-1	1
13	Brush Guard, Upper	111407-1	1
14	Bolt, Hex Head, GR8, 3/8 - 16 x 1.750 LG	-	6
15	Armor Panel, Brush Guard	111426-1	2
16	Cover, Upper Brush Guard	111437-1	1
17	Headlight Bracket	111418-1	1
18	Headlight Bracket	111418-2	1
19	Harness, Pigtail, 7-Wire	111438-4	2
20	Harness, Pigtail, 1-Wire	111438-3	1
21	Grommet	111453-1	2
22	Adapter, Marker Lamp Bracket	111442-1	2
23	Cover, Headlight	113379-1	2
24	Pan Head Sheet Metal Screw, No. 14 - 0.500 LG	-	6
25	Bolt, Hex Head, 1/4 - 20 x 1.000 LG	-	10
26	Washer, 1/4-in. ID	-	20
27	Nut, Hex, Self-Locking, 1/4 - 20	-	10
28	Washer, 3/8-in. ID, USS 1-in. OD	-	20

The Fastener Kit, Extra, P/N 111444-1, consists of the following parts:

NOTE

This Kit contains extra hardware to be used in place of lost or damaged hardware described in the previously-listed kits.

Item No.	Name	Part Number	Quantity
1	Bolt, Cap Head, Internal Hex, 3/16 - 24 x 0.750 LG	-	2
2	Bolt, Cap Head, Internal Hex, 1/4 - 20 x 1.250 LG	-	2
3	Bolt, Countersunk, 3/8 - 16 x 2.000 LG	-	4
4	Bolt, Hex Head, GR8, 1/4 - 20 x 1.000 LG	-	5
5	Tap Bolt, Hex Head, GR8, 1/4 - 20 x 1.250 LG	-	6
6	Tap Bolt, Hex Head, GR8, 1/4 - 20 x 1.500 LG	-	6
7	Tap Bolt, Hex Head, GR8, 1/4 - 20 x 1.750 LG	-	6
8	Bolt, Hex Head, GR8, 5/16 - 18 x 0.750 LG	-	2
9	Bolt, Hex Head, GR8, 5/16 - 18 x 1.250 LG	-	4
10	Tap Bolt, Hex Head, GR8, 3/8 - 16 x 1.250 LG	-	8
11	Tap Bolt, Hex Head, GR8, 3/8 - 16 x 1.500 LG	-	8
12	Tap Bolt, Hex Head, GR8, 3/8 - 16 x 2.000 LG	-	4
13	Tap Bolt, Hex Head, GR8, 3/8 - 16 x 2.500 LG	-	10
14	Bolt, Hex Head, GR8, 3/8 - 16 x 4.500 LG	-	3
15	Tap Bolt, Hex Head, GR8, 1/2 - 13 x 1.500 LG	-	2
16	Bolt, Hex Head, GR8, 0.750 - 10 x 4.500 LG	-	1
17	Nut, Hex, Self-Locking, GRC 3/16 - 24	-	6
18	Nut, Hex, Self-Locking, GRC 1/4 - 20	-	20
19	Nut, Hex, Self-Locking, GRC 5/16 - 18	-	4
20	Nut, Hex, Self-Locking, GRC 3/8 - 16	-	20
21	Nut, Hex, Self-Locking, GRC 0.750 - 10	-	2
22	Rivnut, 5/16 - 18 x 0.027 - 0.150 GRIP (AVK or Equivalent)	-	2
23	Rivnut, 3/8 - 16 x 0.027 - 0.150 GRIP (AVK or Equivalent)	-	3
24	Screw, Pan Head, 3/16 - 24 x 0.500 LG	-	2
25	Washer, Flat, 7/16 ID	-	2
26	Washer, Flat, GR8, Ø 3/16 ID	-	4
27	Set Screw, 10 - 32 x 0.310	-	2
28	Washer, Flat, Ø 1/4 ID	-	28
29	Washer, Flat, Ø 5/16 ID	-	8
30	Washer, Flat, Ø 3/8 ID	-	20
31	Washer, Flat, Ø 1/2 ID	-	2
32	Washer, Flat, Ø 0.750 ID	-	4
33	Bolt, Cap Head, Internal Hex, 3/16 - 24 x 1.250 LG	-	4
34	Nut Eye, 3/8 - 16	106795-1	1
35	Bolt, Hex Head, GR8, 3/4 - 10 x 2.500 LG	-	1
36	Bolt, Hex Head, GR8, 1/4 - 20 x 4.750 LG	-	2
37	Bolt, Hex Head, GR8, 5/16 - 18 x 1.500 LG	-	6
38	Bolt, Hex Head, GR8, 7/16 - 14 x 4.500 LG	-	2
39	Bolt, Hex Head, GR8, 3/8 - 16 x 4.750 LG	-	4
40	Bolt, Internal Hex, 1/4 - 20 x 0.500 LG	-	2
41	Nut, Hex, Self-Locking, 7/16 - 14	-	2

5. CREW PROTECTION ARMOR KIT ASSEMBLY PROCEDURES

WARNING

THE EDGES OF THE METAL ARMOR PANELS MAY BE SHARP. PROTECTIVE GLOVES SHOULD BE WORN BY THE INSTALLATION TEAM TO PREVENT PERSONAL INJURY.

THE HEMTT ARMOR COMPONENTS ARE HEAVY ITEMS THAT REQUIRE MORE THAN ONE PERSON AND / OR APPROPRIATE MATERIAL HANDLING EQUIPMENT (HOIST, FORKLIFT, ETC.) FOR HANDLING. THE WEIGHTS OF THE COMPONENTS BEING INSTALLED ARE SUFFICIENT TO CAUSE SERIOUS INJURY OR LOSS OF LIFE. CARE MUST BE TAKEN DURING INSTALLATION TO PREVENT INJURY.

HOISTING OPERATIONS HAVE INHERENT HAZARDS THAT CANNOT BE MECHANICALLY SAFE-GUARDED. PERSONNEL ARE REQUIRED TO WEAR HARD HATS AND SAFETY SHOES DURING INSTALLATION TO PREVENT PERSONAL INJURY.

CAUTION

During the application of paint or the re-application of paint, care must be taken to prevent covering up installation aid markings [**THIS SIDE OUT**, up arrows (↑), etc.]. These installation aid markings must be protected during paint application by using masking tape, paper, etc.

NOTE

Adjust the installed kit components, as necessary, prior to securing / tightening the attachment hardware.

5.1 INSTALL ARMOR PANELS

5.1.1 Install Armor Kit, Windshield, HEMTT, P/N 106701-4

CAUTION

The interior surface of the ballistic transparency (armored window) is plastic. Clean only with a normal, NON-ABRASIVE glass cleaner or mild soap and water (Ref. TM 9-2320-280-10). DO NOT use solvents or high-alkaline cleaners on the ballistic transparency. DO NOT contact the inside surface of the ballistic transparency with cleaning instruments, squeegees, or other sharp objects that could cause damage to the surface. DO NOT use a scraper of any kind to remove frost or ice from the inside surface of the ballistic transparency. DO NOT use any kind of insect repellent on or anywhere near the ballistic transparency.

CAUTION

The pressed studs used in various windshield mount components are subject to damage if proper precautions are not used. DO NOT hammer on the studs, as this may cause them to separate from the brackets. DO NOT use power impact wrenches to install locknuts on these parts; use light oil on the threads and hand tools to run the nuts down. DO NOT exceed Grade 5 torque values for these studs.

Adjust the installed kit components, as necessary, prior to securing / tightening the attachment hardware.

NOTE

Torque fasteners to the values listed in Appendix A unless otherwise noted. The fasteners clamping the “J” brackets to the cab will require a torque wrench with a “crowsfoot” attachment. For windshield fastener brackets that cannot be accessed with a torque wrench, use the following guideline: Tighten the bolts to remove free play, mark the position, and turn the bolt clockwise an additional 1/2 to 3/4 of a turn.

- a. Locate and lay out all items listed in the parts list for the Windshield Armor Kit, P/N 106701-4, and the Windshield Fastener Kit, P/N 106701-904.
- b. Apply a small amount of Loctite to the 1/4 – 20 bolts and install them a few turns into the 0.250-in. threaded holes located in the Window Bracket Retainers (P/N 106734-1, -5-103, 106734-2, -6-103, and 106734-3, -7-103). The 1/4 – 20 bolts will be fully tightened once the brackets are placed on the vehicle.
- c. Place the Windshield Template (P/N 107405-1) on the vehicle, as shown in Figure 15. Place the Windshield Bracket (P/N 106734-3 or -7-103) on top of the template and against the window frame (see Figure 15). Once the bracket is located, tighten the upper and lower bolts so that the bracket clamps to the window frame of the vehicle. Do not tighten all of the bolts at this time, as adjustment may be required in the next steps. Using the same Template, install the other Windshield Bracket on the opposite side of the vehicle window frame. Remove the Template from the vehicle when complete.
- d. Place the Windshield Template (P/N 107405-3) on the vehicle, as shown in Figure 16. Place the Windshield Bracket (P/N 106734-1 or -5-103) against the Windshield Template, as shown in Figure 16. Tighten the bolts on both ends of the Windshield Bracket. Do not tighten all of the bolts at this time, as adjustment may be required in the next steps. Using the same Template, install the other Windshield Bracket on the opposite side of the window frame. Remove the Template from the vehicle when complete.

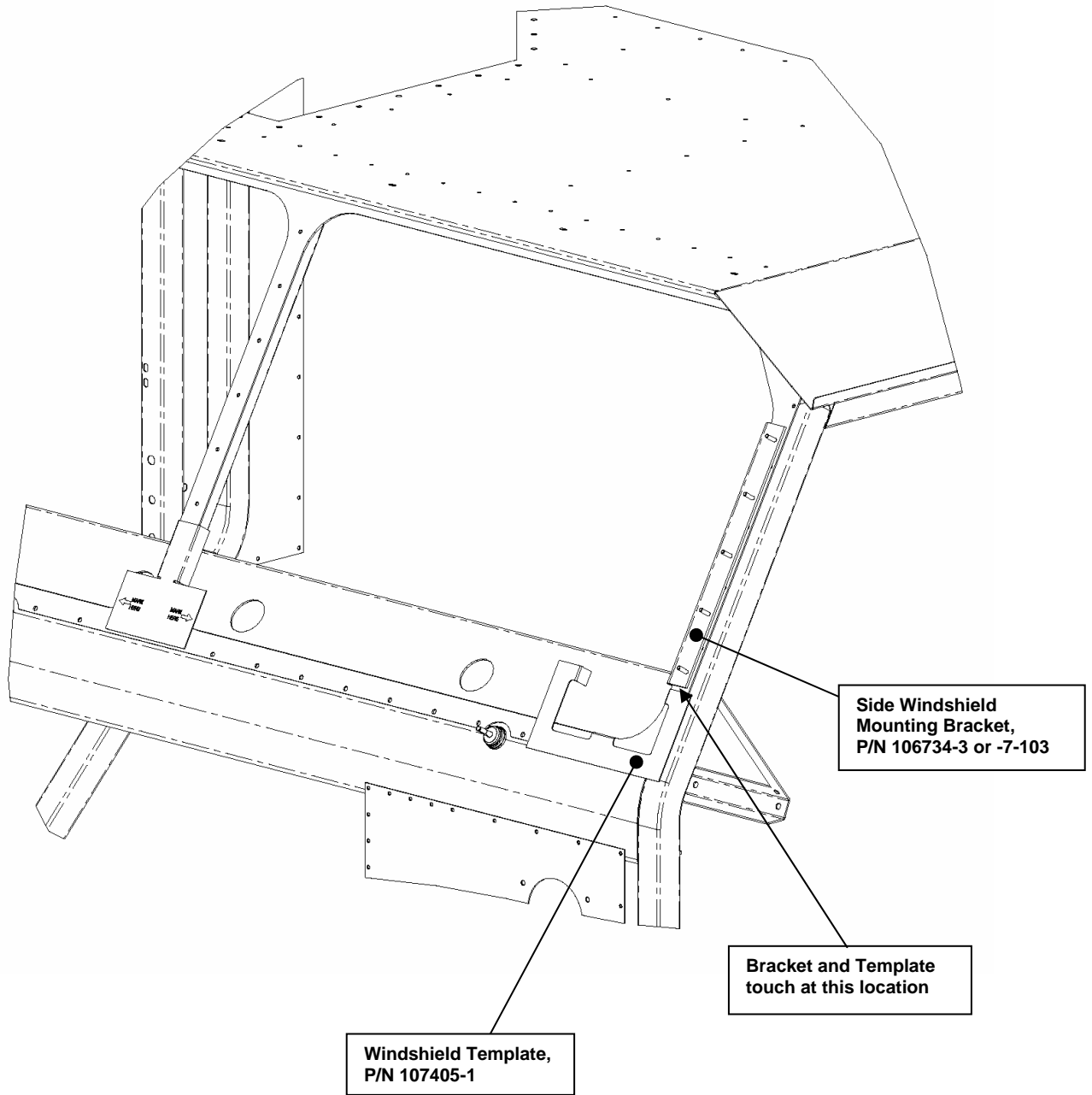

Figure 15. Windshield Bracket, Side Mounting.

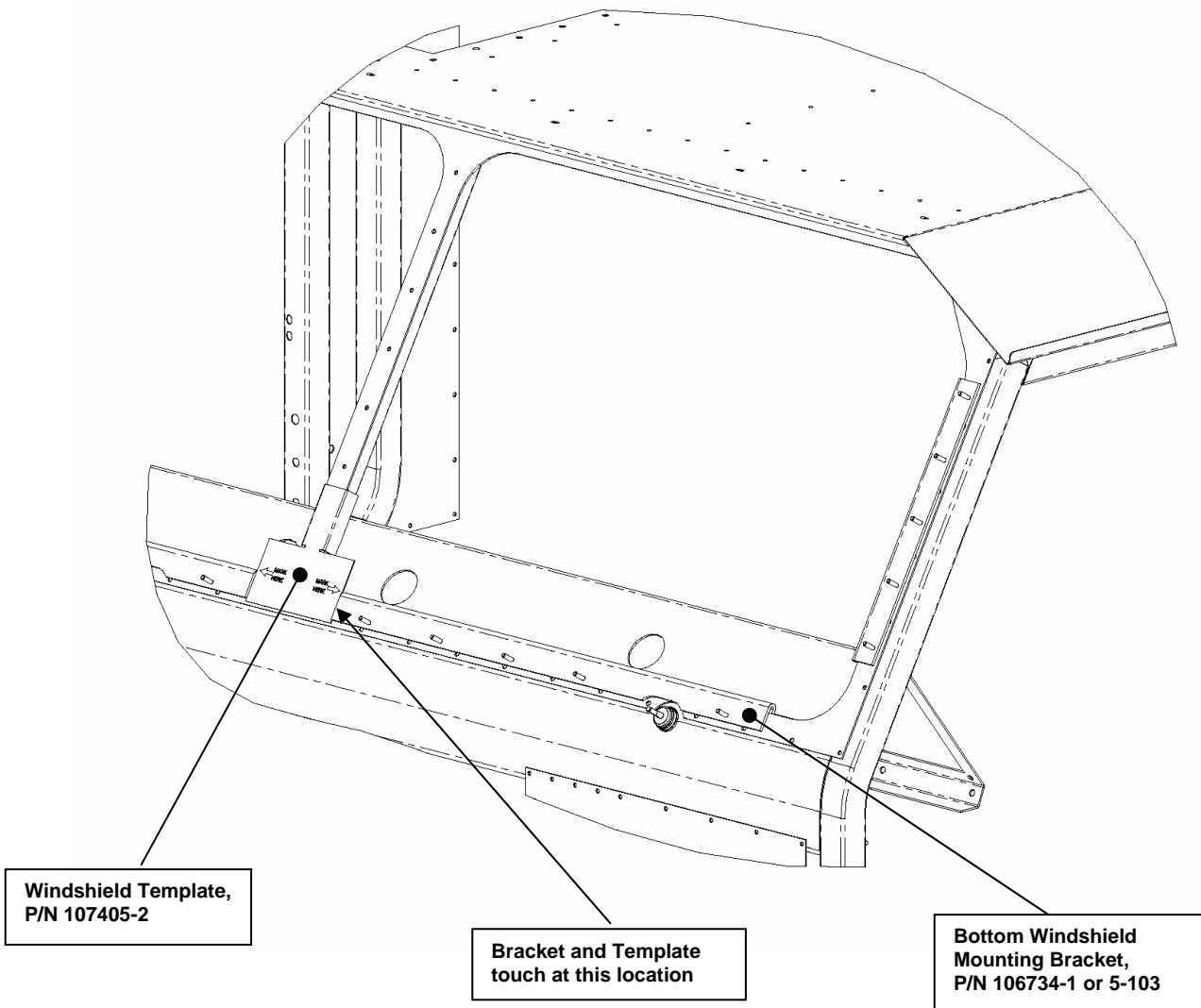

Figure 16. Windshield Bracket, Bottom Mounting.

- e. Attach the Top Windshield Brackets (P/N 106734-2 or -6-103) marked “**This Side Out**” to the **opposite** side of the Windshield Frame (P/N 106721-1-103) on the upper studs using twelve (12) 0.250-in. self-locking nuts and washers (see Figure 17). Verify that both brackets are parallel with the top edge of the windshield frame.
- f. Apply sealant (P/N 104302-1) to the windshield frame around the windshield stud plate mounting holes per Figure 17.
- g. Attach the Windshield Stud Plate, (P/N 106733-1-103) to the Windshield Frame using five (5) 0.250-in. self-locking screws and washers, as shown in Figure 18. Torque the nuts to 6 ft-lb.

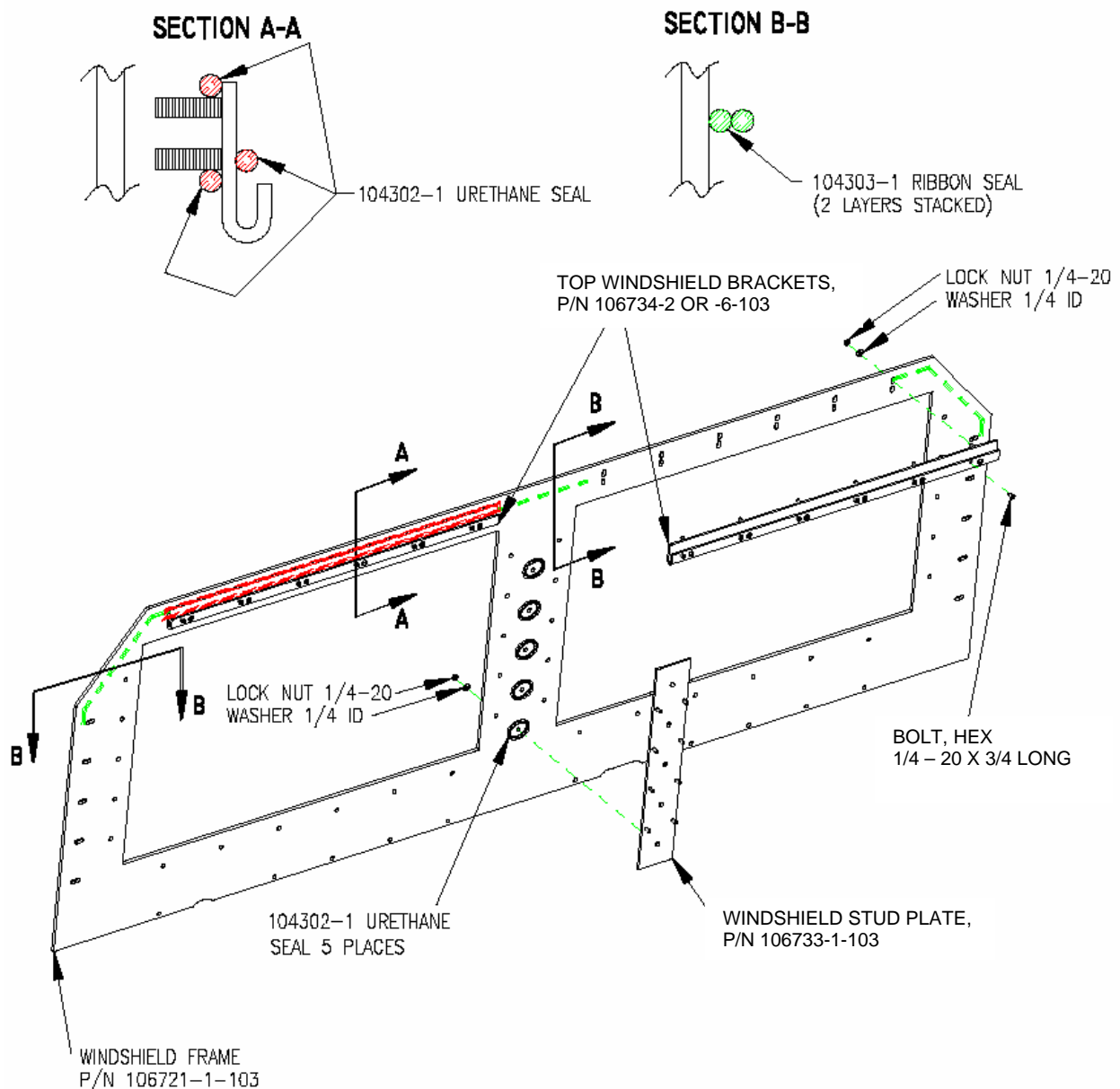

Figure 17. Windshield Frame pre-assembly.

- h. Pre-fit the Windshield Frame Assembly on the vehicle, as shown in Figure 18. Adjust the Side and Bottom Brackets as needed to line up the studs on the Windshield Frame. Use caution to avoid damage to the studs. DO NOT hammer the studs into position on the brackets. Remove the Windshield Frame Assembly and tighten the set screws in the Side and Bottom Windshield Brackets.



Figure 18. Position the Windshield Armor Frame into the cab windshield opening.

- k. To create an environmental seal between the Vehicle Cab and Windshield Frame apply the Urethane Sealant (P/N 104302-1) and the Ribbon Sealer (P/N 104303-1) as shown in Figure 19. If required, use additional sealant from the Front and Side Armor Kits.
- m. Attach the Windshield Frame Assembly to the vehicle as previously done in Step (g) using thirty-six (36) 0.250-in. self-locking nuts and thirty-six (36) 0.250-in. ID washers. Apply light oil to the studs prior to installation of the nuts. Torque to 6 ft-lb.
- n. From the inside of the cab, tighten the Set Screws on the Top Windshield Brackets (P/N 106734-2 or -6-103).
- p. Install the “L” Brackets (P/N 106746-1-103) using the fasteners, as shown in Figure 20. Apply light oil to the studs prior to installation of the nuts. Torque to 6 ft-lb.

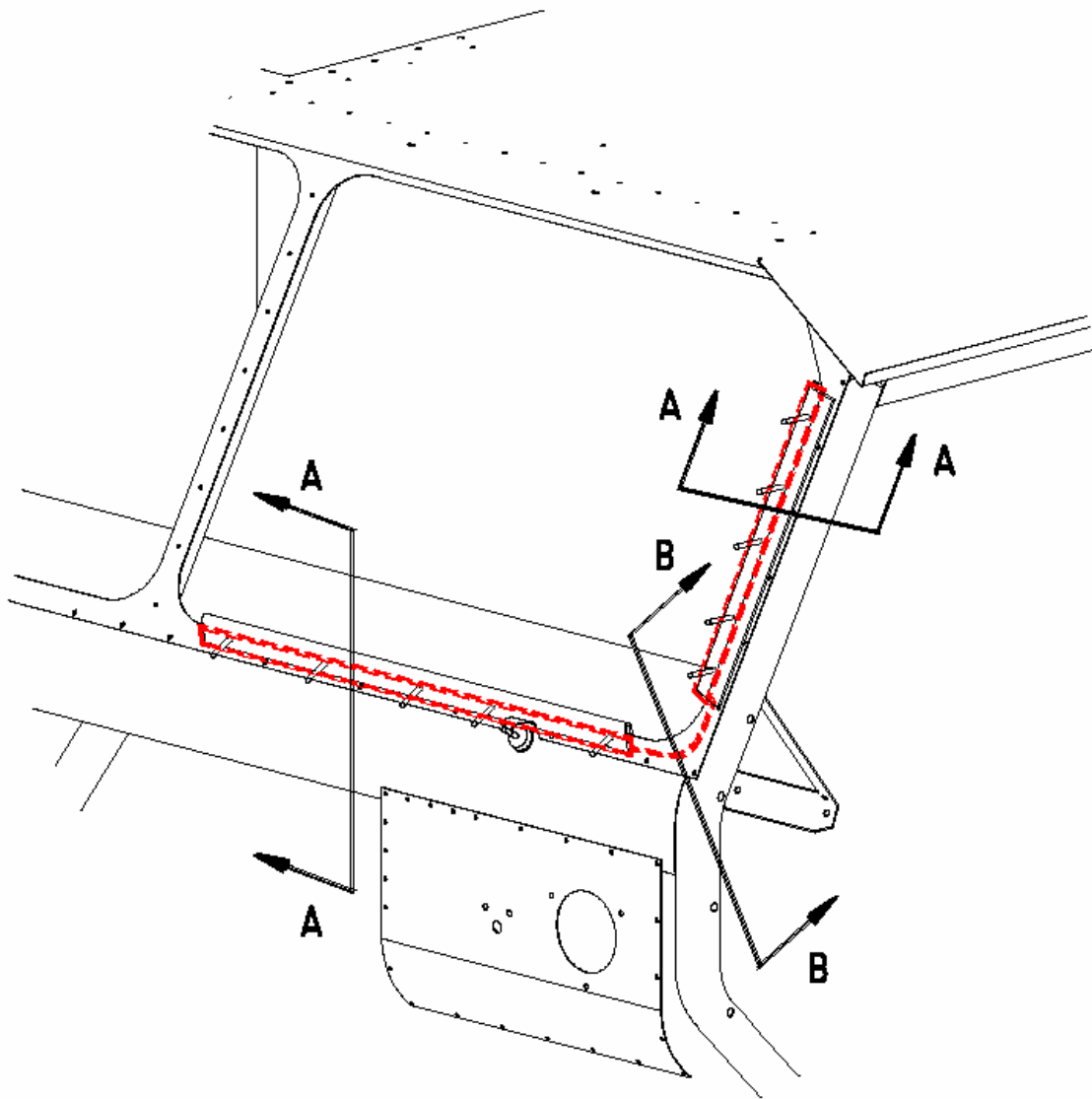
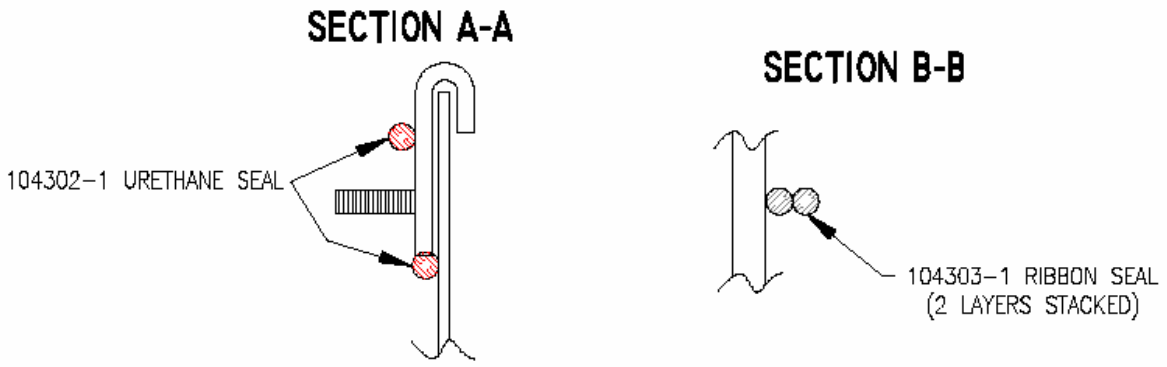

Figure 19. Urethane Sealant and Ribbon Sealer vehicle locations.

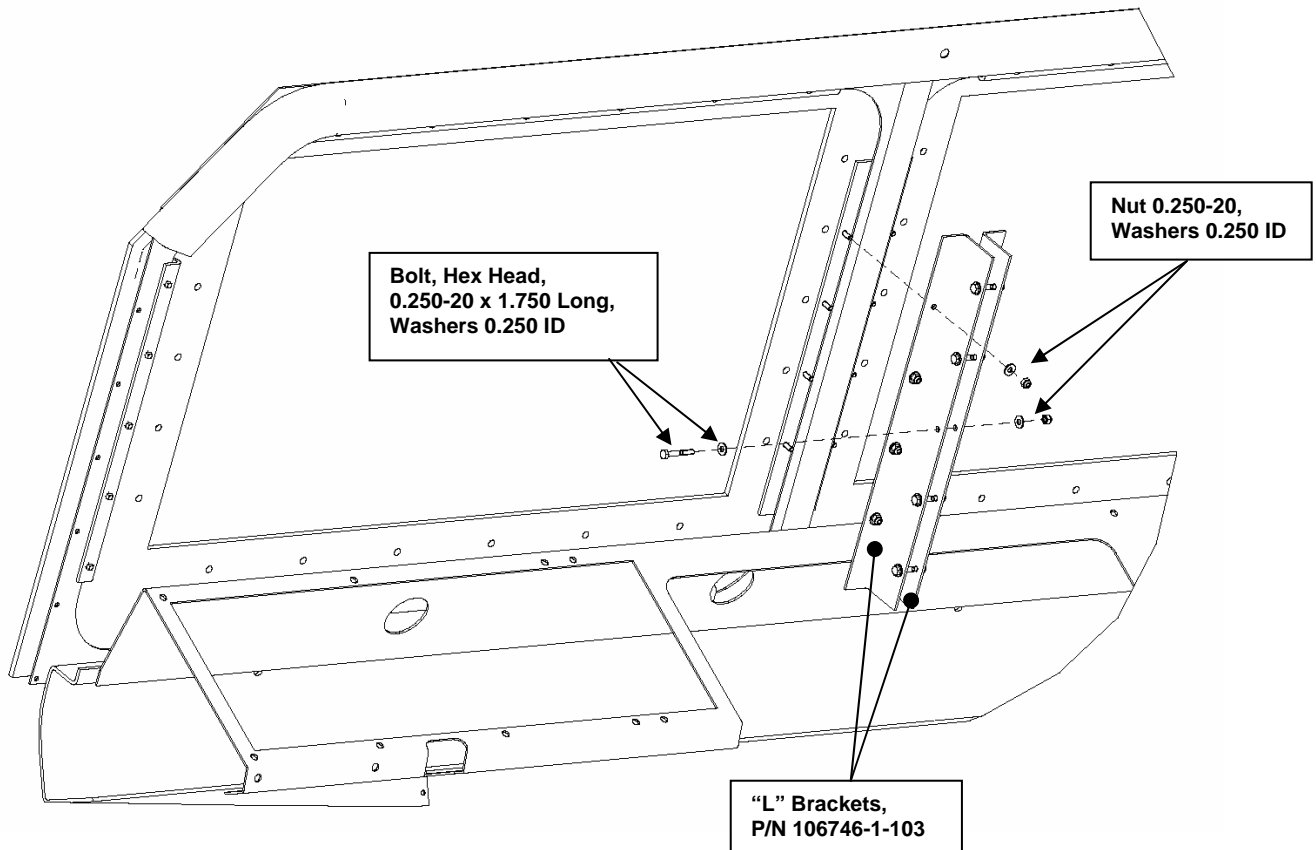

Figure 20. "L" Bracket Installation.

- r. Apply Urethane Sealant (P/N 104302-1) to the outside of the Windshield Frame (P/N 106721-1-103), as shown in Figure 21. This will provide a seal around the Windshield Armor (Glass) (P/N 113381-1) once it is installed.

WARNING

FOR PROPER THREAT PROTECTION, THE TRANSPARENT WINDSHIELD MUST BE CORRECTLY INSTALLED. ENSURE THAT THE STENCIL MARKING "INSIDE OF VEHICLE" IS LOCATED SO THAT THE IDENTIFIED SURFACE IS FACING THE INSIDE OF THE CAB. IMPROPERLY INSTALLED WINDSHIELD ARMOR WILL NOT PERFORM AS INTENDED AND MAY RESULT IN INJURY OR LOSS OF LIFE.

WARNING

DO NOT WIPE OR SPRAY THE WINDSHIELD WITH ANY CHEMICALS OTHER THAN ISOPROPYL ALCOHOL (USED TO CLEAN IT). OTHER CHEMICALS CAN DAMAGE THE WINDSHIELD ARMOR TO THE EXTENT THAT THE ARMOR WILL NOT PERFORM AS INTENDED AND MAY RESULT IN INJURY OR LOSS OF LIFE (I.E., HARSH CHEMICALS SUCH AS CLEANING AGENTS OR INSECTICIDES MAY CAUSE THE BALLISTIC WINDSHIELD TO WEAKEN / CRACK.)

- s. Loosely attach the two lower Windshield Retaining Brackets (P/N 113383-1-103) using 0.250-in fasteners to the Windshield frame, see Figure 21. Set the Windshield Armor (P/N 113381-1) on the Retaining Brackets and over the openings of the Windshield Frame (P/N 106721-1). Complete the installation by securing the Windshield Armor in place, using the remaining Windshield Retaining Brackets (P/Ns 113383-1-103 and 113383-3-103), and tightening all the 0.250-in. fasteners, as shown in Figure 21.

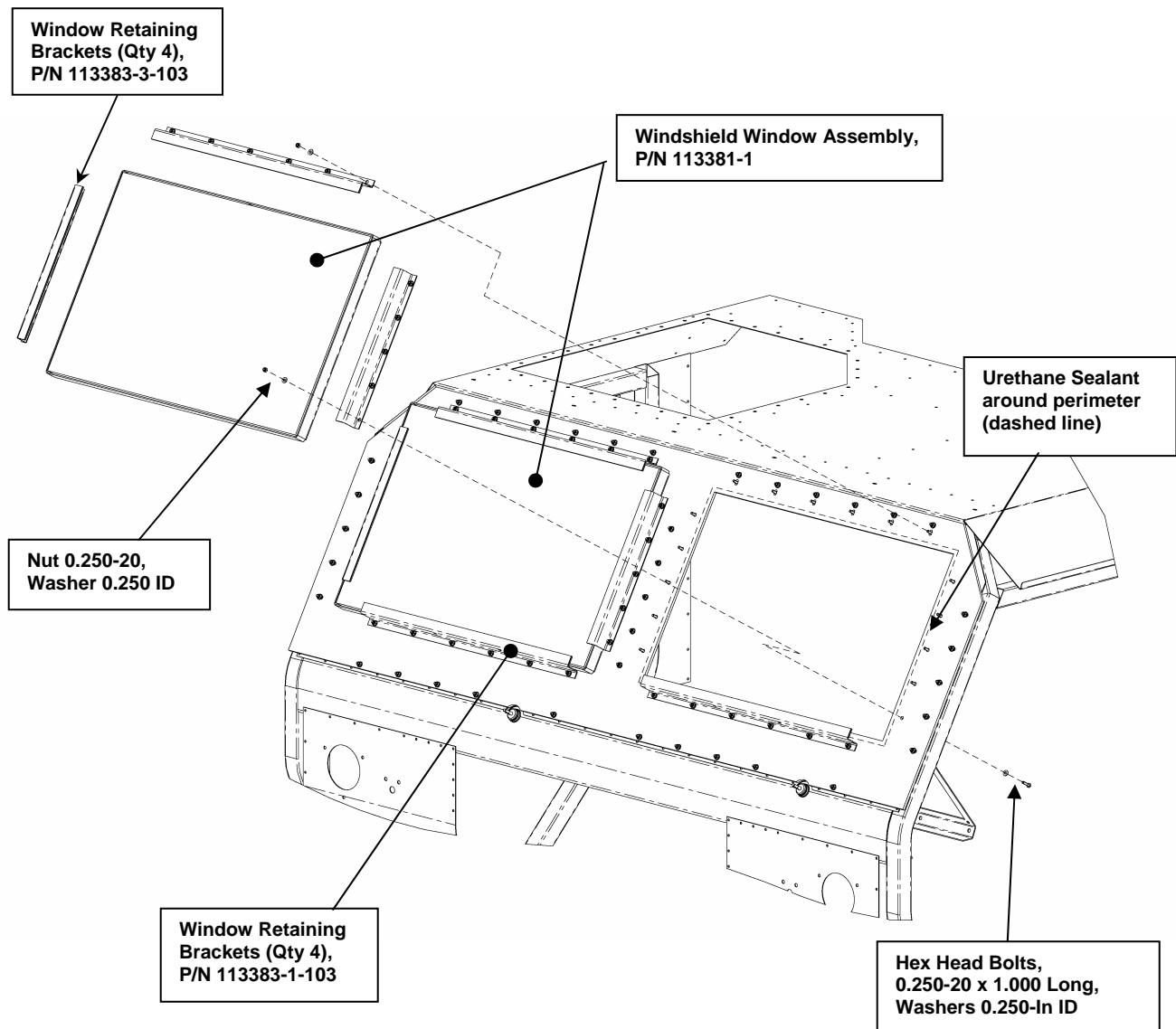

Figure 21. Armor Windshield installation.

- t. If this is the first time the Windshield Armor has been installed on a vehicle, apply the Cleaning Decal (P/N 104301-1) to the lower left hand corner of the Windshield Armor (see Figure 22) so that it does not obstruct the driver's / passenger's view. Remove the protective covers from the transparencies.

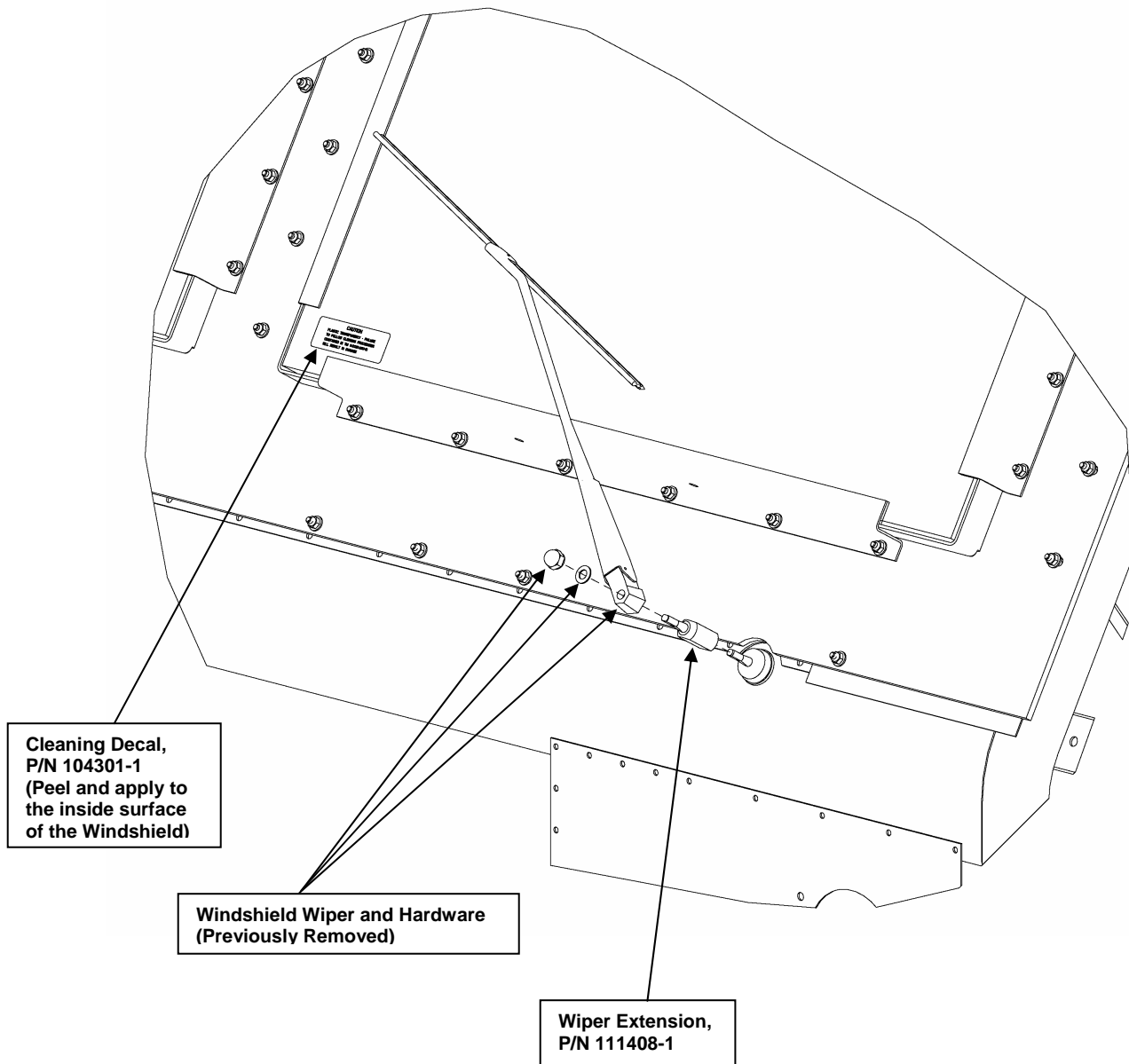

Figure 22. Windshield Wiper and Cleaning Decal installation.

- u. Install the Wiper Extension (P/N 111408-3) by threading the part fully onto the wiper shaft and locking it in place using the set screw located on the side of the Wiper Extension (see Figure 22). Re-attach the Windshield Wiper and Hardware that was previously removed. Reconnect the wiper fluid hose to its nodule. Adjust the wiper as necessary for correct arm travel.
- v. It is recommended that a leak check of the windshield be performed prior to returning the vehicle to service.

5.1.2 Install the Front Armor Protection Kit, P/N 106705-3

- a. Install the LH and RH Seven-Wire Wiring Pigtail (P/N 111438-4) to extend the headlight and marker light wires (plug in).
- b. Insert the Seven-Wire Wiring Pigtail and the attached Grommet into the Headlight Cover (P/N 113379-1) on the LH and RH sides.
- c. Caulk the inside perimeter of the Headlight Covers with sealant (P/N 104302-1 of Kit P/N 106701-4).
- d. Attach the Headlight Covers (LH and RH using three screws (No. 14 - 0.500 LG) for each cover (See Figure 23). Start the screws from inside the cab. The cover's holes are threaded for the No. 14 screw.



Figure 23. Install the Headlight Covers.

- e. Using a lift sling and material handling equipment (hoist, forklift, etc.), position the Lower Brush Guard (P/N 111496-1) over the grille area of the front of the cab, and position the two armor panels (P/N 111426-1) on the Lower Brush Guard, and then attach the items to the cab using eight bolts (3/8 - 16 x 1.500 LG) and eight washers (3/8 in. ID, USS 1 in. OD); four bolts and washers are installed on each side of the Lower Brush Guard. Hand-tighten the eight bolts. Remove the material handling equipment and lift sling from the Lower Brush Guard (See Figure 24).
- f. Install the Upper Brush Guard Installation Guides (studs) (P/N 107430-1 of Kit P/N 106707-1) into the second threaded bolt hole from each outside end of the upper skid plate mounting frame. Hand-tighten the studs in place.

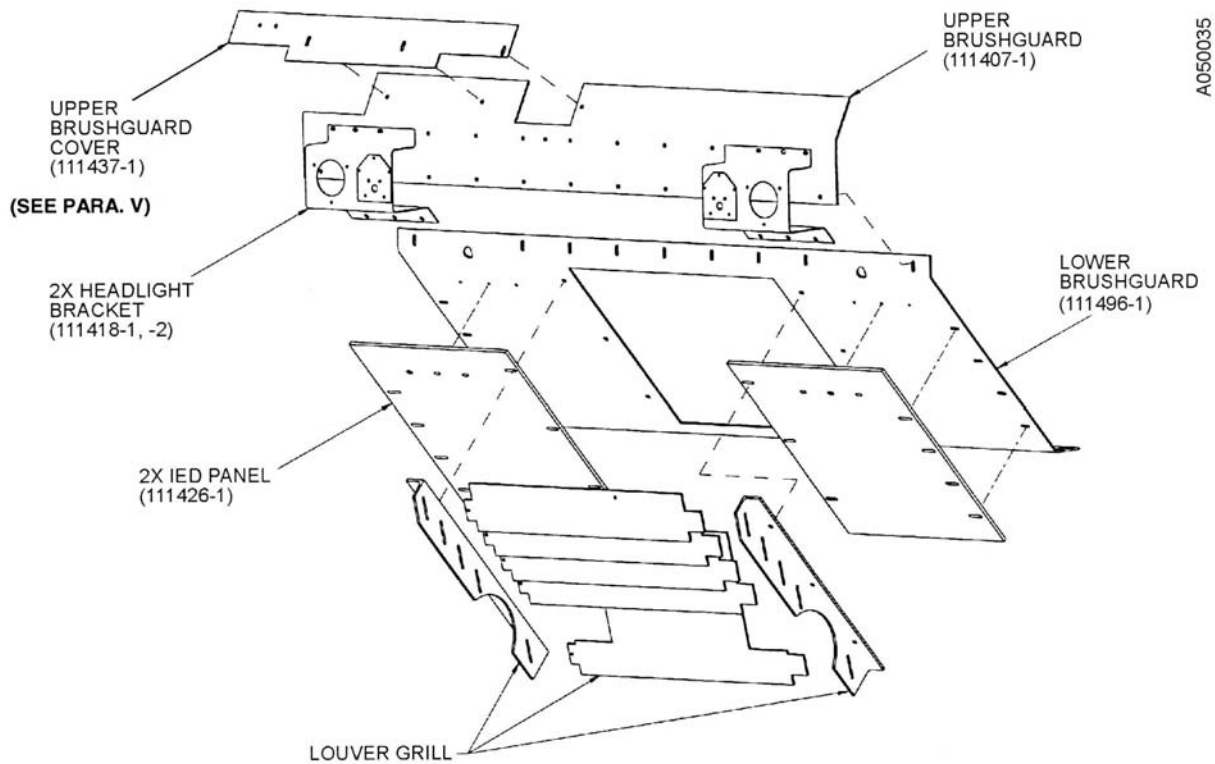

Figure 24. Front HEMTT Armor Kit locations.

- g. Install the Upper Brush Guard Shim (P/N 106759-1) over the Installation Guides.
- h. Feed the LH and RH Wiring Extension Harness through the hole in the Lower Brush Guard.
- k. Using a lift sling and material handling equipment (hoist, forklift, etc.), position the Upper Brush Guard (P/N 111407-1) onto the Installation Guides, over the installed Shim, and over the Lower Brush Guard with the “up” arrow (↑) facing the installer.

NOTE

The first and second bolt holes and the sixth and seventh bolt holes from the passenger-side end of the Upper Brush Guard use two bolts (3/8 - 16 x 4.500 LG), four washers (3/8 ID), and two nuts (3/8 - 16) for proper installation. Hand-tighten the bolts. (See Paragraph 5.1.6 if the vehicle is equipped with a gun ring mount.)

At this time, do not install bolts into the bolt holes over the headlight cutouts on the Upper Brush Guard.

- m. Apply Loctite 242 to five bolts (3/8 – 16 x 1.500 LG).

- n. Secure the Upper Brush Guard (P/N 111407-1) to the HEMTT using five bolts (3/8 – 16 x 1.500 LG) and washers (3/8 ID) (See Figure 25) on the upper portion of the Brush Guard, removing the two Installation Guides (P/N 107430-1) as the bolts are installed. Hand-tighten the bolts. Remove the material handling equipment and lift sling from the Upper Brush Guard.
- p. Adjust and position the Upper and Lower Brush Guards as necessary until the desired position is achieved, and then install 9 bolts (3/8 – 16 x 1.250 LG), 18 flat washers (3/8 ID), and 9 locknuts (3/8 – 16) through the Upper and Lower Brush Guard mating point, between the headlight cutouts. Hand-tighten the nuts.
- r. Verify the proper positioning of the Lower Brush Guard (P/N 111496-1) and the bolt holes at the bottom edge of the Lower Brush Guard under the cab door.
- s. Torque the eight bolts (3/8 – 16 x 1.500 LG), on the Lower Brush Guard sides to 23 ft-lb.
- t. Torque the five bolts (3/8 – 16 x 1.500 LG), on the uppermost portion of the Upper Brush Guard to 23 ft-lb.
- u. Torque the nine locknuts and bolts (3/8 – 16 x 1.500 LG), in the bolt line even with the headlight cutouts, to 35 ft-lb.
- v. Install the Upper Brush Guard Cover (P/N 111437-1) using three bolts (3/8 – 16 x 1.500 LG), six washers (3/8 ID), and three locknuts (3/8 – 16).
(Note: The notched portion is up when the vehicle does not have a gun ring mount.)

5.1.3 Install the Headlights

- a. In order to install the Headlight Assemblies, it is necessary to identify which type of Marker Light is used on the vehicle. Before being removed, the Marker Light was located just inboard of the Headlight. Inspect the Marker Light and determine whether an incandescent bulb (i.e., a common lamp bulb) is used inside the light. If an incandescent bulb is **NOT** found, install the Headlight Assemblies using Steps b, c, e, and f, as the Adapter, P/N 111442-1, is not required. If an incandescent bulb **IS** found, install using Steps b through f.
- b. Install the LH Headlight Bracket (P/N 111418-1) (See Figure 25) using two bolts (3/8 – 16 x 1.500 LG) and four washers (3/8 ID) in the top holes. Then, install three bolts (3/8 – 16 x 1.500 LG), six washers (3/8 ID), and three locknuts (3/8 – 16) in the bottom holes of the Headlight Bracket.



Figure 25. Left-hand Headlight Bracket Installed.

- c. Install the RH headlight bracket (P/N 111418-2) using three bolts (3/8 – 16 x 1.500 LG), six washers (3/8 ID), and three locknuts (3/8 – 16) (See Figure 25). Hand-tighten the locknuts. For the bottom holes, use the three bolts (3/8 – 16 x 1.500 LG), six washers (3/8 ID), and three locknuts (3/8 – 16).
- d. Install the LH and RH Marker Light Adapter (P/N 111442-1) to the rear of the Headlight Brackets using five bolts (1/4 – 20 x 1.000 LG) and five washers (1/4 ID) for each bracket.
- e. Plug the LH and RH headlights and marker lights into the Wiring Extension Harness, matching the wire colors and cable numbers.
- f. Re-install the LH and RH headlights and marker lights in the LH and RH mounting brackets using the previously saved bolts/washers/nuts

5.1.4 Install the Armored Louvered Grille

NOTE

The Louvered Grille Brackets are marked “THIS SIDE TOWARD RADIATOR” and “THIS END UP” for proper installation. Verify that the Louvered Grille Brackets are oriented correctly prior to final assembly.

The installed Louvered Grille Brackets should be positioned to the extreme driver's-side and passenger-side stops prior to securing the attachment hardware.

- a. Install the driver's-side Louvered Grille Bracket (P/N 106772-1 and the passenger-side Louvered Grille Brackets (P/N 106772-2) to the Lower Brush Guard (P/N 111496-1) and Armor Panels (P/N 111426-1) using 6 bolts (3/8 – 16 x 1.750 LG), 12 flat washers (3/8 ID), and 6 locknuts (3/8– 16) (See Figure 25). Tighten the locknuts to 35 ft-lb.

NOTE

The Louvered Grille Panel tabs have arrows (↑) marked on the driver's side for proper installation. Verify that the Louvered Grille panels are oriented correctly with the end that has the bolt hole located on the passenger side of the vehicle.

When installing the Louvered Grille Panels, insert the tabbed end without the bolt hole into the driver's-side Louvered Grille Bracket first and then insert the tab with the bolt hole into the passenger-side Louvered Grille Bracket. When installed properly, the arrows on the Louvered Grille Panel tabs should be vertically aligned.

- b. Install the bottom Louvered Grille Panel (P/N 111457-4) into the bottom slots of the Louvered Grille Brackets.
- c. Install the second-to-last Louvered Grille Panel (P/N 111457-3) into the second-to-last bottom slots of the Louvered Grille Brackets.
- d. Install the third Louvered Grille Panel (P/N 111457-2) into the third-from-the-top slots of the Louvered Grille Brackets.
- e. Install the second Louvered Grille Panel (P/N 111457-2) into the second-from-the-top slots of the Louvered Grille Brackets.
- f. Install the top Louvered Grille Panel (P/N 111457-1) into the top slots of the Louvered Grille Brackets.
- g. Secure the Louvered Grille Panels to the Louvered Grille Brackets by installing five bolts (3/8 – 16 x 1.500 LG), ten flat washers (3/8 ID), and five locknuts (3/8 – 16) through the ends of the passenger-side Louvered Grille Panels. Tighten the locknuts to 35 ft-lb.

5.1.5 Install the Rear Cab Armor Panels – Kit P/N 106702-3

- a. Remove the nut from the Harness Bracket (See Figure 26) and move the spacer to the rear of the Bracket to clear the mounting of the Rear Cab Armor Panel Bracket.
- b. Replace the nut and secure the Harness Bracket.



Figure 26. Move the Harness Bracket to the inside for increased clearance for the Rear Cab Armor Panel Bracket.

- b1. Prior to installation of the armor panels, insert four bolts (1/4 – 20 x 1.000), eight washers (1/4 ID), and four nuts (1/4 -20) through the four optional energy-absorbing seat mounting holes on each armor panel (see Figure 26a for locations). Ensure that the nut is on the outboard side.
- c. Install four Mounting Armor Brackets (P/N 106734) onto the Rear Cab Armor Panel (P/N 106724-3) (See Figure 27) using 12 washers (3/8 ID), 12 washers (1/4 ID), and 12 locknuts (1/4 – 20). Tighten the locknuts finger tight.
- d. Apply Loctite 242 to 12 bolts (1/4 - 20 x 0.750 LG) and install them two turns into the four Mounting Armor Brackets (P/N 106734-4) previously installed on the driver's-side rear cab armor panel.
- d1. Using a bolt (3/8 – 16 x 1.250), washer (3/8 ID), and the nut eye (P/N 106795), secure the nut eye in the 1/2-in. hole in the center of the panel with the nut eye outboard. Once the panel is secured, remove the nut eye and replace it with a washer (3/8 ID) and lock nut (3/8 – 16) from the Extra Fastener Kit. Torque to 35 ft-lb. The nut eye will be used to position the other rear cab armor panel.
- e. Using a lift sling and material handling equipment (hoist, forklift, etc.) position the driver's-side Rear Cab Armor Panel (P/N 106724-3) onto the outside rear of the cab, with the arrow (↑) pointing up and facing the installer, and slide the Mounting Armor Brackets over the rear cab window opening edges (See Figure 28).

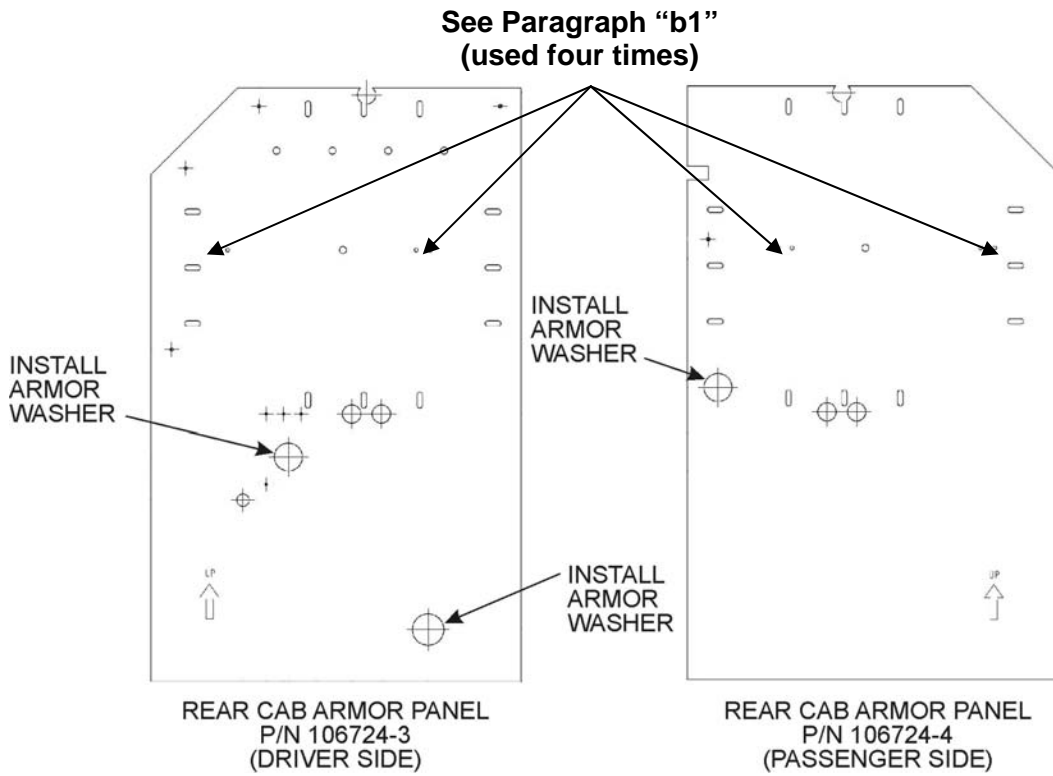

Figure 26a. Armored washer locations.

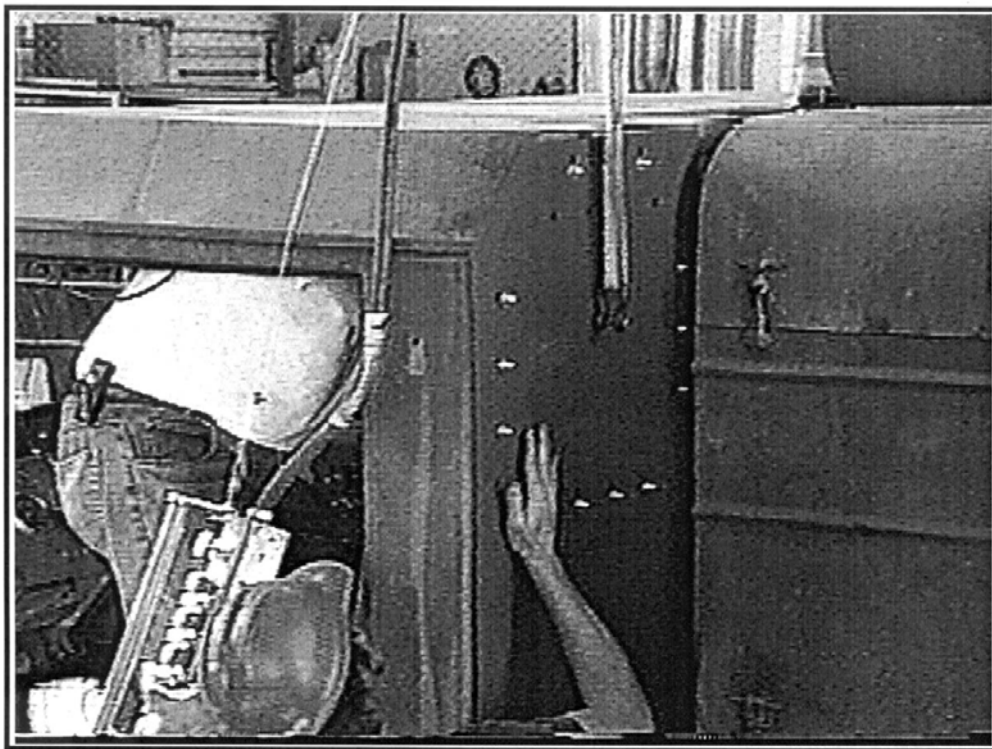

Figure 27. Install Mounting Armor Brackets to the driver's-side rear cab armor panel.

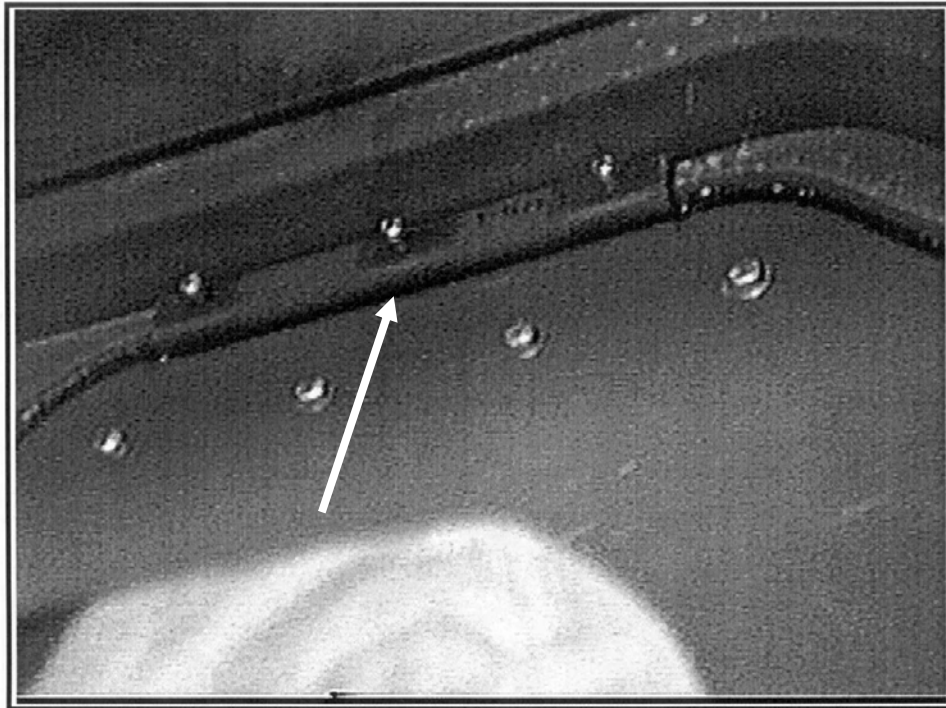
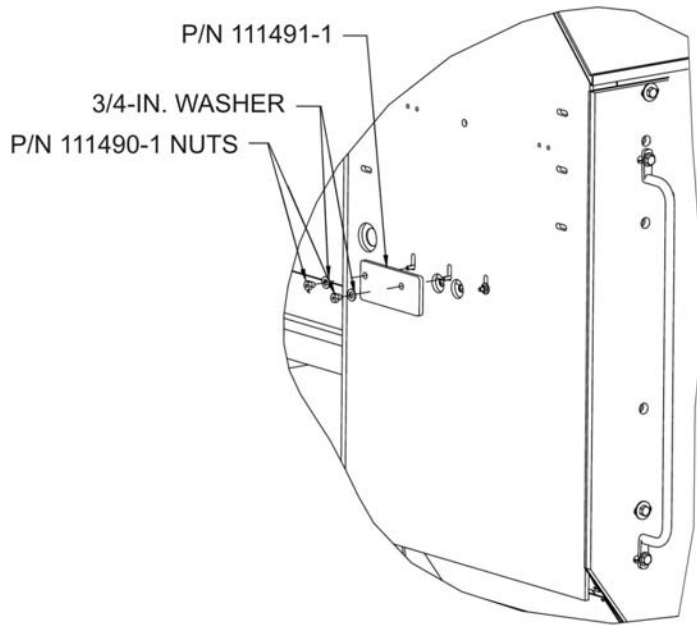

Figure 28. Slide the Mounting Armor Brackets over the rear cab window opening edges.

- f. Adjust the driver's-side Mounting Armor Brackets, as necessary, and tighten the 12 bolts (1/4 – 20 x 0.750 LG) to secure the Mounting Armor Brackets to the cab. Torque the bolts to 9 ft-lb.
- g. Tighten the 12 locknuts (1/4 – 20) that secure the driver's-side Rear Cab Armor Panel to the Mounting Armor Brackets. Torque the locknuts to 9 ft-lb.
- h. Use urethane caulking (P/N 104302-1) to caulk the gap between the driver's-side Rear Cab Armor Panel and the rear cab window opening.
- k. Remove the material handling equipment and lift sling from the driver's-side Rear Cab Armor Panel.
- m. Drill a 1/4-in. Ø hole two places (see Figure 26a) (centered) through the 2.000 and 2.250 Ø holes in the armor panel into the cab.
- n. Drill a 5/16-in. hole using drill guide (P/N 111489-1) through the hole in the rear armor panel (see Figure 28a).
- p. Install bolt (1/4 – 20 x 1.250), armored washer (P/N 111403-1), washer (1/4-in. ID), and self-locking nut (1/4 – 20), with the fender washer on the inside of the cab, in two places (see Figure 26a). If the sound-damping material is in the way, remove it from around the hole.

A050060



Passenger Side

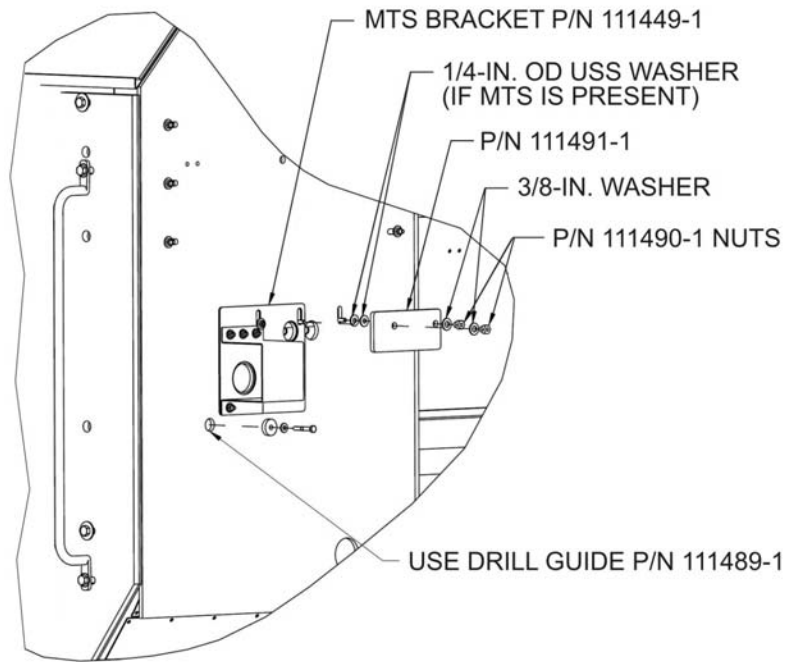

Driver Side

Figure 28a. Armored washer locations.

- r. Insert bolt (1/4 – 20 x 1-3/4 LG) and washers (111403-1, 1/4, GR8, SAE) into the 5/16-in. drilled hole (see Figure 28a) and secure with locknut (1/4 – 20) inside the cab. Torque the fastener to 9 ft-lb.
- s. If the MTS Bracket (P/N 111449-1) has been installed on the driver's side, two washers (1/4 x 1.0 OD, USS) will be required to be used as spacers to install the rectangular armor washer (P/N 111491-1). If the MTS Bracket is not installed, the two spacer washers are not required (see Figure 28a).
- t. Place two spacer washers (1/4 x 1.0 OD, USS) onto the studs protruding from the rear armor panel (Note: Use spacer washers only if the MTS Bracket is installed) (see Figure 28a).
- u. Place the rectangular armor washer (P/N 111491-1) onto the stud and apply Loctite to the stud threads. Secure the rectangular armor washer with two washers (3/8, GR8, SAE) and two nuts (P/N 111490-1). Torque nuts to 4 ft-lb.
- v. Repeat Steps "a" through "u" for the passenger-side Rear Cab Armor Panel (P/N 106724-4), except only one armored washer installation is required (see Figure 26a and 28a) and only one 1/4-in. hole is required to be drilled.

5.1.6 Install the Blast Deflectors, Kit P/N 106706-3 (see Figure 29)

NOTE

HEMTT Armor Kits manufactured after 2004 may include additional mine blast components (Mine Blast Shield, P/N 111458-1, and Radius Block, P/N 111493-1). All assembly instructions are the same for kits with or without the additional components, except as noted in Section 5.1.6, Item c, Step 9.

- a. Install the Driver's-side (LH) Blast Deflector.
 - 1. Remove the drag link from the pitman arm on the steering box to gain access to the fender supports.

A040057

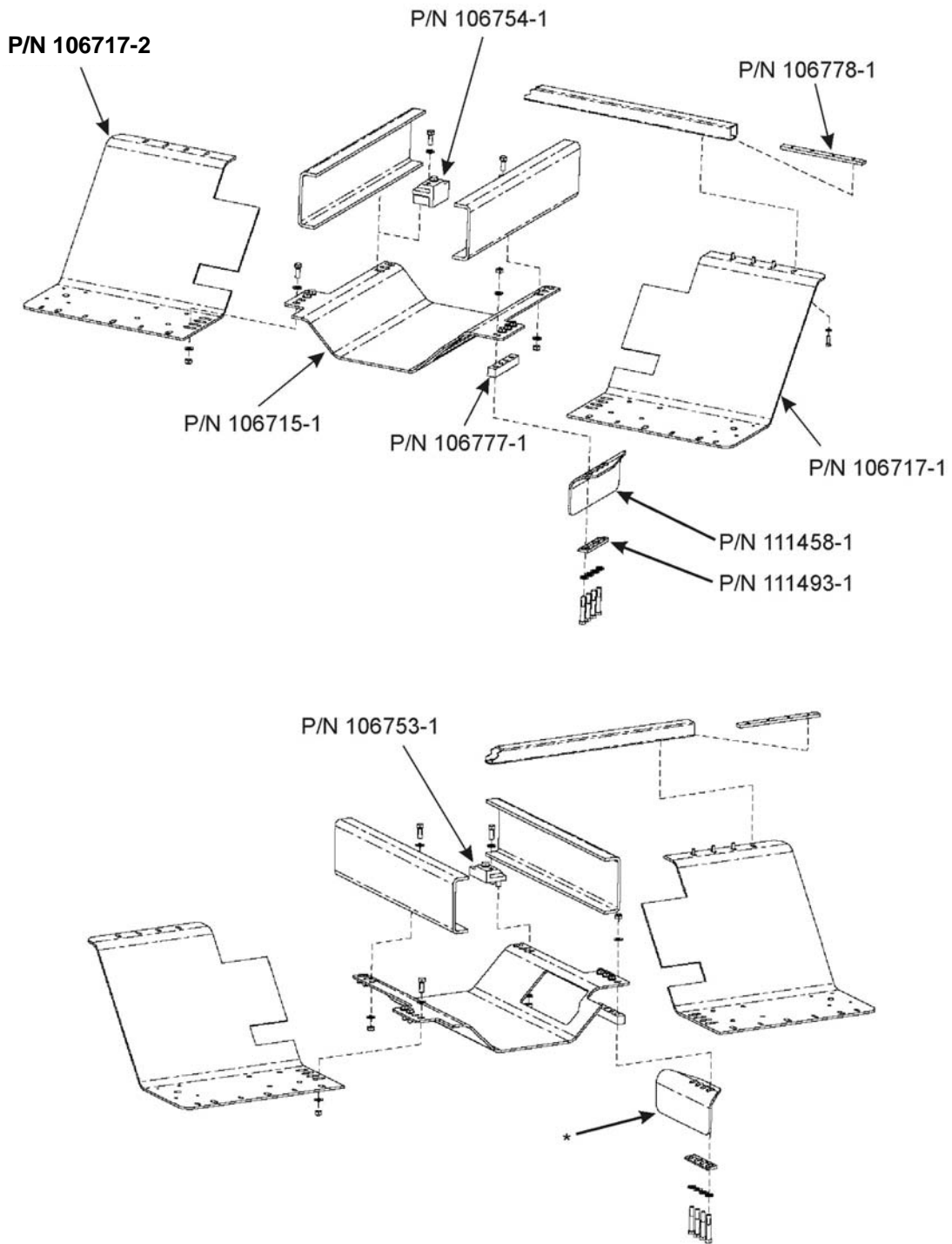

Figure 29. Blast Deflector installation (1 of 2).

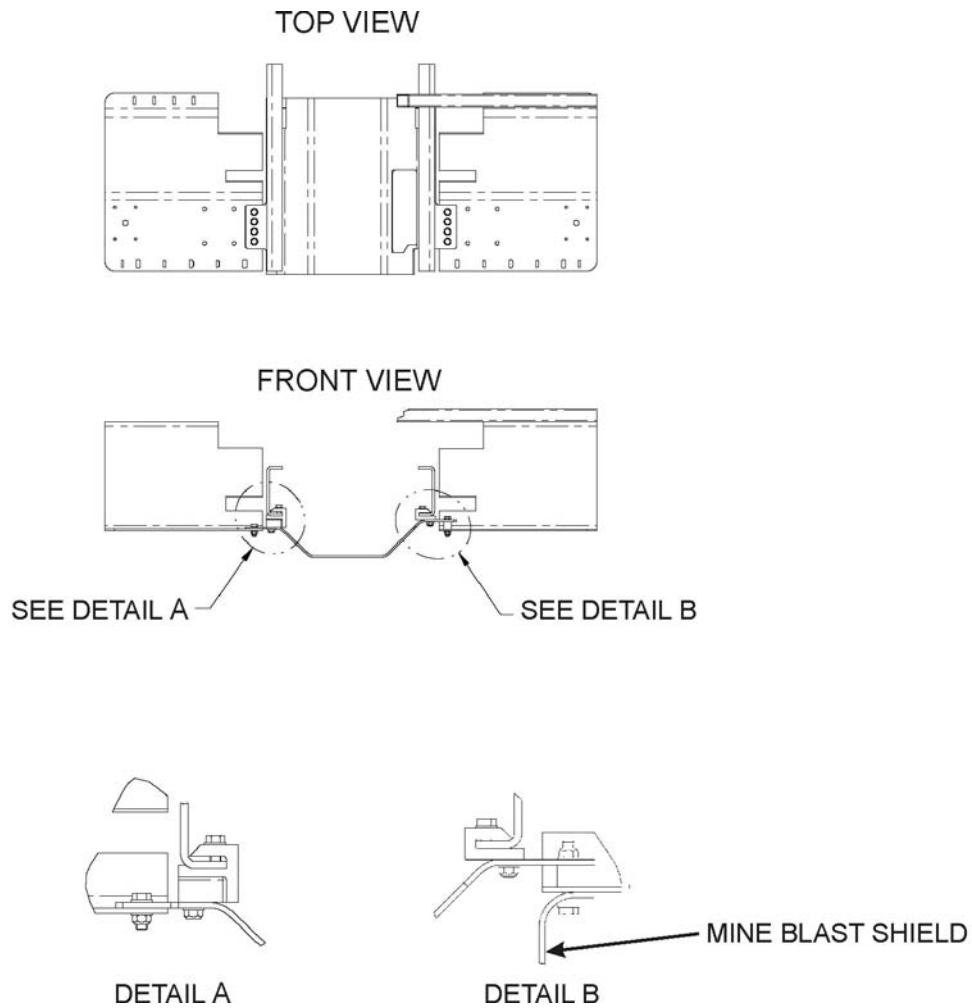

Figure 29. Blast Deflector installation (2 of 2).

CAUTION

Do not move the vehicle while the Drag Link is disconnected. This can result in hole misalignment.

- a. Remove the nut (Item 5 in Figure 29a), washer (6), and screw (7), and spread the slot in the lower end of the pitman arm.

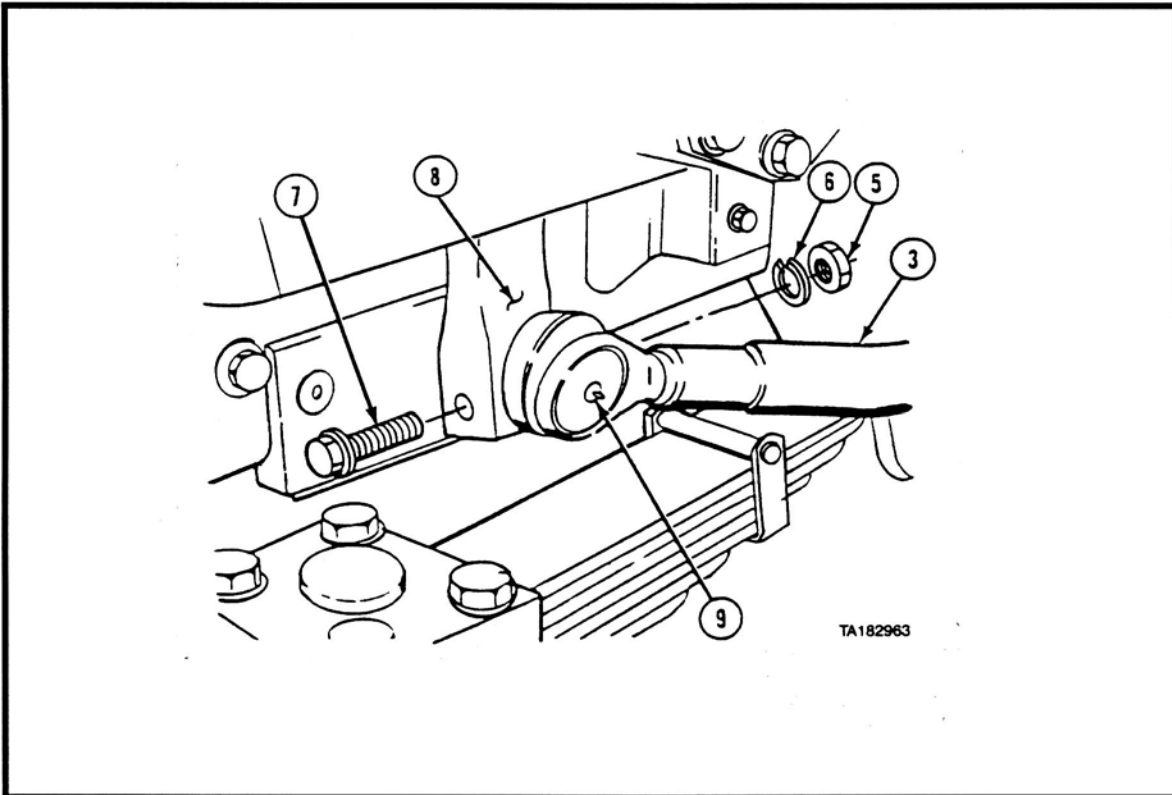

Figure 29a. Remove the drag link from the pitman arm on the steering box.

- b. Disconnect the drag link (3) from the pitman arm (8).
1. Use the drill template (P/N 107406-1) to locate the through-hole locations on the driver's-side fender support behind the cab (see Figure 30).
 2. Mark and center-punch the hole locations and drill four pilot holes through the bottom surface of the driver's-side fender support using a right-angle drill and a 1/4-in. drill bit (See Figure 30a).

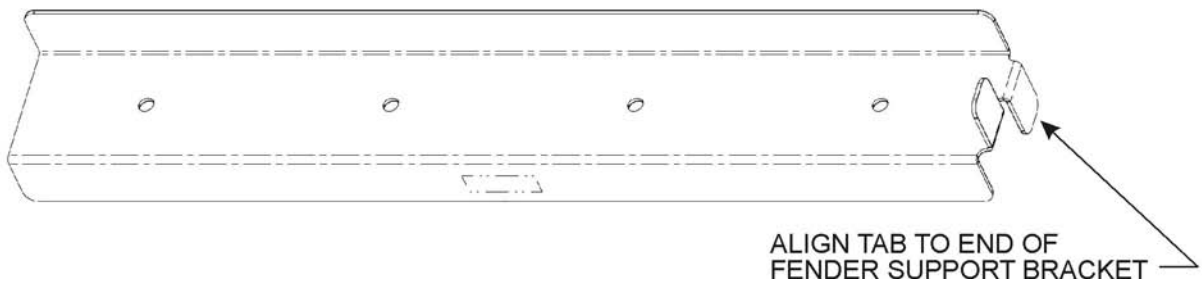

Figure 30. Drill Template (P/N 107406-1).



Figure 30a. Drill the holes for the Front Blast Deflector in the bottom of the fender support.

NOTE

Drill through the bottom of the fender support only. Do not drill through the upper surface of the fender support.

3. Using a right-angle drill and a 3/8-in. drill bit, drill through the 1/4-in. pilot holes previously drilled into the driver's-side fender support. (As an option, the vehicle's front wheels can be removed to access this area.)
4. Using a right-angle drill and a 5/8-in. drill bit, drill through the 3/8-in. pilot holes previously drilled into the driver's-side fender support.

NOTE

Doubler Plates (P/N 106719-1) are installed inside the channel of the brush guard mount, under the cab and over the existing 3.000-in.-diameter holes. The Doubler Plates are put in place to allow the use of attachment bolts on the front of the driver's-side blast deflector and lower brush guard mount. Install the Doubler Plates with the slot aligned for bolt adjustment forward and rearward.

The driver's-side Blast Deflector (P/N 106717-1) cutouts, which are on the inside edge (engine side) of the Blast Deflector, should be positioned over the cab/skid plate frame brace. Make certain that the rear upper cutout is in front of the rear cab mount that is directly behind the cab.

5. Using a suitable lifting device (forklift, jack, etc.) position the driver's-side Blast Deflector (P/N 106717-1) under the cab and secure the forward end to the bottom of the lower brush guard frame using three Doubler Plates (P/N 106719-1), three bolts (0.750 - 10 x 2.500 LG), six flat washers (0.750 ID), three locknuts (0.750 - 10). Install the locknuts finger tight at this time.
 6. Install the Threaded Plate (P/N 106778-1) into the open end of the fender support and align it with the previously drilled bolt holes.
 7. Install four bolts (1/2 - 13 x 1.500 LG) and four flat washers (1/2 ID) through the rear of the driver's-side Blast Deflector and the previously drilled holes in the fender support and into the Nut Plate (P/N 106778-1).
- b. Install the passenger-side Front Blast Deflector, Kit P/N 106706-3.
1. Use the drill template (P/N 107406-1) to locate the four through-hole locations on the passenger-side fender support behind the cab.
 2. Mark and center-punch the four hole locations and then drill four pilot holes through the bottom surface of the passenger-side fender support (See Figure 30a) using a right-angle drill and a 1/4-in. drill bit.

NOTE

Drill through the bottom of the fender support only. Do not drill through the upper surface of the fender support.

3. Using a right-angle drill and a 3/8-in. drill bit, drill through the 1/4-in. pilot holes previously drilled into the passenger-side fender support.
4. Using a right-angle drill and a 9/16-in. drill bit, drill through the 3/8-in. pilot holes previously drilled into the passenger-side fender support.

NOTE

Doubler Plates (P/N 106719-1) are installed inside the channel of the brush guard mount, under the cab and over the existing 3.000-in.-diameter holes. The Doubler Plates are put in place to allow the use of attachment bolts on the front of the passenger-side Blast Deflector and lower brush guard mount. Install the Doubler Plates with the slot aligned for bolt adjustment forward and rearward.

The passenger-side Blast Deflector (P/N 106717-2) cutouts, which are on the inside edge (engine side) of the Blast Deflector, should be positioned over the cab/skid plate frame brace. Make certain that the rear upper cutout is in front of the rear cab mount that is directly behind the cab.

6. Using a suitable lifting device (forklift, jack, etc.) position the passenger-side Blast Deflector (P/N 106717-2) under the cab and secure the forward end to the bottom of the lower brush guard frame using three plates (P/N 106719-1), three bolts (0.750 - 10 x 2.500 LG), six flat washers (0.750 ID), and three locknuts 0.750 – 10). Install the locknuts finger tight at this time.
 7. Install the Threaded Plate (P/N 106778-1) into the open end of the fender support and align it with the previously drilled bolt holes.
 8. Install four bolts (1/2 – 13 x 1.500 LG) and four flat washers (1/2 ID) through the rear of the passenger-side Blast Deflector and the previously drilled holes in the fender support and into the Nut Plate (P/N 106778-1).
- c. Install the Center Blast Deflector, Kit P/N 106706-3.

NOTE

Install all Center Blast Deflector Brackets with the studs facing the ground.

The previously separated steering linkage must be aligned through the cutout on the driver's side of the Center Blast Deflector (P/N 106715-1) during installation.

1. Apply Loctite 242 to four bolts (0.750 – 10 x 2.000 LG) and install the bolts into the driver's-side Center Blast Deflector Bracket (P/N 106753-1) and the passenger-side Center Blast Deflector Bracket (P/N 106754-1). At this time, install the bolts only three turns to allow for adjustment.
2. Install the driver's-side Center Blast Deflector Bracket (P/N 106753-1) onto the frame rail. Install the driver's-side Center Blast Deflector Bracket with the forward surface against the rear edge of the crossmember (see Figure 29).
3. Install the passenger-side Center Blast Deflector Bracket (P/N 106754-1) onto the frame rail. Install the passenger-side Center Blast Deflector Bracket with the forward surface against the rear edge of the crossmember brace (see Figure 29).
4. Torque the four attachment bolts (0.750 – 10 x 2.000 LG) to 280 ft-lb.

NOTE

Install the driver's-side Center Blast Deflector tab (with the bolt holes) on top of the driver's-side Blast Deflector, the spacer (P/N 106777-1) between the Center Blast Deflector tab and the driver's-side Blast Deflector, and the passenger-side Center Blast Deflector tab (with the bolt holes) on the bottom of the passenger-side Blast Deflector. This can be accomplished by twisting the Center Blast Deflector and raising it into place until the driver's-side tab is above the driver's-side blast deflector and then straightening it into the proper position to allow assembly.

The previously separated steering linkage must be aligned through the cutout on the driver's side of the Center Blast Deflector (P/N 106715-1) during installation.

5. Using a floor jack or other suitable lifting device, position the Center Blast Deflector (P/N 106715-1) to the Mounting Bracket Studs (See Figure 31).
6. Secure the Center Blast Deflector to the Mounting Bracket Studs using six flat washers (3/4 ID) and locknuts (3/4 – 10) (See Figure 32).
7. Torque the six locknuts (3/4 – 10) to 280 ft-lb.
8. Install four bolts (3/4 – 10 x 2.000 LG), eight flat washers (0.750 ID), and four locknuts (3/4 – 10) through the matching bolt holes between the inside edge (engine side) of the passenger-side Blast Deflector and the outside edge (passenger side) of the Center Blast Deflector. Hand-tighten the locknuts.
9. Install four bolts (3/4 – 10 x 4.500 LG), eight flat washers (0.750 ID), and four locknuts (3/4 – 10) through the matching bolt holes between the inside edge (engine side) of the driver's-side Blast Deflector and the outside edge (driver's side) of the Center Blast Deflector. Install the Shield, Mineblast (P/N 111458) using the Radius Block (P/N 111493) (on later-model kits where it is supplied) ensuring that the drop-down section is inboard and positioned over the Center Mineblast Shield (P/N 106715) opening. Hand-tighten the locknuts.



Figure 31. Position the Center Blast Deflector onto the Mounting Bracket Studs.

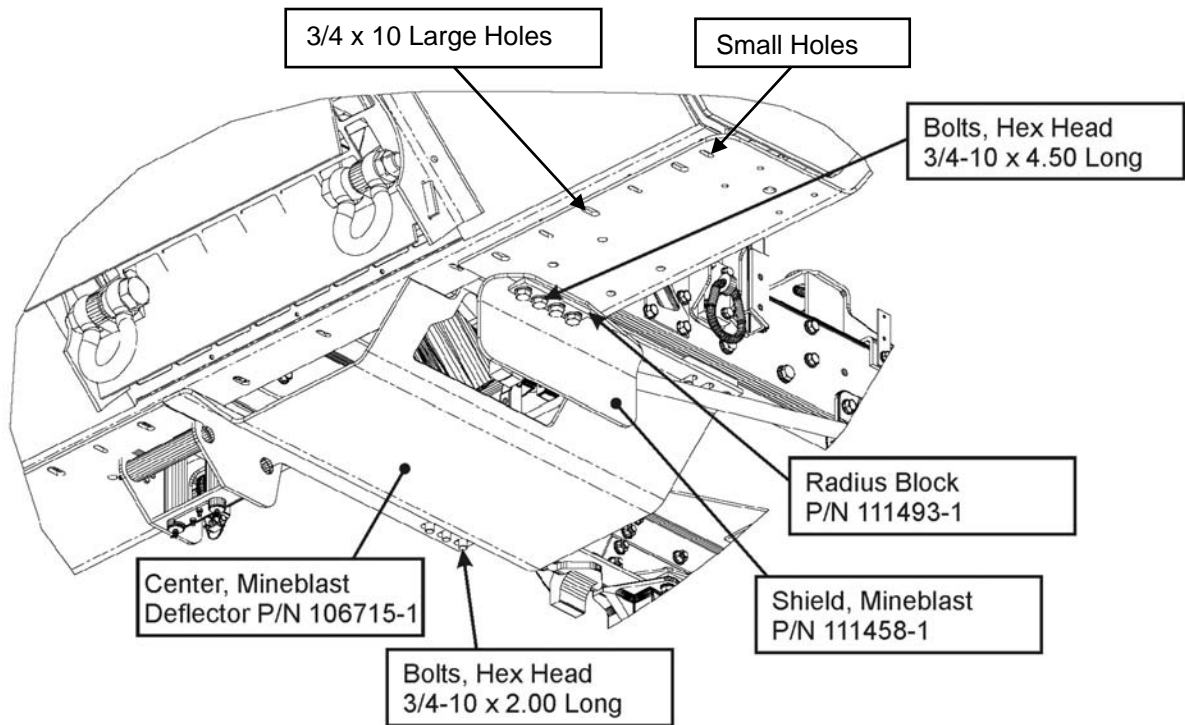

A050006

Figure 32. Secure the Center Blast Deflector to the Mounting Bracket.

10. Torque the eight locknuts (3/4 – 10) to 280 ft-lb.
11. Install three bolts (3/8 - 16 x 1.500 LG), six flat washers (3/8 in. ID, USS 1 in. OD) and three locknuts (3/8 – 16) through the smaller bolt holes in the forward edge of the driver's-side Blast Deflector. Repeat the operation for the passenger-side Blast Deflector (see Figure 32). Hand-tighten the locknuts.
12. Torque the three locknuts (3/8 – 16) to 35 ft-lb, the three locknuts (3/4 – 10) on the forward edge of the driver's-side Blast Deflector to 280 ft-lb, and the eight bolts (1/2 – 13 x 1.500 LG) over the driver's-side rear fender support to 80 ft-lb.
13. Torque the three locknuts (3/8 – 16) to 35 ft-lb, the three locknuts (3/4 – 10) on the forward edge of the passenger-side Blast Deflector to 280 ft-lb, and the eight bolts (1/2 – 13 x 1.500 LG) over the passenger-side rear fender support to 80 ft-lb.
14. Spread the slot in the pitman arm (see Item 1 in Figure 33) and install one end of the drag link (2) into the pitman arm.
15. Install the screw (3), lockwasher (4), and nut (5) through the pitman arm and torque it to 70-80 ft-lb.

CAUTION

Ensure that adequate clearance exists between the draglink adjustment clamp and the Mine Blast Shield (P/N 111458) through the full steering range. Rotate the clamp as necessary to gain adequate clearance.

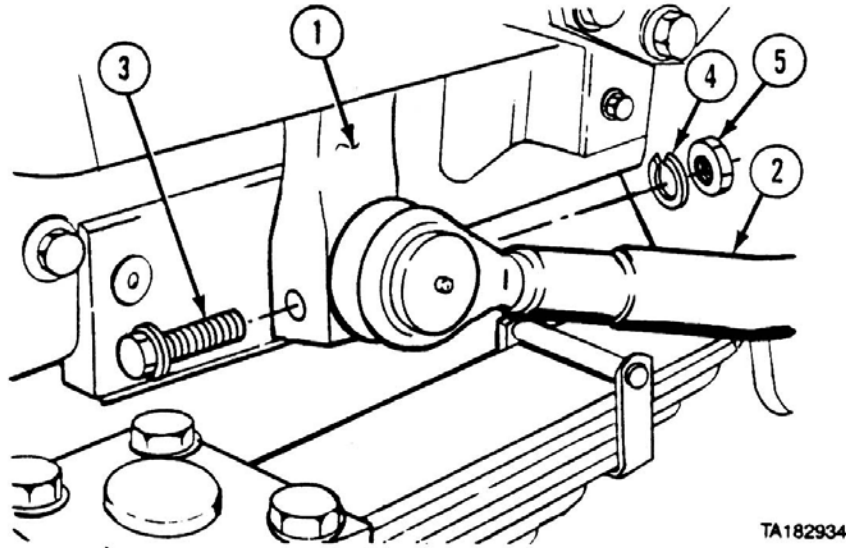

Figure 33. Re-install the drag link.

d. Re-install the Tire Carrier and Spare Tire.

1. Position the Tire Carrier (see Item 1 in Figure 34) on the fender (2).
2. Install two screws (3), two lockwashers (4), and two nuts (5).
3. Install two screws (6), two lockwashers (7), and two nuts (8) on the tire carrier (1) and the fender (2) as shown.
4. Torque the screws (3) to 80 ft-lb.

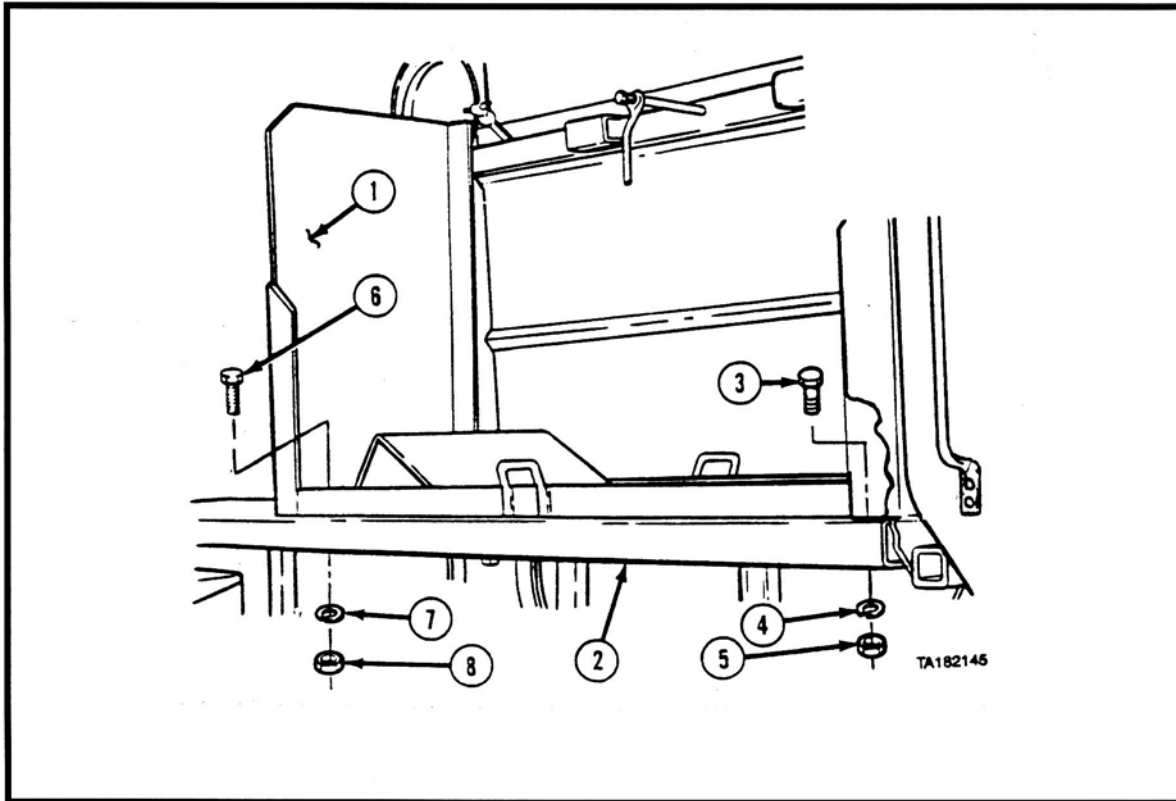

Figure 34. Re-install the Tire Carrier.

5. Torque the screws (6) to 80 ft-lb.
6. Stow the Spare Tire (Per TM 9-2320-279-10).

5.1.7 Re-Install the Cab Steps (with the Internal Clearance Light)

- a. Apply Loctite 242 to four bolts (5/16 – 18 x 1.250 LG).
- b. Position the hard metal cab step onto the bottom surface of the driver's-side Blast Deflector using the four previously prepared bolts (5/16 – 18 x 1.500 LG), eight washers (5/16 ID), and four locknuts (5/16 – 18). Torque the locknuts to 18 ft-lb.

5.1.8 Install the Side Armor, Kit P/N 115500-1 (Driver's Side).

- a. Install the A-Pillar Bracket (P/N 115503) onto the door pillar of the vehicle using nine bolts (5/16 – 18 x 1.500 LG). Torque the bolts to 18 ft-lb (see Figure 35).
- b. Install a lifting strap through the two lifting eyes located at the top corners of the Side Armor Panel assembly.

A050064

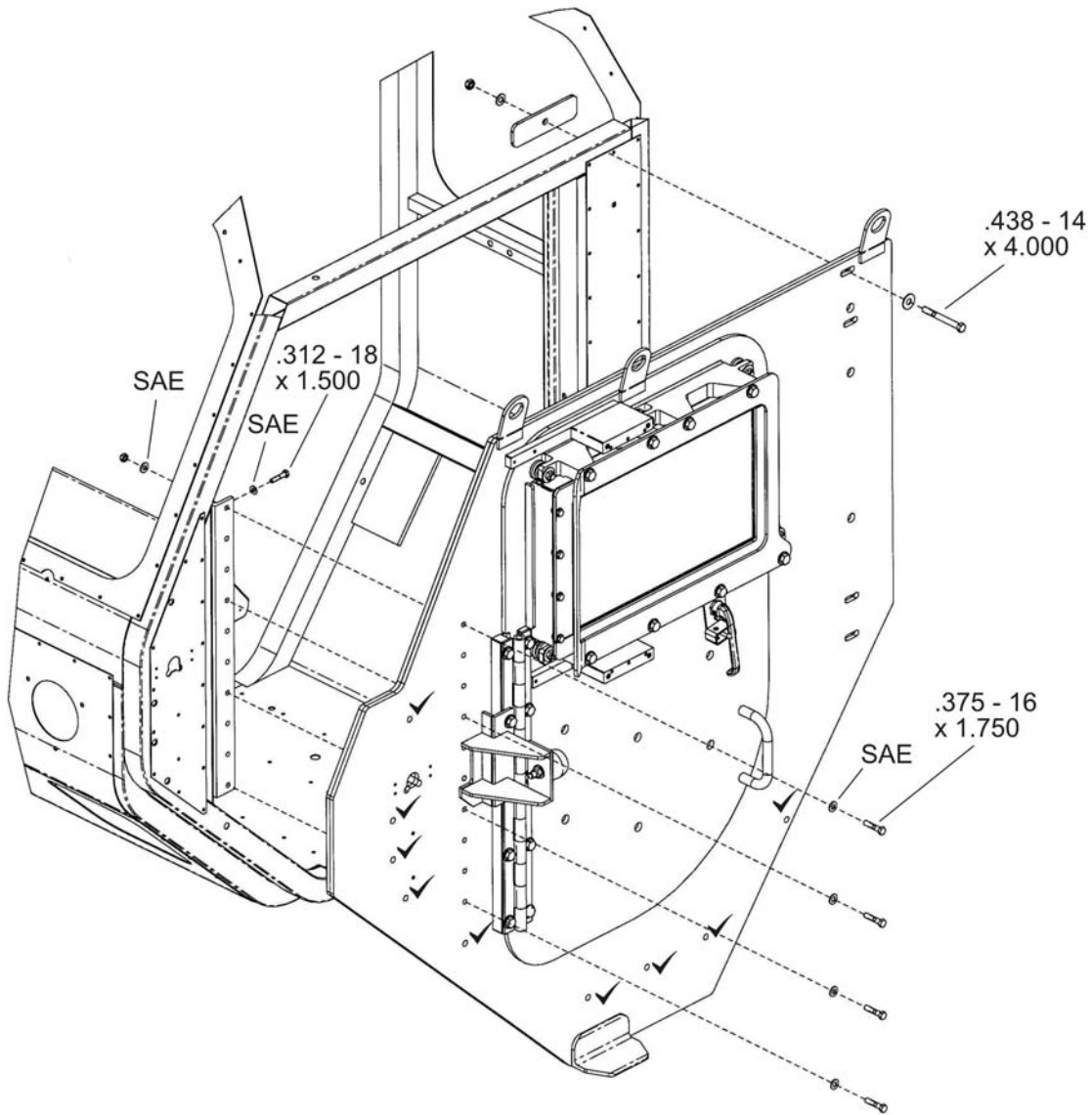

✓ PILOT HOLE LOCATIONS (9)

Figure 35. Temporary Side Armor Panel positioning (showing rivnut pilot hole locations).

CAUTION

DO NOT LIFT THE SIDE ARMOR PANEL ASSEMBLY BY THE DOOR ASSEMBLY'S CENTER LIFTING EYE. DAMAGE TO THE DOOR ASSEMBLY / SIDE ARMOR PANEL ASSEMBLY COULD OCCUR DUE TO THE COMBINED WEIGHT OF THE ASSEMBLIES.

NOTE

The Side Armor Panel, Door Assembly, and numerous hardware items have been pre-assembled at the factory (see the Armor Kit Parts List in Section 4.4).

- c. Using the lifting strap and appropriate material handling equipment (hoist, forklift, etc.), position the Side Armor Panel Weldment onto the door opening and secure the A-Pillar Bracket (P/N 115503) using four bolts (3/8 - 16 x 1.750 LG), eight washers (3/8 ID), and four locknuts (3/8 - 16). One bolt is used at the top of the Bracket, one is used at the bottom of the Bracket, and two are used in the middle of the Bracket.
- d. Secure the right side (upper aft) of the Side Armor Panel using one bolt (7/16 - 14 x 4.000 LG), two washers (7/16 ID), one Attachment Plate (P/N 113316-1), and one locknut (7/16 - 14) (see Figure 35).
- e. Tighten the fasteners, as they provide positions for other fasteners.
- f. Insert a drill bushing into the nine holes [marked with a check () in Figure 35] and match-drill a 3/16-in. pilot hole in each location (see Figure 35).
- g. Remove the fasteners previously installed in Steps "c" and "d" above and remove the Side Armor Panel Assembly from the vehicle using the two lifting eyes, a lifting strap, and appropriate material handling equipment.
- h. Using a drill and a 17/32-in. drill bit, drill through each of the nine 3/16-in. pilot holes.
- k. Install nine rivnuts [3/8 - 16 (AVK)] into the nine 17/32-in. holes (use the Rivnut Installation Tool, see Table 2).
- m. Install the existing clearance light gasket onto the amber clearance light, feed the clearance light wire through the appropriate hole in the Side Armor Panel. Secure the amber clearance light onto the armor panel using four bolts (3/16 - 24 x 1.000 LG) and four washers (1/4 ID) (see Figure 37).
- p. Attach the amber reflector to the Side Armor Panel using two internal hex-head bolts (1/4 - 28 x 0.750 LG) and two washers (1/4 ID).
- r. Feed the amber clearance light wire through the Slit Grommet (P/N 111453-1) and press the Grommet into the hole in the Side Armor Panel. Note: If the Grommet is not already slit, create the slit from the outer edge of the Grommet into the center hole.)
- s. Connect the amber clearance light lead inside the cab using the Extension Pigtail (P/N 111438-3).

- t. Clean the vehicle's tubular frame and install (peel and stick) the Side Seal Gasket (P/N X-103) (Item 14) around the perimeter of the door opening 1/2 in. away from the edge (see Figure 36).
- u. Using the two lifting eyes, a lifting strap, and appropriate material handling equipment, lift the Side Armor Panel into place on the side of the cab and secure it to the previously installed A-Pillar Bracket (P/N 115503-1) using the hardware described in Steps "c" and "d" that was removed in Step "g".
- v. Secure the front and bottom edges of the side Armor Panel using nine bolts (3/8 – 16 x 1.750 LG) threaded into the rivnuts installed in Step "k".
- w. Place the Drill Guide (P/N 111489) into the three 0.75-in.-diameter holes along the rear edge of the panel and drill a 0.31-in. diameter hole through the vehicle cab in each location.
- x. Secure the rear edge of the Side Armor Panel by inserting three bolts (1/4 – 20 UNC x 2.000 LG) and three armor washers (P/N 111403-3), and three washers (1/4 ID, SAE) into the drilled holes and securing them with three washers (1/4 – 1.000 OD, USS) and locknuts (1/4 – 20) inside the cab (see Figure 37).
- y. Reposition the Cab Entry Hand Hold on the second hole from the top of the rear edge of the Side Armor Panel and secure the Hand Hold in place by threading two bolts (7/16 – 14 x 4.000 LG), and two flat washers (7/16 ID) through the hand hold holes and the cab holes and securing them with two Aft Plates (P/N 113316), two flat washers (7/16 ID), and two locknuts (7/16 – 14) on the inside of the cab (see Figure 37). (Optional: If the vehicle uses a two-point seat belt, use two bolts (7/16 – 14 x 4.500), two washers (7/16 ID), and two locknuts (7/16 – 1/4) to fill the holes where the shoulder strap mounts would be located, and use two alternate bolts (3/8 – 16 x 4.750 LG) for the Cab Entry Hand Hold. These bolts are in the extra fastener kit, P/N 111444.
- z. Torque the four locknuts (7/16 – 14) to 35 ft-lb and the three locknuts (1/4 – 20) to 9 ft-lb.
- aa. Attach the Side-View Mirror to the blocks using three bolts (0.250 – 20 x 1.250 LG) and washers (0.250 ID) at the top and three bolts (0.250 – 20 x 1.250 LG) and washers (0.250 ID) at the bottom (see Figure 37).
- bb. If required, adjust the door rotary latch position as follows:
 - 1. Adjust the longitudinal position by removing shims between the latch and the door. Locate the latch so that the striker pin's head is approximately centered in the latch space.
 - 2. Adjust the latch height to match the height of the striker pin. Tighten the screws securely.
 - 3. Adjust the ball joints on the rod to allow the latch mechanism to work properly. Too short – the latch will unlatch too easily. Too long – the latch will not latch smoothly. The length should be just short of "too long". Tighten the jam nuts to lock the rod in place.
- cc. Repeat Steps "a" through "bb" for the Side Armor Kit, P/N 115500-2, (passenger side).

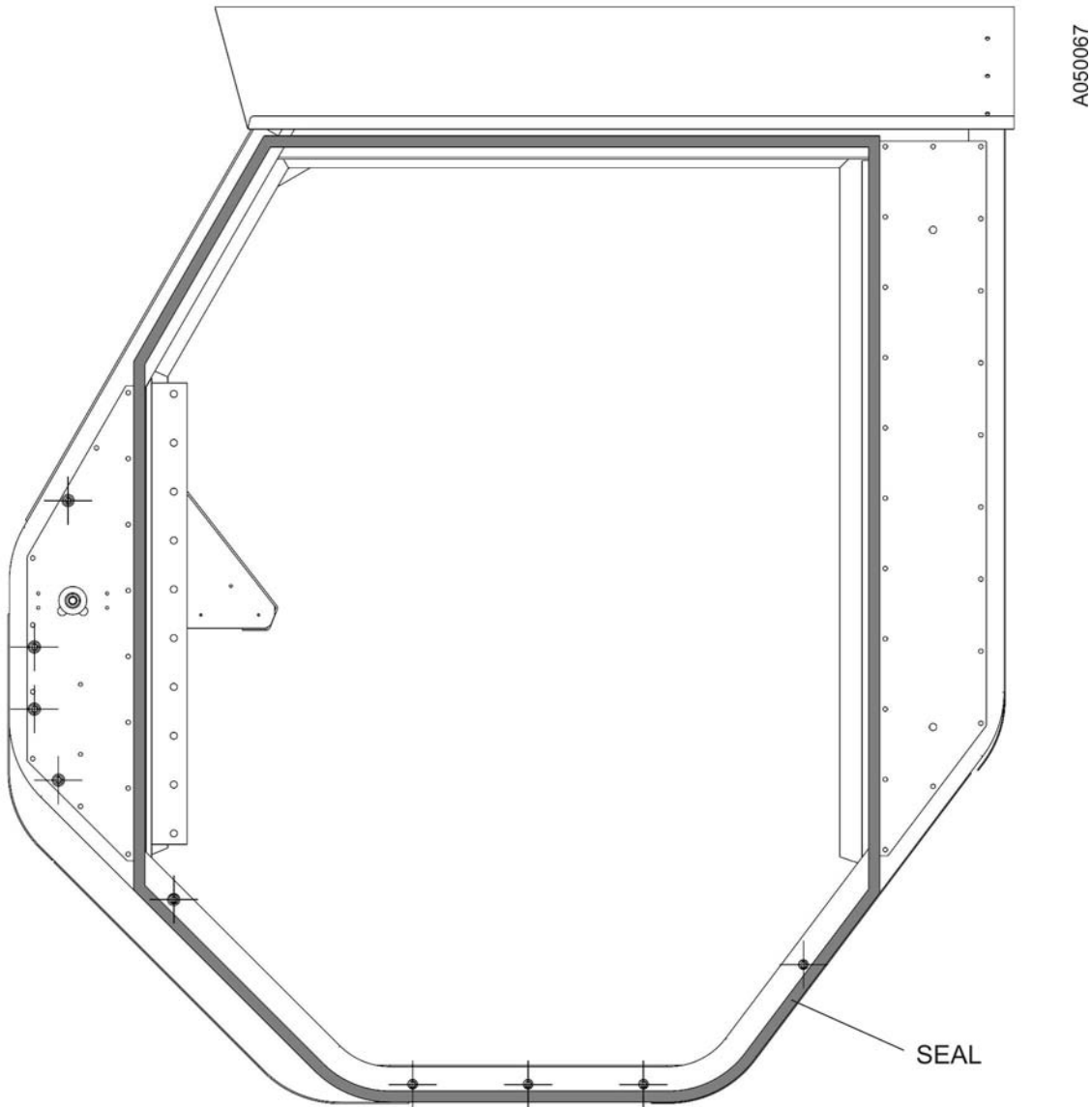

Figure 36. Side Armor Panel Side Seal Gasket attachment.

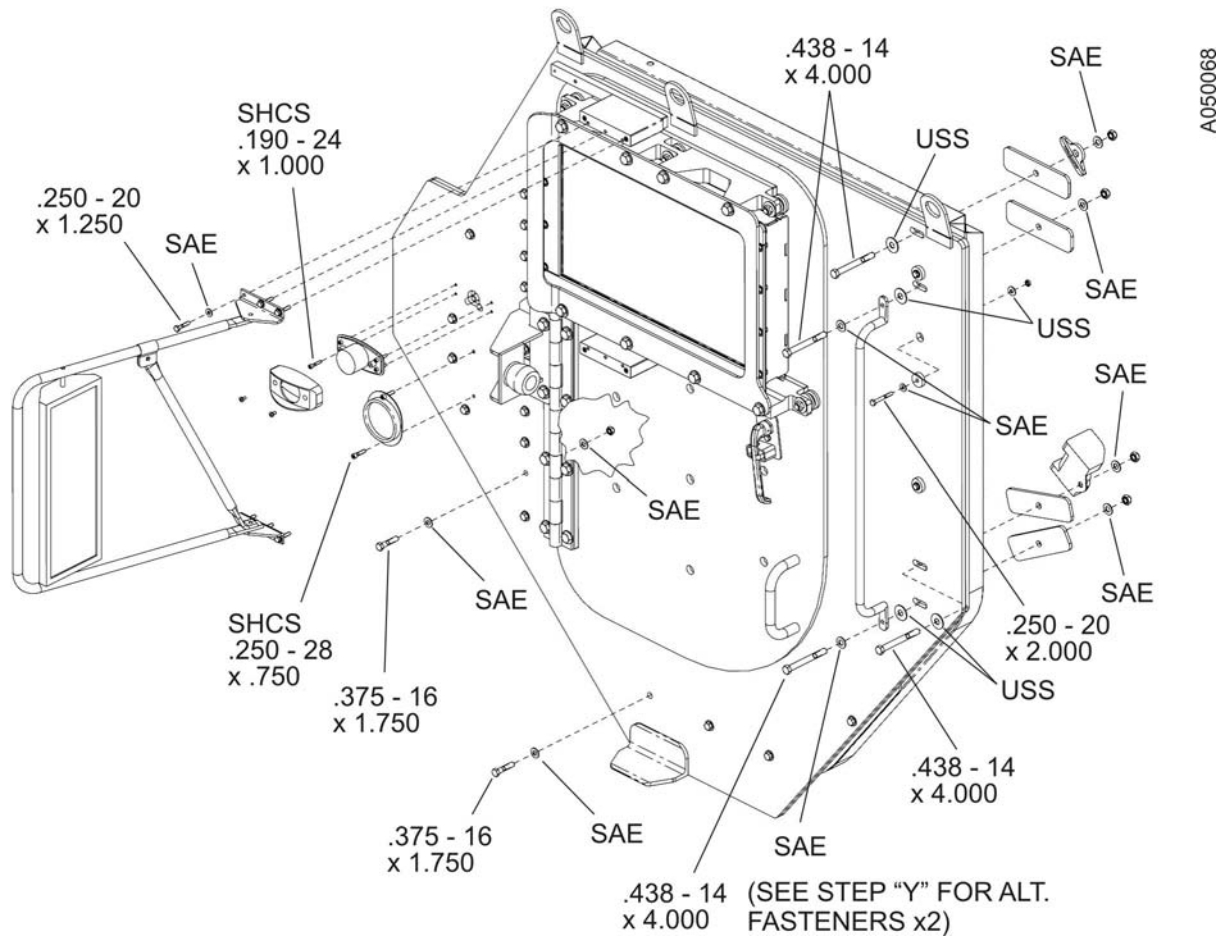

Figure 37. Side Armor Panel Assembly Attachment.

5.1.9 Install the Roof Armor, Kit P/N 106704-3.

NOTE

Install the Front and Rear Studplates (P/N 106780-1 / -2) through the slots in the Roof Armor and then loosely install them using locknuts (3/8 – 16) before lifting the Roof Armor Panel onto the roof of the HEMTT (see Figures 38 and 39).

- a. Install the Escape Hatch Seal (See Figure 40). Align the edge of the seal with the side edge of the roof hatch opening.
- b. Install two Roof Channels (P/N 113347-1) on top of the cab roof using two bolts (1/4 – 20 x 1.000 LG), two washers (1/4 ID), and two locknuts (1/4 – 20) for each channel. These channels serve as a storage platform for the escape hatch (see Figure 40a).

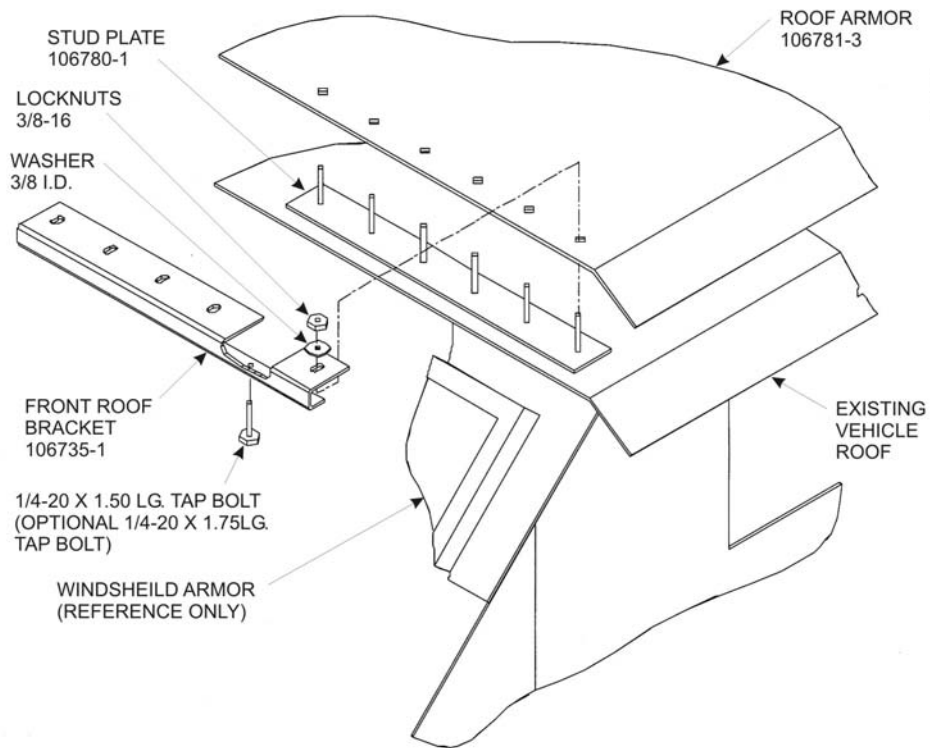

Figure 38. Roof Armor - front driver's-side installation.

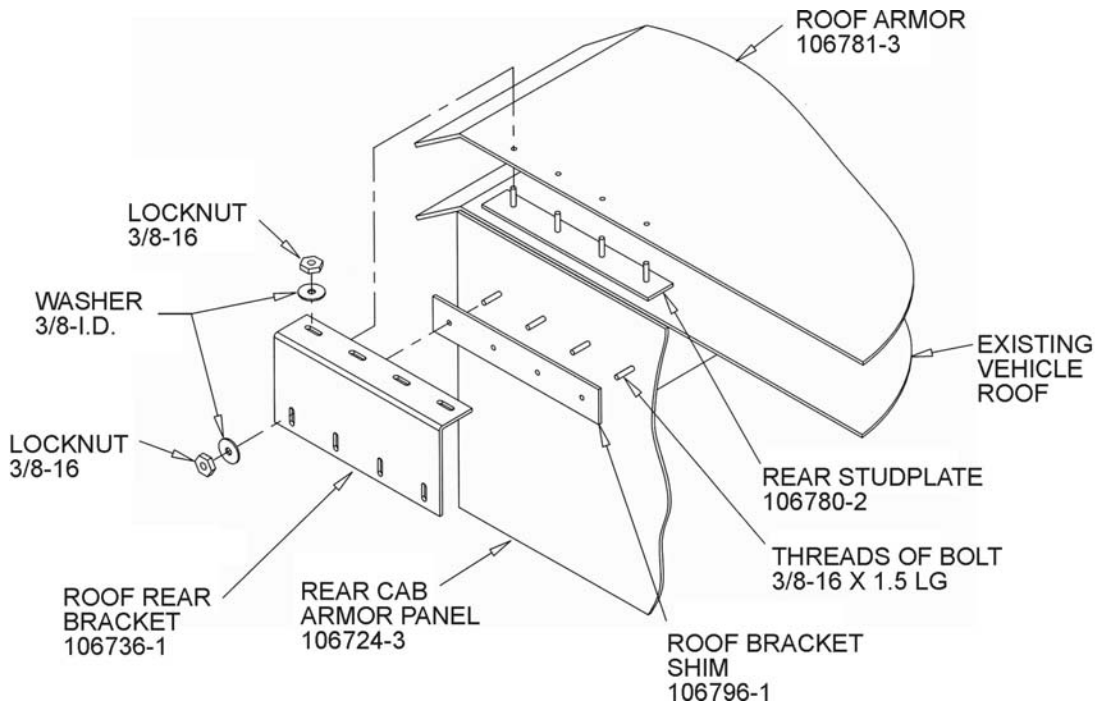

Figure 39. Roof Armor - rear driver's-side installation.



Figure 40. Install the hatch seal.

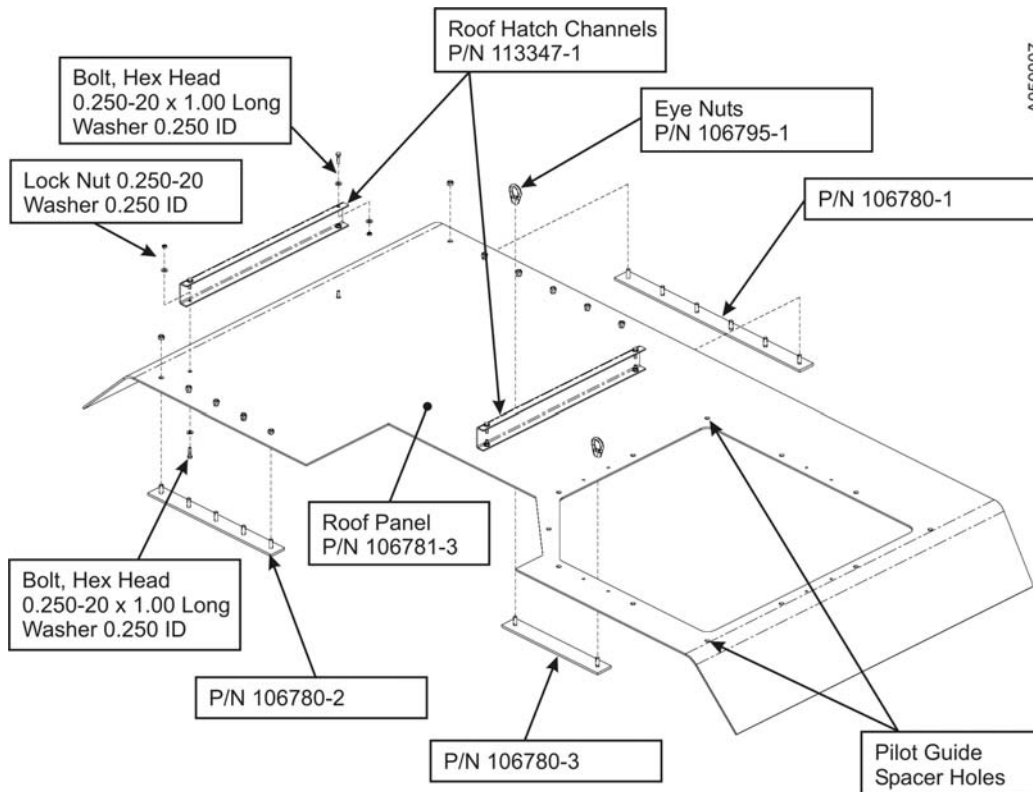

Figure 40a. Roof Armor Assembly hardware installation.

- c. Install the Stud Plate (P/N 106780-3) and two lifting eye nuts (P/N 106795-1).
- d. Install lift straps through the lifting lugs on the Roof Armor Panel (P/N 106781-3) and attach them to the appropriate material handling equipment (hoist, forklift, etc.).
- e. Apply urethane (P/N 104302) around the perimeter underside of the hatch opening prior to lifting the Roof Armor Panel into place on the roof of the HEMTT (See Figure 41).



Figure 41. Lift the Roof Armor Panel into place on the HEMTT roof.

- f. Align the 12 holes in the Roof Armor Panel with the holes in the right-hand side of the roof top.
- g. Remove the lift straps from the material handling equipment and remove the lift straps from the Roof Armor Panel.
- h. Apply Loctite 242 to 10 bolts (5/16 – 18 x 1.250 LG) and 2 bolts (5/16 – 18 x 1.750 LG).
- k. Install two bolts (5/16 – 18 x 1.750 LG), two lockwashers (5/16), two flat washers (5/16 ID), and two spacers through the two holes located on opposite diagonal corners of the Roof Armor Panel hatch opening. These bolts serve as pilot guides for the alignment of the Escape Hatch Cover.

- m. Install the 10 bolts (5/16 – 18 x 1.250 LG), 10 lockwashers (5/16 ID), and 10 flat washers (5/16 ID) through the 10 holes in the passenger side of the Roof Armor Panel. Hand-tighten the bolts.

NOTE

Use shims (P/N 106796) on the mounts between the Rear Cab Armor Panel and the Roof Armor Panel Rear Bracket (P/N 106736-1) (See Figure 42).

- n. Install four bolts (3/8 – 16 x 1.500 LG) and four washers (3/8 ID) through the Rear Cab Armor Panel from inside of the cab.
- p. Place Spacer (P/N 106796-1) over the exposed threads of the four previously installed bolts (3/8 – 16 x 1.500 LG).
- r. With the Roof Armor Panel in place, remove the locknuts loosely securing the Rear Studplate (P/N 106780-2) to the Roof Armor Panel.
- s. Install the Roof Rear Bracket (P/N 106736-1) over the exposed studs of the Rear Studplate (P/N 106780-2) and over the four bolts with a shim through the Rear Cab Armor Panel (See Figure 42).

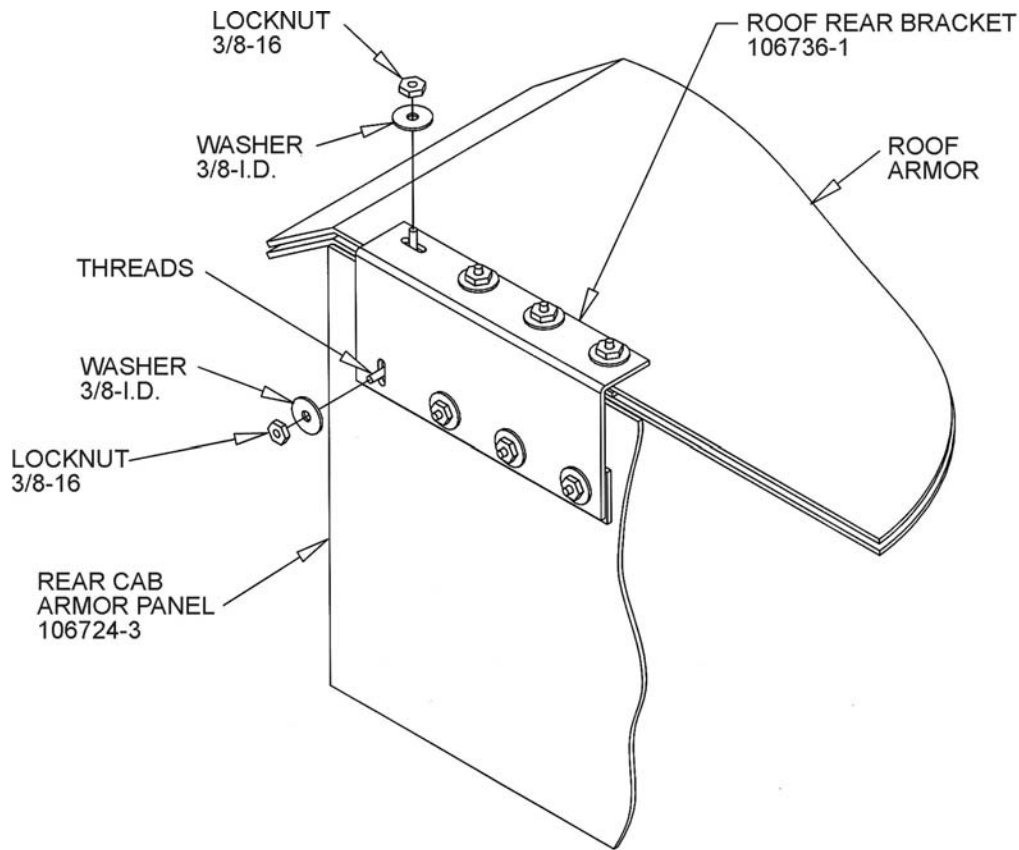

Figure 42. Position the Roof Armor Panel Rear Bracket.

- t. Install four washers (3/8 ID) and locknuts (3/8 – 16) on the top studs of the Rear Studplate (P/N 106780-2). Hand-tighten the locknuts.
- u. Install four washers (3/8 ID) and locknuts (3/8 – 16) on the rear bolts through the Rear Cab Armor Panel.
- v. Remove the locknuts loosely securing the Front Studplate (P/N 106780-1) to the Roof Armor Panel.
- w. Install the driver's-side Roof Panel Front Bracket (P/N 106735-1) over the exposed studs of the Front Studplate (P/N 106780-1) (See Figure 43).

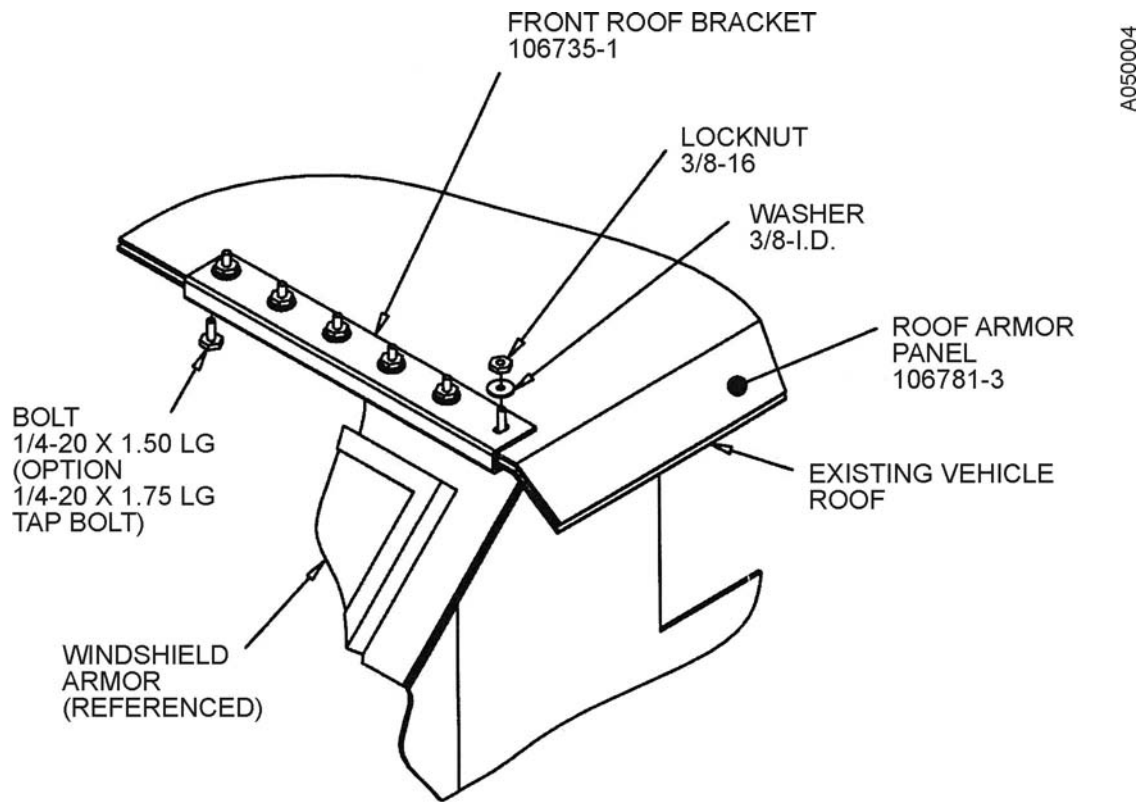
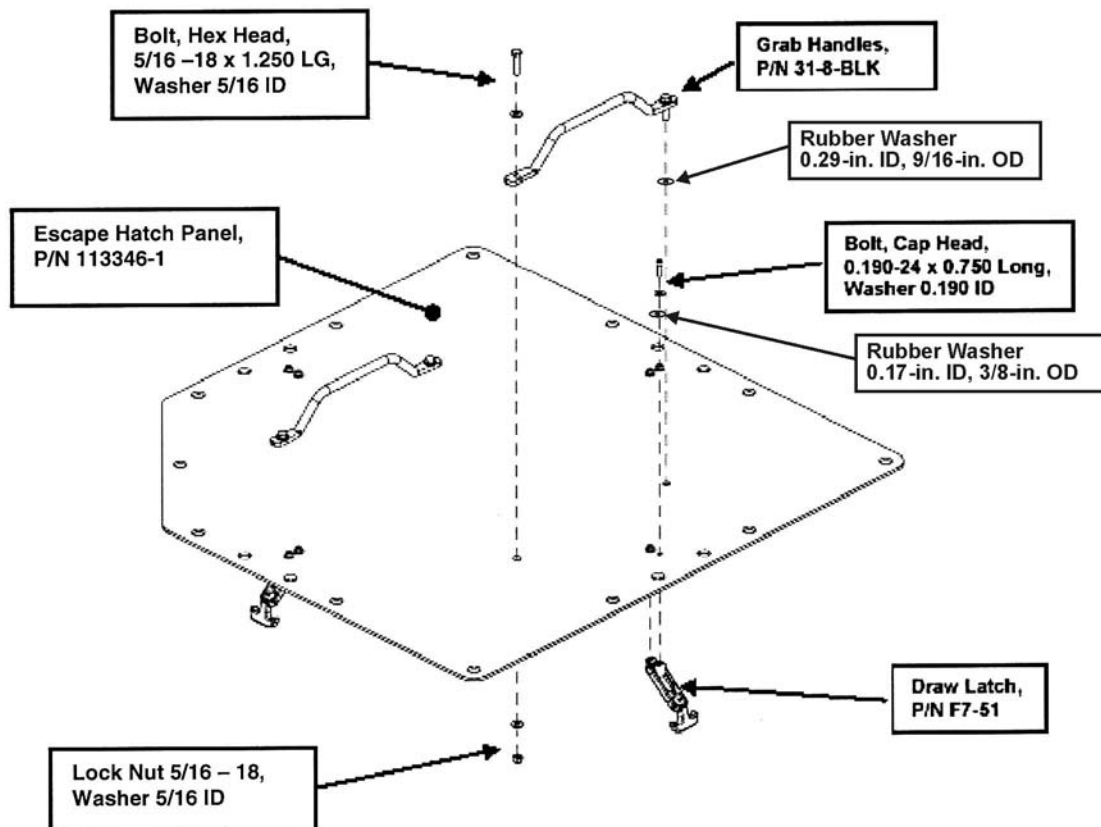

Figure 43. Secure the forward end of the Roof Armor Panel using the attachment hardware.

- x. Attach the driver's-side Roof Panel Front Bracket (P/N 106735-1) to the Studplate (P/N 106780-1) using six washers (3/8 ID) and six locknuts 3/8 – 16) (see Figure 43). Hand-tighten the locknuts.
- y. Apply Loctite 242 to five bolts (1/4 – 20 x 1.500 LG).
- z. Install the five prepared bolts (1/4 – 20 x 1.500 LG) into the bottom of the driver's-side Roof Panel Front Attachment Bracket (P/N 106735-1) (above the driver's-side windshield). Torque the bolts to 6 ft-lb.

- aa. Torque the six locknuts (3/8 – 16) on top of the driver's-side Roof Panel Front Attachment Bracket to 23 ft-lb.
- ab. Torque the four rear top locknuts (3/8 – 16) on top of the Rear Roof Panel Rear Bracket to 23 ft-lb.
- ac. Torque the four locknuts (3/8 – 16) on the bolts going through the Roof Panel Rear Bracket to 35 ft-lb.
- ad. Torque the 12 Roof Armor Panel Attachment bolts (5/16 – 18 x 1.250 and 1.750 LG) (on the passenger side) to 13 ft-lb.
- ae. Install two Handles onto the top of the Escape Hatch Panel (see Figure 44) (P/N 113346-1) using two bolts (5/16 – 18 x 1.250 LG), four metal washers (5/16 ID), four rubber washers (0.29 ID, 9/16 OD), and two nuts (5/16 – 18) for each Handle.



A050034

Figure 44. Escape Hatch Handle and Draw Latch illustration.

CAUTION

Do not over-tighten the fasteners. The fasteners may strip the threaded hole in the Draw Latch Connector if they are over-tightened.

- af. Install four Draw Latch T-Handles (P/N F7-51) onto the bottom of the Escape Hatch Panel (P/N 113346-1) using two bolts (3/16 – 24 x 0.750 LG), two metal washers (3/16 ID), and two rubber washers (0.17 ID, 3/8 OD) for each latch (see Figure 44).
- ag. Assemble four Keeper Pins (from the Draw Latch) into the four Escape Hatch Brackets (P/N 113357-1) with a bolt (3/16 – 24 x 1/4 LG) and a washer (3/16 ID) for each bracket.

CAUTION

Do not over-tighten the fasteners. The fasteners will strip the threaded hole in the Draw Latch Component if they are over-tightened.

- ah. Install the four Bracket Assemblies using the hardware shown, and in the locations shown, in Figure 45. Do not fully tighten the bolts at this time.

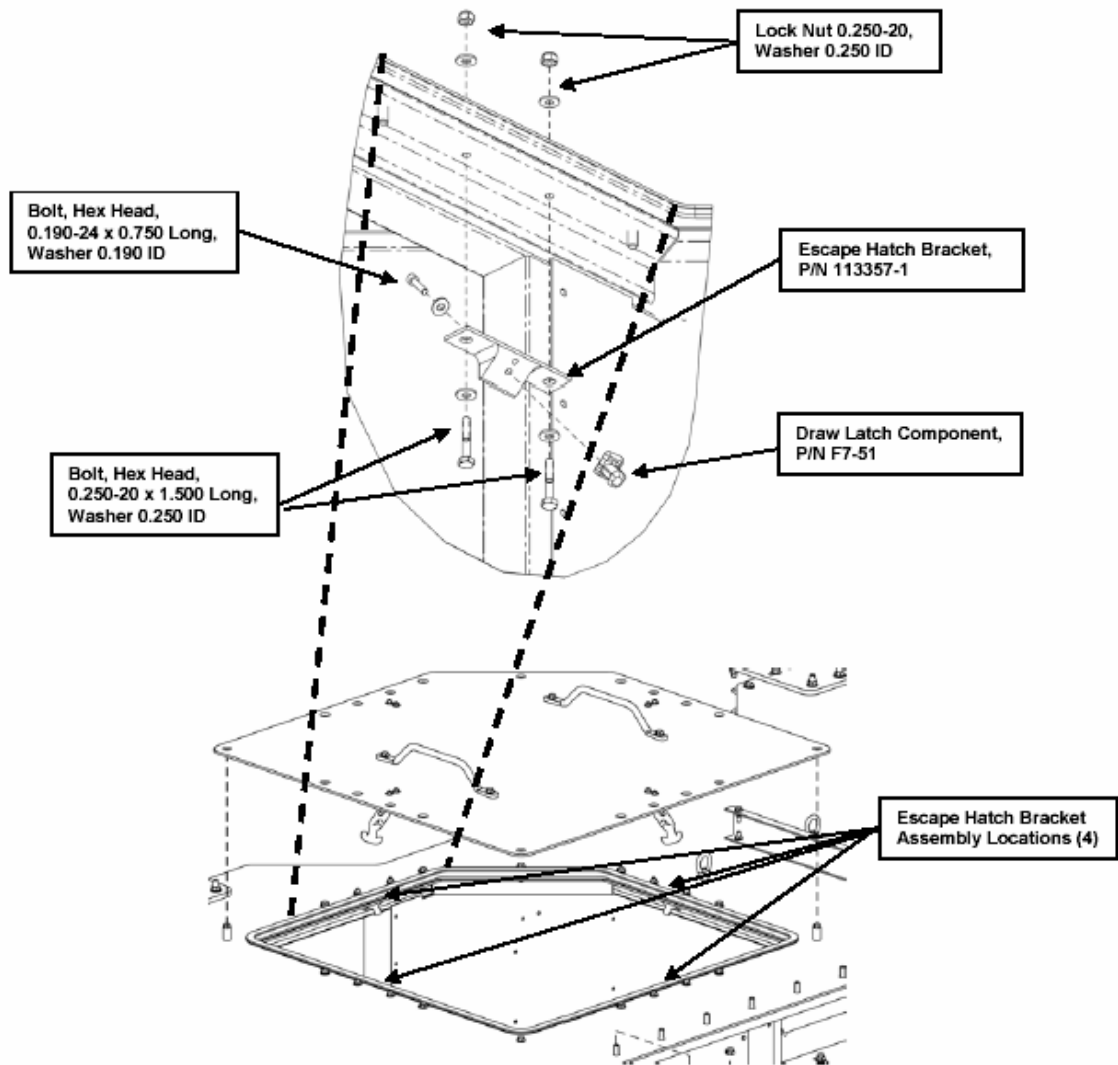

Figure 45. Installation of the Escape Hatch Brackets.

ak. Attach the four Escape Hatch Brackets (P/N 113357-1) to the top of the cab adjacent to the Escape Hatch (four sides) using two bolts (3/16 – 24 x 1/4 LG) and two washers (3/16 ID) for each bracket.

am. Install the Escape Hatch in the Roof.

an: With the hatch installed, 14 each of the 34 each hatch opening perimeter threaded holes are not used, and need to be sealed with urethane sealant (P/N 104302).

5.1.10 Re-Install the LH and RH Door-Mounted Outside Mirrors

a. Position the LH outside mirror frame and mirror on the outside of the LH door.

b. Apply Loctite 242 to four bolts (1/4 – 20 x 1.750 LG).

c. Attach the mirror frame to the door using the four prepared bolts (1/4 – 20 x 1.750 LG), four flat washers (1/4 ID), and four locknuts (1/4 – 20).

d. Torque the locknuts to 9 ft-lb.

e. Repeat Steps “a” through “d” for the RH Door-Mounted Outside Mirror.

5.1.11 Re-install the Blackout Light

a. Remove the Blackout Light from the old bracket and install it in the new bracket, (P/N 111459-1), using the same hardware (see Figure 46).

b. Extend the vehicle Blackout Light wiring connection using the Pigtail Harness, (P/N 111438-3) supplied in the Front Armor Protection Kit, P/N 106705-3.

c. Re-connect the vehicle Blackout Light wire connection using the Pigtail Harness, (P/N 111438-3)

5.1.12 Re-Install the Bridge Weight Sign

a. Re-install the Bridge Weight Sign over the holes provided on the passenger side of the Upper Brush Guard Cover (P/N 111437-1) and secure it in place using two bolts (1/4 – 20 x 1.250 LG), four flat washers (1/4 ID), and two locknuts (1/4 – 20) (See Figure 47).

b. Torque the two locknuts to 9 ft-lb.

5.1.13 Re-install the Tow Shackles

a. Position one of the tow shackles over one of the frame ends in the front of the vehicle.

b. Install the retaining pin attaching the tow shackle to the frame end.

c. Install the cotter pin in the retaining pin and spread the cotter pin ends to hold it in place.

d. Repeat Steps “a” through “c” for the remaining tow shackle.

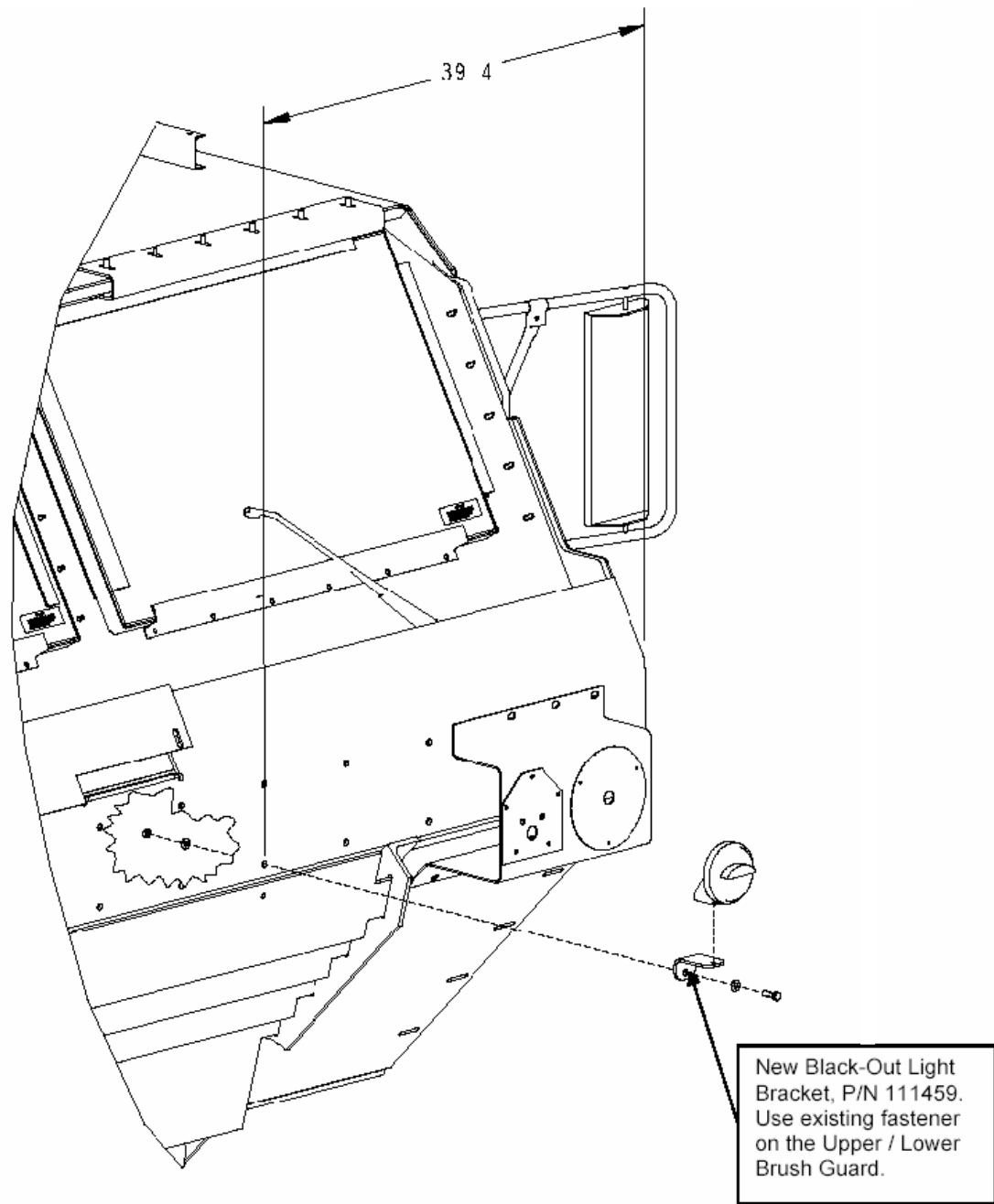

Figure 46. Blackout Light installation.

5.1.14 Re-install the Machine-Gun Mount (if required)

- a. Reverse the Upper Brush Guard Cover (bottom to top) (P/N 111437-1) to provide a notch that allows the Machine Gun Mount support bars to attach to the Brush Guard mounting structure (See Figure 47).
- b. Hoist the Machine-Gun Mount into place on the top of the cab.



Figure 47. Reversed Upper Brush Guard Cover.

- c. Replace the nuts, bolts, and washers previously removed into the mounting brackets (two in the front and one in the back).
- d. Secure the Machine-Gun Mount in place using four bolts (3/8 – 16 x 4.500), eight washers (3/8 ID), and four lock nuts (3/8 – 16). If needed, optional longer bolts (3/8 – 16 x 4.75) are included in the Extra Fastener Kit.

5.1.15 Re-install Vehicle Identification Plates

- a. Re-install the Vehicle Identification Plates from the OEM driver's door onto the new armored driver's door using the urethane sealant (P/N 104302) used for the windshield installation.

THIS PAGE INTENTIONALLY LEFT BLANK

APPENDIX A
FASTENER TORQUE VALUES

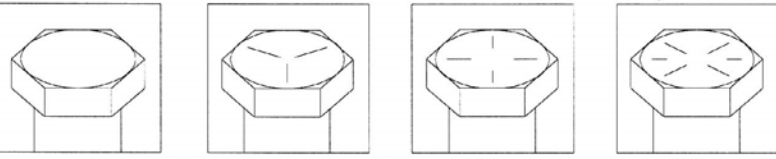
Table A-1. Torque Limits For Wet Fasteners										
CAPSCREW HEAD MARKINGS			TORQUE							
 <p>Manufacturer's marks may vary. These are all SAE Grade 5 (3-line).</p>										
SIZE			SAE GRADE NO. 2		SAE GRADE NO. 5		SAE GRADE NO. 6 OR 7		SAE GRADE NO. 8	
			POUNDS FEET	NEWTON METERS	POUNDS FEET	NEWTON METERS	POUNDS FEET	NEWTON METERS	POUNDS FEET	NEWTON METERS
DIA. IN.	THREADS PER IN.	MILLIMETERS	POUNDS FEET	NEWTON METERS	POUNDS FEET	NEWTON METERS	POUNDS FEET	NEWTON METERS	POUNDS FEET	NEWTON METERS
1/4	20	6.35	4	6	6	8	8	11	9	112
1/4	28	6.35	5	7	7	9	9	12	10	14
5/16	18	7.94	8	11	13	18	16	22	18	24
5/16	24	7.94	9	12	14	19	18	24	20	27
3/8	16	9.53	15	20	23	31	30	41	35	47
3/8	24	9.53	17	23	25	34	30	41	35	47
7/16	14	11.11	24	33	35	47	45	61	55	75
7/16	20		25	34	40	54	50	68	60	81
1/2	13	12.70	35	47	55	75	70	95	80	108
1/2	20		40	54	65	88	80	108	90	122
9/16	12	14.29	50	68	80	108	100	136	110	149
9/16	18		55	75	90	122	110	149	130	176
5/8	11	15.88	70	95	110	149	140	190	170	231
5/8	18		80	108	130	176	160	217	180	244
3/4	10	19.05	120	163	200	271	240	325	280	380
3/4	16		140	190	220	298	280	380	320	434
7/8	9	22.23	110	149	300	407	400	542	460	624
7/8	14		120	163	320	434	440	597	500	678
1	8	25.40	160	217	440	597	600	814	680	922
1	12		170	231	480	651	660	895	740	1003
1-1/8	7	25.58	220	298	600	814	840	1139	960	1320
1-1/8	12		260	353	660	895	940	1275	1080	1464
1-1/4	7	31.75	320	434	840	1139	1100	1492	1360	1844
1-1/4	12		360	488	920	1248	1320	1790	1500	2034
1-3/8	6	34.93	420	570	1100	1492	1560	2115	1780	2414
1-3/8	12		460	624	1260	1709	1780	2414	2040	2776
1-1/2	6	38.10	560	760	1460	1980	2080	2820	2360	3200
1-1/2	12		620	841	1640	2224	2320	3146	2660	3607

Note: AVK Rivnuts and PEM studs are torqued to the Grade 5 values listed on the chart.
 Surface-resistance-welded studs are torqued to Grade 2 values listed on the chart.
 No. 10 bolts are torqued to 25 in.-lb.

DO NOT EXCEED THE LISTED TORQUE VALUES.

**EQUIPMENT INSTALLATION INSTRUCTIONS AND PARTS LIST
FOR THE
HEAVY EXPANDED MOBILITY TACTICAL TRUCK (HEMTT)
COMMAND, CONTROL, COMMUNICATIONS, COMPUTERS, INTELLIGENCE,
SURVEILLANCE, AND RECONNAISSANCE (C4ISR)
MOUNTING HARDWARE KIT**





Contract No. W56HZV-04-C-0259

Prepared for:

U.S. Army Tank – Automotive Command (TACOM)
AMSTA-AQ-ATBC
Warren, MI 48397-5000

Prepared by:

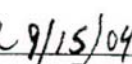
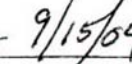
Simula Aerospace and Defense Group, Inc.
7822 South 46th Street
Phoenix, AZ 85044-5354
(602) 643-7233

Prepared by:  George Sprague ILS / R&M Engineer	Approved by:  Quentin Jacobson Product Development Engineer	Approved by:  Curt Parsons Manager, Armor Systems
 Date	 Date	 Date

THIS PAGE INTENTIONALLY LEFT BLANK

REVISIONS				
REV	CHANGED BY	DESCRIPTION	CM RELEASE	DATE
-		Initial Release Per ECO 485755	/s/ K. Rodriguez	21-Sep-04
A	G. Sprague	Revised Per ECO 486258	/s/ J. Celis	22-Nov-04

THIS PAGE INTENTIONALLY LEFT BLANK

TABLE OF CONTENTS

1. INTRODUCTION	1
1.1 GENERAL.....	1
1.2 WARNINGS, CAUTIONS, AND NOTES	1
2. HEMTT C4ISR MOUNTING HARDWARE KIT INSTALLATION	2
2.1 EQUIPMENT AND MATERIALS	2
2.2 GENERAL INSTALLATION INSTRUCTIONS.....	2
2.3 PERSONNEL SKILL LEVEL	2
2.4 PARTS LIST	3
3. C4ISR MOUNTING HARDWARE KIT ASSEMBLY PROCEDURES.....	6
3.1 INSTALL MTS BRACKET PLATE ASSEMBLY, P/N 111449-1	6
3.2 INSTALL PLGR ANTENNAE MOUNTING BRACKET, P/N 111452	6
3.3 MOUNTING THE PLGR ANTENNAE	6
3.4 SECURING THE “P” CLAMPS FOR THE ANTENNA WIRES	6

LIST OF ACRONYMS AND ABBREVIATIONS

C4ISR	Command, Control, Communications, Computers, Intelligence, Surveillance, and Reconnaissance
ft-lb	foot-pounds
HEMTT	Heavy Expanded Mobility Tactical Truck
in.	inch
mm	millimeter
MIL-SPEC	Military Specification
MTS	Movement Tracking System
P/N	Part Number
PLGR	Precision Lightweight GPS Receiver

1. INTRODUCTION

1.1 GENERAL

This document provides the Installation Instructions for the C4ISR Mounting Hardware Kit, P/N 111450-1 (the Kit), which is manufactured by Simula Aerospace and Defense Group, Inc., (Simula) for the HEMTT. This Kit is composed of a Precision Lightweight GPS Receiver (PLGR) Antenna Mounting Bracket, a Movement Tracking System (MTS) Mounting Bracket, and mounting hardware, and is required for use with the HEMTT Crew Protection Armor Kit, P/N 106700-5.

1.2 WARNINGS, CAUTIONS, AND NOTES

Warnings, Cautions, and Notes are included in these Installation Instructions to provide short, concise statements that emphasize critical or important information. Warnings, Cautions, and Notes precede the text that they affect, but follow the paragraph headings to which they apply. Warnings precede Cautions, and Cautions, in turn, precede Notes. A format example and an explanation of the function of each are provided below.

WARNING

WARNINGS HIGHLIGHT AN OPERATING OR MAINTENANCE PROCEDURE, PRACTICE, CONDITION, STATEMENT, ETC., WHICH, IF NOT STRICTLY OBSERVED, COULD RESULT IN INJURY TO PERSONNEL OR LOSS OF LIFE.

CAUTION

Cautions highlight an operating or maintenance procedure, practice, condition, statement, etc., which, if not strictly observed, could result in damage to, or destruction of, equipment, loss of mission effectiveness, or long-term health hazards to personnel.

NOTE

Notes highlight an essential operating or maintenance procedure, condition, or statement.

2. HEMTT C4ISR MOUNTING HARDWARE KIT INSTALLATION

2.1 EQUIPMENT AND MATERIALS

The equipment and materials required to install the C4ISR Mounting Hardware Kit onto the HEMTT are provided in Table 1.

Description	Part Number
Automotive General Mechanics Tool Kit	SC5180-90-N26
1/2-in. Drill	Commercially Available
9/32-in. Drill Bit	Commercially Available
Ball Peen Hammer	Commercially Available
Cold Chisel	Commercially Available

2.2 GENERAL INSTALLATION INSTRUCTIONS

NOTE

These Installation Instructions will provide the illustration directly after that installation callout, and the text will be on either the same page or the facing page, where practical. All necessary information, torque values, tool numbers, and materials used will be provided so that the unit can be assembled without reference to another part of the installation instructions.

- a. Before beginning the assembly of a part, remove all corrosion-preventative compound (if any) and any accumulated foreign matter.
- b. All nuts, bolts, and screws used in the installation of the Kit must be coated with Loctite 242 thread lock adhesive and tightened to standard torque values, unless otherwise stated. The locknuts supplied with the Kits do not require Loctite 242. A list of standard thread / pitch sizes and the corresponding torque values are provided in Appendix A.
- c. Inspect the Rear Cab Armor Panels, P/N 106724-3 / -4 for welded studs. If the Panels contain welded studs, perform the following procedure:
 1. Remove all of the welded studs from the Rear Cab Armor Panels, P/N 106724-3 / -4.
 2. Suggested stud removal process: Use a ball peen hammer and medium-sized cold chisel. Align the chisel's edge against the base of the stud where the stud adheres to the Armor Panel. Dislodge the stud using repeated hammer blows on the chisel until the stud is freed from the Armor Panel. If one is available, an air chisel may be used to remove the studs.
 3. Prime / paint any exposed bare metal after the stud is removed.

2.3 PERSONNEL SKILL LEVEL

The installation skill level required to complete the installation of the Kit shall be MOS 63S, Heavy Wheel Vehicle Mechanic.

2.4 PARTS LIST

The C4ISR Mounting Hardware Kit, P/N 111450-1, is composed of 10 items as follows:

Item No.	Name	Part Number	Quantity
1	Plate Assembly, MTS Bracket	111449-1	1
2	Bracket, PLGR Antenna Mount	111452-1	1
3	Bolt, Hex Head, Grade 8, 0.250 – 28 x 1.000	-	2
4	Nut, Self-Locking, Grade C, 0.250 – 20	-	9
5	Nut, Self-Locking, 10 - 24	-	8
6	Washer, Grade 8, 0.250 ID	-	11
7	Washer, Grade 8, No. 10	-	8
8	Installation Instructions, C4ISR Mounting Hardware Kit	II11450-1	1
9	Nut, 0.250 - 28	-	2
10	Bolt, Hex Head, Grade 8, 0.25 – 20 x 0.750	-	2

The Rear Cab Armor Panel, P/N 106724-4, is shown in Figure 2.1. A “P” clamp is used to route cables to the PLGR antenna, and one of the 0.250-in.-diameter studs that are used to secure the P/N 106724-4 Armor Panel to the vehicle should be used to secure the “P” clamp.

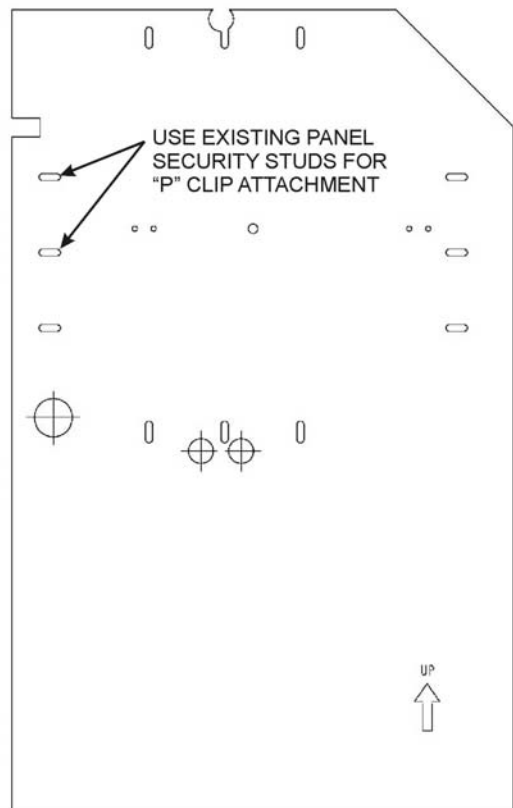

Figure 2.1. Right Rear Cab Armor Panel 106724-4 (Passenger Side).

If none exist, it may be necessary to drill holes in the Roof Support Bracket to be used for the attachment of the "P" clamps. A new bracket with four pressed-in studs is used to hold the connector guard. The bracket is secured to the Armor Panel, P/N 106724-3, using studs that are also used to secure the Armor Panel to the vehicle cab.

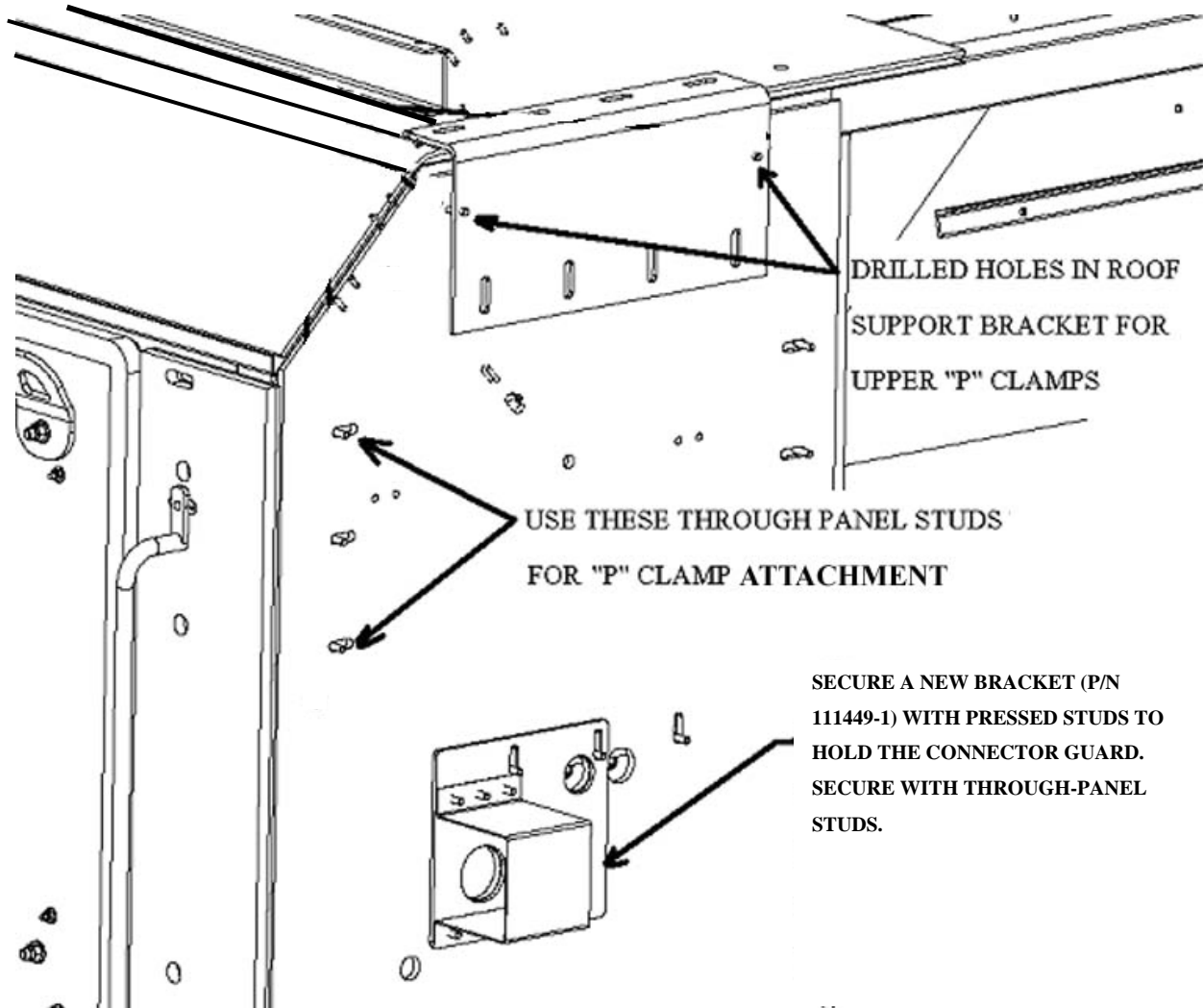
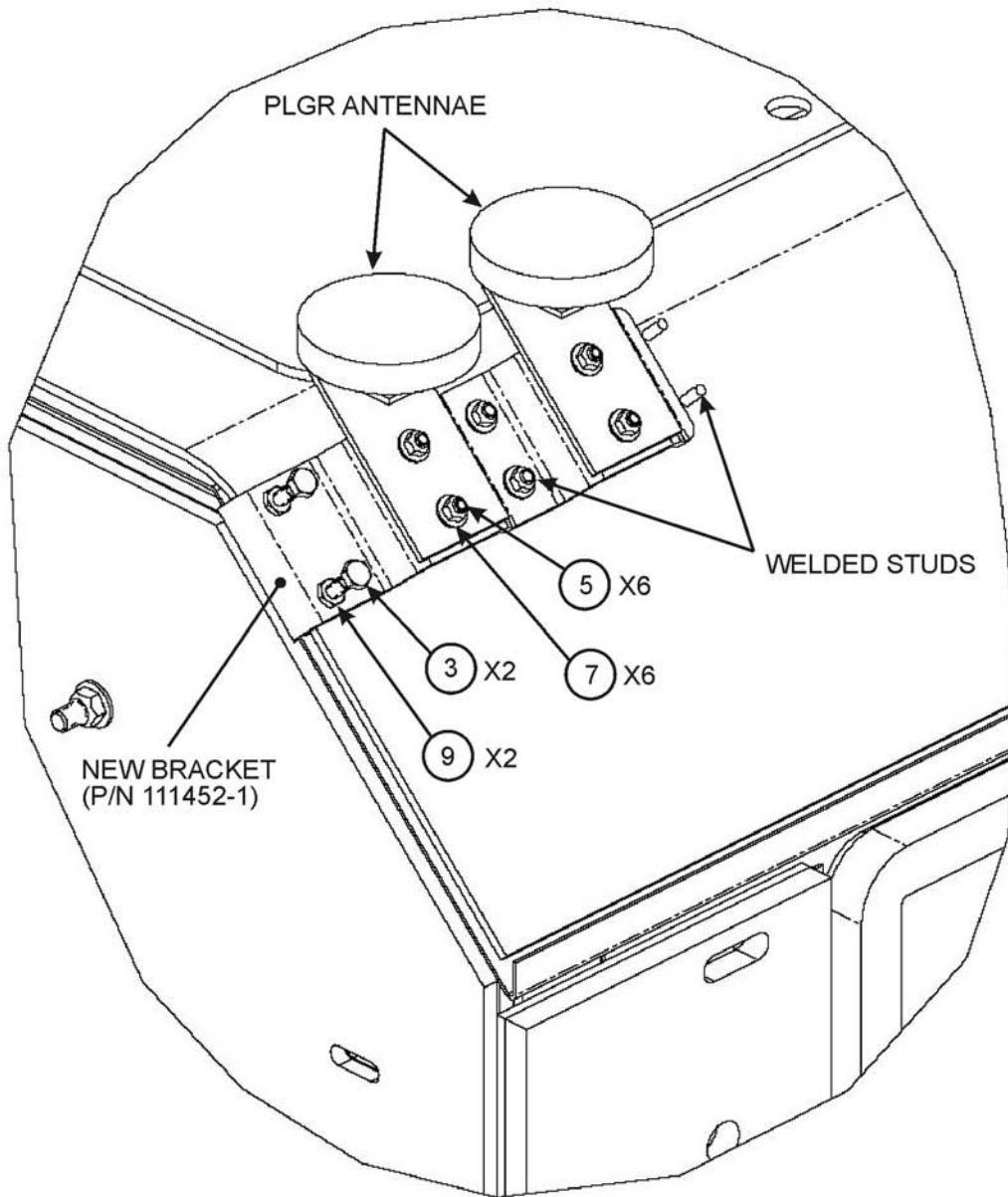

Figure 2.2. Left Rear Cab Armor Panel 106724-3 (Driver's side).

Secure the PLGR antennae to the vehicle with a clamp-on bracket, P/N 111452-1, as shown in Figure 2.3.



A040048

Figure 2.3. PLGR Antennae mount.

3. C4ISR MOUNTING HARDWARE KIT ASSEMBLY PROCEDURES

WARNING

**THE EDGES OF THE METAL ARMOR PANELS MAY BE SHARP.
PROTECTIVE GLOVES SHOULD BE WORN BY THE INSTALLATION TEAM
TO PREVENT PERSONAL INJURY.**

3.1 INSTALL MTS BRACKET PLATE ASSEMBLY, P/N 111449-1

Install the MTS Bracket Plate Assembly, P/N 111449-1, onto the two through-panel studs on the Armor Panel using one Washer, 0.250-in. ID, and one Locknut, 0.250 – 20, on each of the through-panel studs (See Figure 2.2).

3.2 INSTALL PLGR ANTENNAE MOUNTING BRACKET, P/N 111452

Install the PLGR Antennae Mounting Bracket by clamping it onto the Roof Armor Panel (See Figure 2.3). The clamp is secured to the Roof Armor Panel using two Bolts, 0.250 x 28 – 1.000, and two Jam Nuts, 0.250 – 28. Torque to 6 ft-lb each. Redundant fastening may be achieved by using the two center studs that are welded to the roof; however, it is not essential that these studs be used. The two center studs protruding through the Bracket are secured with one Washer, No. 10, and one Locknut, 10 - 24, each.

3.3 MOUNTING THE PLGR ANTENNAE

The PLGR Antennae are secured to the Mounting Bracket stud (See Figure 2.3) using two Washers, No. 10, and two Locknuts, 10 – 24, for each antenna.

3.4 SECURING THE “P” CLAMPS FOR THE ANTENNA WIRES

Two holes must be drilled in the Roof Support Bracket (See Figure 3.2) if the Bracket is not received pre-drilled. A 9/23-in. drill bit is used to drill the two holes with the Support Bracket in place. The “P” Clamps can then be attached to the Roof Support Bracket as indicated in Figure 2.1 and 2.2 using the existing hardware.

A040044

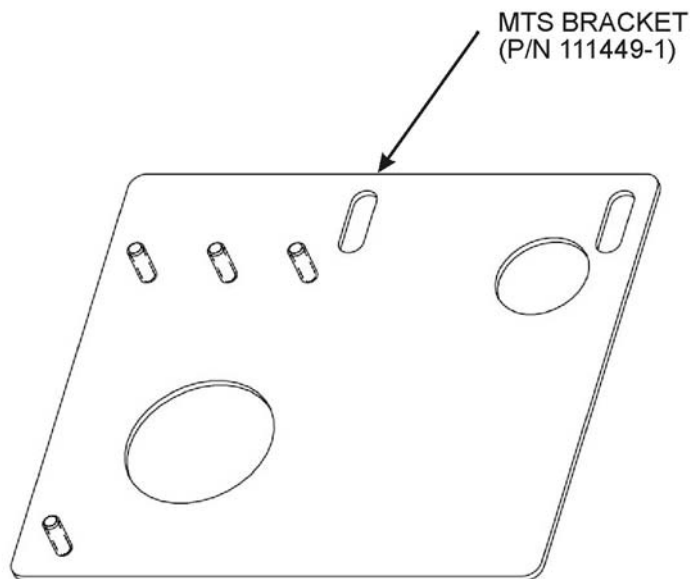
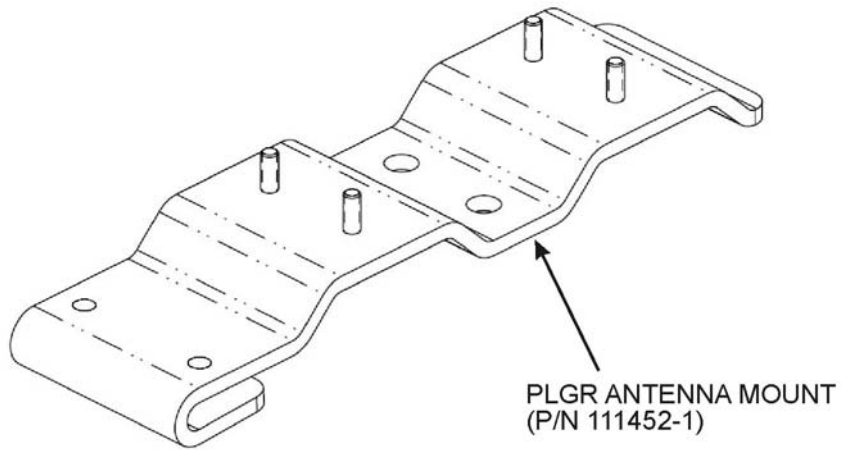

Figure 3.1. Mounting Brackets.

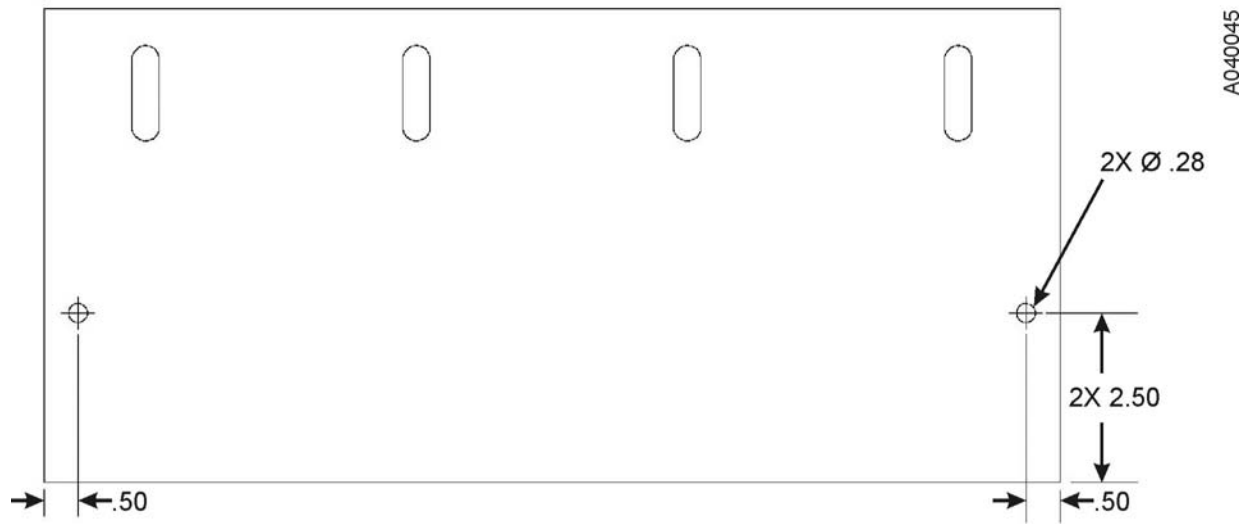

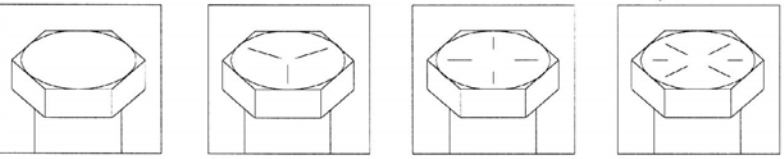

Figure 3.2. Roof Support Bracket hole locations.

APPENDIX A

FASTENER TORQUE VALUES

Table A-1. Torque Limits For Wet Fasteners										
CAPSCREW HEAD MARKINGS										
 <p>Manufacturer's marks may vary. These are all SAE Grade 5 (3-line).</p>										
SIZE			TORQUE							
			SAE GRADE NO. 2		SAE GRADE NO. 5		SAE GRADE NO. 6 OR 7		SAE GRADE NO. 8	
DIA. IN.	THREADS PER IN.	MILLIMETERS	POUNDS FEET	NEWTON METERS	POUNDS FEET	NEWTON METERS	POUNDS FEET	NEWTON METERS	POUNDS FEET	NEWTON METERS
1/4	20	6.35	4	6	6	8	8	11	9	112
1/4	28	6.35	5	7	7	9	9	12	10	14
5/16	18	7.94	8	11	13	18	16	22	18	24
5/16	24	7.94	9	12	14	19	18	24	20	27
3/8	16	9.53	15	20	23	31	30	41	35	47
3/8	24	9.53	17	23	25	34	30	41	35	47
7/16	14	11.11	24	33	35	47	45	61	55	75
7/16	20		25	34	40	54	50	68	60	81
1/2	13	12.70	35	47	55	75	70	95	80	108
1/2	20		40	54	65	88	80	108	90	122
9/16	12	14.29	50	68	80	108	100	136	110	149
9/16	18		55	75	90	122	110	149	130	176
5/8	11	15.88	70	95	110	149	140	190	170	231
5/8	18		80	108	130	176	160	217	180	244
3/4	10	19.05	120	163	200	271	240	325	280	380
3/4	16		140	190	220	298	280	380	320	434
7/8	9	22.23	110	149	300	407	400	542	460	624
7/8	14		120	163	320	434	440	597	500	678
1	8	25.40	160	217	440	597	600	814	680	922
1	12		170	231	480	651	660	895	740	1003
1-1/8	7	25.58	220	298	600	814	840	1139	960	1320
1-1/8	12		260	353	660	895	940	1275	1080	1464
1-1/4	7	31.75	320	434	840	1139	1100	1492	1360	1844
1-1/4	12		360	488	920	1248	1320	1790	1500	2034
1-3/8	6	34.93	420	570	1100	1492	1560	2115	1780	2414
1-3/8	12		460	624	1260	1709	1780	2414	2040	2776
1-1/2	6	38.10	560	760	1460	1980	2080	2820	2360	3200
1-1/2	12		620	841	1640	2224	2320	3146	2660	3607

NOTE: Use Grade 2 torque values for all PEM Studs, welded studs, and AVK Rivnuts unless otherwise noted in the instructions. For #10 fasteners, do not exceed 2 ft-lb of force.

THIS PAGE INTENTIONALLY LEFT BLANK

INDEX

<i>Subject</i>	<i>Work Package/Page</i>
A	
Abbreviations/Acronyms, List of	0001 00-2
Adjustment, Door Latch	0016 00-1
B	
Ballistic Glass and Frame Assembly Replacement, Door	0014 00-1
Ballistic Glass Replacement	
Door	0014 00-1
Door, Model B	0014 01-1
Windshield	0017 00-1
Ballistic Glass Replacement, Model B, Door	0014 01-1
Ballistic Glass, Cleaning	0010 00-1
Blackout Drive Light Replacement	0022 00-1
Blast Deflector Replacement	
Center	0029 00-1
Left Side	0028 00-1
Right Side	0027 00-1
Brush Guard Replacement	
Lower	0019 00-1
Upper	0018 00-1
C	
Characteristics, Capabilities, and Features, Equipment	0002 00-1
Cleaning Ballistic Glass	0010 00-1
Composite Light Replacement	0021 00-1
Corrosion Prevention and Control (CPC)	0001 00-1
D	
Data, Equipment	0002 00-4
Decals	0007 00-1
Description and Use of Operator Controls	0004 00-1
Destruction of Army Materiel to Prevent Enemy Use	0001 00-1
Door	
Assembly Replacement	0015 00-1
Assembly Replacement, Model B	0015 01-1
Ballistic Glass and Frame Assembly Replacement	0014 00-1
Ballistic Glass Replacement, Model B	0014 01-1
Handle Assembly Replacement	0012 00-1
Handle Assembly Replacement, Model B	0012 01-1
Latch Adjustment	0016 00-1

INDEX - Continued

Subject *Work Package/Page*

D - Continued

Latch Adjustment, Model B	0016 01-1
Latch and Combat Lock Replacement, Model B	0013 01-1
Latch and Lock Pin Replacement	0013 00-1

E

Equipment	
Characteristics, Capabilities, and Features	0002 00-1
Data	0002 00-4
Equipment Data, Model B	0002 00-5
Equipment Improvement Recommendations (EIRs), Reporting	0001 00-1
Escape Hatch Assembly Maintenance	0023 00-1
Expendable and Durable Items List	0035 00-1

G

Gen IIIB Installation Instructions	0039 01-1
General Maintenance Instructions	0011 00-1
Grille Replacement, Louvered	0020 00-1

H

Handle Assembly Replacement, Door	0012 00-1
Handle Assembly Replacement, Model B, Door	0012 01-1
Hatch Assembly Maintenance, Escape	0023 00-1
Headlight Replacement	0021 00-1

I

Initial Adjustments and Daily Checks	0005 00-1
--	-----------

L

Latch Adjustment	
Door	0016 00-1
Door, Model B	0016 01-1
Latch and Combat Lock Replacement, Model B, Door	0013 01-1
Latch and Lockpin Replacement, Door	0013 00-1
List	
Abbreviations/Acronyms	0001 00-2
Expendable and Durable Items	0035 00-1
Location and Description of Major Components	0002 00-2
Location and Description of Major Components, Model B	0002 00-3
Louvered Grille Replacement	0020 00-1
Lower Brush Guard Replacement	0019 00-1

INDEX - Continued

<i>Subject</i>	<i>Work Package/Page</i>
M	
Maintenance Allocation Chart (MAC)	
Introduction	0033 00-1
Tables	0034 00-1
Maintenance Forms, Records, and Reports	0001 00-1
Major Components, Location and Description of	0002 00-2
O	
Operating HEMTT	0005 00-1
Operation	
Under Unusual Conditions	0006 00-1
Under Usual Conditions	0005 00-1
Operator Controls	0004 00-1
Operator Controls, Model B	0004 00-3
P	
Preparation for Storage or Shipment	0001 00-1
Preventive Maintenance Checks and Services (PMCS)	
Introduction	0008 00-1
Table	0009 00-1
Q	
Quality of Material	0001 00-2
R	
Rear Cab Armor Replacement	
Left	0026 00-1
Right	0025 00-1
References	0032 00-1
Reporting Equipment Improvement Recommendations (EIRs)	0001 00-1
Roof Armor Replacement	0024 00-1
S	
Safety, Care, and Handling	0001 00-2
Side Armor Replacement	
Front Assembly	0031 00-1
Model B	0031 01-1
Rear	0030 00-1
Storage or Shipment, Preparation for	0001 00-1
Stowage and Data Plates	0007 00-1

INDEX - Continued

<i>Subject</i>		<i>Work Package/Page</i>
	T	
Theory of Operation		0003 00-1
	U	
Upper Brush Guard Replacement		0018 00-1
	W	
Warning Summary		a
Windshield Ballistic Glass Replacement		0017 00-1

By Order of the Secretary of the Army:

PETER J. SCHOOMAKER
General, United States Army
Chief of Staff

Official:

SANDRA R. RILEY
Administrative Assistant to the
Secretary of the Army
0520306

DISTRIBUTION: To be distributed in accordance with the initial distribution requirements for IDN: 344822, requirements for TB 9-2320-279-13&P-2.

THE METRIC SYSTEM AND EQUIVALENTS

<p>Linear Measure</p> <p>1 Centimeter = 10 Millimeters = 0.01 Meters = 0.3937 Inches 1 Meter = 100 Centimeters = 1000 Millimeters = 39.37 Inches 1 Kilometer = 1000 Meters = 0.621 Miles</p> <p>Weights</p> <p>1 Gram = 0.001 Kilograms = 1000 Milligrams = 0.035 Ounces 1 Kilogram = 1000 Grams = 2.2 Pounds 1 Metric Ton = 1000 Kilograms = 1 Megagram = 1.1 Short Tons</p> <p>Liquid Measure</p> <p>1 Milliliter = 0.001 Liters = 0.0338 Fluid Ounces 1 Liter = 1000 Milliliters = 33.82 Fluid Ounces</p>	<p>Square Measure</p> <p>1 Sq Centimeter = 100 Sq Millimeters = 0.155 Sq Inches 1 Sq Meter = 10,000 Sq Centimeters = 10.76 Sq Feet 1 Sq Kilometer = 1,000,000 Sq Meters = 0.386 Sq Miles</p> <p>Cubic Measure</p> <p>1 Cu Centimeter = 1,000 Cu Millimeters = 0.06 Cu Inches 1 Cu Meter = 1,000,000 Cu Centimeters = 35.31 Cu Feet</p> <p>Temperature</p> <p>$5/9 (^{\circ}\text{F} - 32) = ^{\circ}\text{C}$ 212° Fahrenheit is equivalent to 100° Celsius 90° Fahrenheit is equivalent to 32.2° Celsius 32° Fahrenheit is equivalent to 0° Celsius $9/5 \text{ C}^{\circ} + 32 = \text{F}^{\circ}$</p>
--	--

APPROXIMATE CONVERSION FACTORS

To Change	To	Multiply By
Inches	Centimeters	2.540
Feet	Meters	0.305
Yards	Meters	0.914
Miles	Kilometers	1.609
Sq Inches	Sq Centimeters	6.451
Sq Feet	Sq Meters	0.093
Sq Yards	Sq Meters	0.836
Sq Miles	Sq Kilometers	2.590
Acres	Sq Hectometers	0.405
Cubic Feet	Cubic Meters	0.028
Cubic Yards	Cubic Meters	0.765
Fluid Ounces	Milliliters	29.573
Pints	Liters	0.473
Quarts	Liters	0.946
Gallons	Liters	3.785
Ounces	Grams	28.349
Pounds	Kilograms	0.454
Short Tons	Metric Tons	0.907
Pound-Feet	Newton-Meters	1.356
Pounds per Sq Inch	Kilopascals	6.895
Miles per Gallon	Kilometers per Liter	0.425
Miles per Hour	Kilometers per Hour	1.609

To Change	To	Multiply By
Centimeters	Inches	0.394
Meters	Feet	3.280
Meters	Yards	1.094
Kilometers	Miles	0.621
Sq Centimeters	Sq Inches	0.155
Sq Meters	Sq Feet	10.764
Sq Meters	Sq Yards	1.196
Sq Kilometers	Sq Miles	0.386
Sq Hectometers	Acres	2.471
Cubic Meters	Cubic Feet	35.315
Cubic Meters	Cubic Yards	1.308
Milliliters	Fluid Ounces	0.034
Liters	Pints	2.113
Liters	Quarts	1.057
Liters	Gallons	0.264
Grams	Ounces	0.035
Kilograms	Pounds	2.205
Metric Tons	Short Tons	1.102
Newton-Meters	Pound-Feet	0.738
Kilopascals	Pounds per Sq Inch	0.145
Kilometers per Liter	Miles per Gallon	2.354
Kilometers per Hour	Miles per Hour	0.621

